

PERMACON

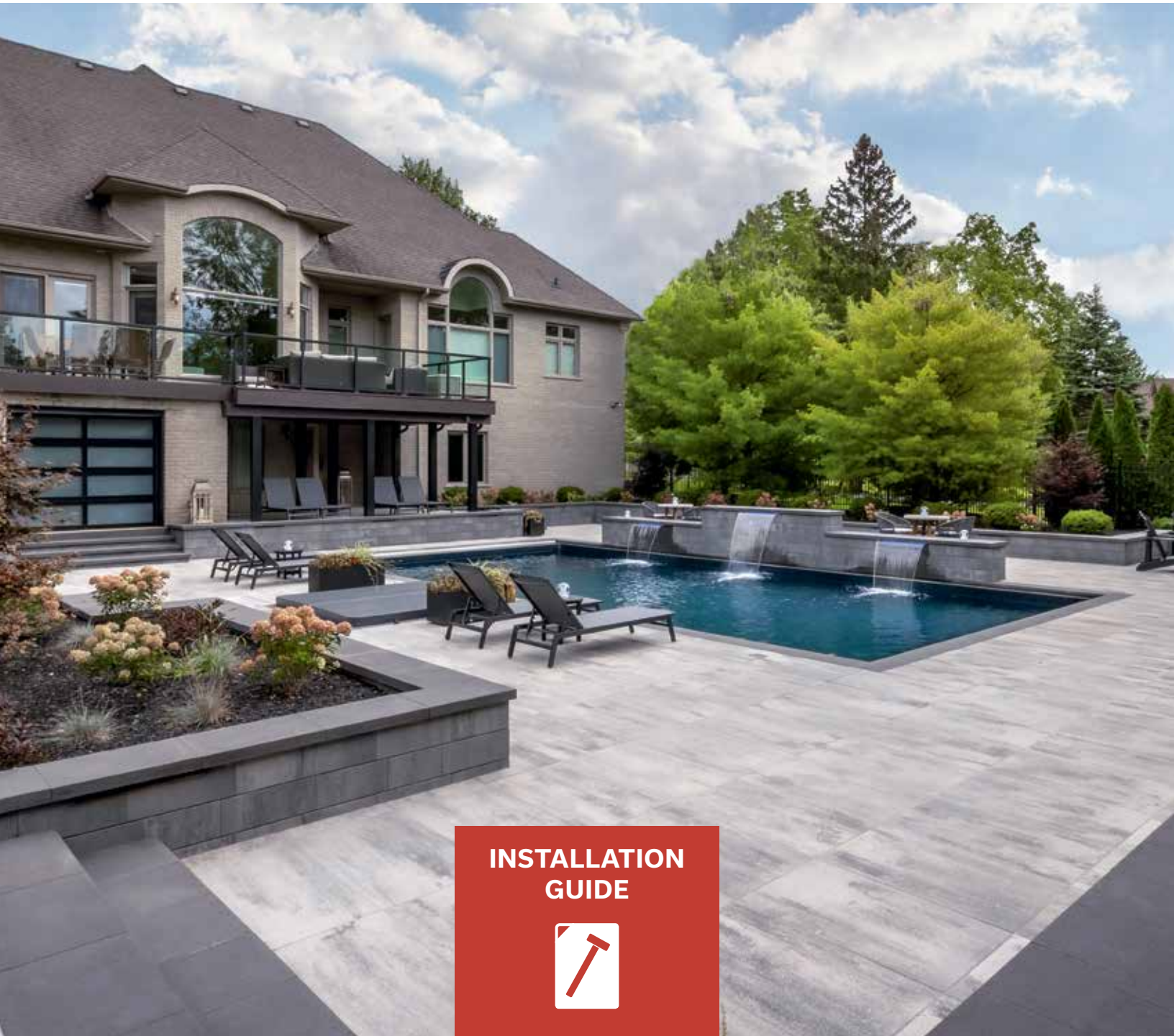

INSTALLATION
GUIDE



Landscape Products

Table of Contents

Pavers		Curbs and Accessories	
Generic Installation	3	Curbs and Accessories Index	282
Typical Cross-Section	6	Typical Installation	283
Paver Index	7	Celtik Curb	284
Ecological Pavers: Cassara Verde, Turfstone Paver, Virage and Zen	8	Pool Capping	285
Virage Paver	13	Overlay of Steps with Mondrian Plus Capping	286
Residential Permeable Pavers	26	Steps	287
Architectural Pavers: Agora Aqua and Agora	30	Mirage Porcelain Tiles	291
Slabs		Alternative Landscaping	
Generic Installation	33	Artex Panel System	294
Typical Cross-Section	36	Orion Firepit	322
Slab Index	37	Complementary Products	
Rosebel Slab	38	Polymeric Sand	328
Wilfrid Slab	40	Sand Quantity Chart for Pavers and Slabs	328
Walls		Sand Quantity Chart for Architectural Pavers and Slabs	329
Generic Installation	42	<hr/>	
Typical Cross-Section	45	Warranty	331
Table of Wall Characteristics	46		
Wall Index	47		
Tandem Next System Wall	48		
Tandem System Wall	68		
- Building a Double-Sided Wall	79		
- Building Stairs	89		
- Building Pillars	92		
- Outdoor Living Components	102		
Celtik Plus 90 Wall	131		
Grande Wall	136		
Orion Wall	185		
RB Wall	191		
Universal Slope Block Wall	193		
Urbano Wall	194		
Vario Wall	210		
Wallstone and Wedgestone Walls	266		
Wall Installation Guidelines	270		
Keystone Wall	272		

The information contained in these technical documents is supplied for information purposes only. Any application of the information is the sole responsibility of the installer. The installer must ensure that the installation and use of retaining wall or permeable installation projects comply with local regulations and code requirements. A qualified engineer must be consulted for final design for construction purposes. Oldcastle Building Products Canada, Inc. and its affiliates cannot be held responsible for the improper use of information contained in these technical documents.

Pavers

PAVER INSTALLATION (GENERIC)

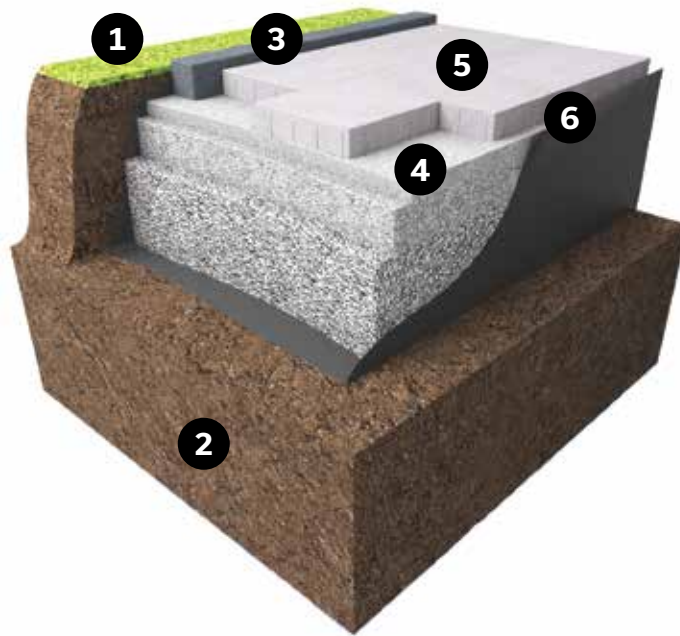

TOOLS REQUIRED

- > 1 wheelbarrow
- > A few pegs
- > 2 rigid pipes with a diameter of 25 mm - 1 in x 3 m - 10 ft
- > 1 plank: 25 mm x 150 mm x 2.4 m - 1 in x 6 in x 8 ft.
- > 1 plumb line
- > 1 level
- > 1 bricklayer's line: 15 m long - 50 ft
- > 1 shovel
- > 1 chalk line
- > 1 measuring tape
- > 1 broom
- > 1 rake
- > 1 guillotine or concrete saw (available from rental stores)
- > 1 vibrating plate (compacting tool available from tool rental stores)

OPTIONAL TOOLS

- > Jumping jack
- The jumping jack should not be used to compact pavers. It should only be used for the foundation.

1 EXCAVATION

If pipes or wires are located in the area to be excavated, contact the representatives of the company concerned before the work is started.

To ensure adequate drainage, excavate the soil to obtain a minimum 2% slope (20 mm per metre or 1/4 inch per foot). The slope can be reduced to 1% if the drainage of all the landscaping is well controlled. In case of doubt, obtain an expert's assistance for a detailed analysis of everything concerning drainage (slopes of the ground, soil type, landscaping, etc.).

The excavation contour should extend beyond the surface to be paved by at least 300 mm - 12 in. Ideally, this distance should be 1 to 1 1/2 times the thickness of the foundation. The stability of the project depends on this measurement, which ensures that the paving stones at the edge will be as well supported as those in the centre.

Level the bottom of the excavation with a rake and if the soil is sandy, compact it with a vibrating plate or roller. It is preferable not to pack clay soil at this stage. In this case, the use of a geotextile membrane placed between the natural soil and the foundation is recommended to prevent foundation contamination by clay and ensure greater stability. Refer to the chart EXCAVATION DEPTH AND MINIMUM FOUNDATION to get the minimum excavation required (ref: photo #1).

2 FOUNDATION

Spread and compact the 0 to 20 mm - 0 to 3/4 in. stone in 100 mm - 4 in. layers. Lightly water the 0 to 20 mm - 0 to 3/4 in. stone to make tamping easier. To ensure an adequate foundation, compact the stone several times with a vibrating plate, roller, or a jumping jack (ref: photo #2). Once this stage is completed, you will be able to see what the final result will look like. You can verify the final level of the pavers by placing a paver on a guide (ref: photo #3). Refer to the typical installation drawings (see page 6).

3 CURB

If you install a Nova curb type, proceed with installation of the curbs immediately before completing the foundation. Start by laying the first side of the curb. Before installing the other side of the curb, temporarily place a row of pavers on the ground to determine the ideal distance and the position of the other curb, and thus minimize the size of the pavers. If you install a Melville curb, a Lafitt curb, a Celtik curb or even a plastic curb, refer to LAYING PAVERS.

4 INSTALLATION BED

Spread between 15 mm - 5/8 in. and 25 mm - 1 in. of concrete sand or screening (ref: photo #4). Bear in mind that a 25 mm - 1 in. bed will be reduced down to 15 mm - 5/8 in. in thickness once compacting is completed and after the paving stones are installed.

Level the concrete sand using two (2) 25 mm - 1 in. diameter pipes and a straight plank (ref: photo #5). Any significant variation in bed thickness may cause irregularities in the paved surface.

Make sure you do not compact the screenings or the sand before laying the pavers on the installation bed. Fill the holes left by the pipes.

5 LAYING THE PAVERS

Arrange the paving stones according to the pattern chosen with a 90° angle if possible. Proceed by walking on the paving stones (ref: photo #6).

Paving stones are manufactured with side spacers that will set a space of 3 mm - 1/8 in. between each paver. A space of 2 mm must be allowed for paving stones without spacers.

To obtain an even distribution of colour and texture, it is recommended that you choose paving stones from more than one cube at a time. Moreover, working across each cube always gives the best results.

Check the alignment of the pavers (after every five rows installed) and adjust them, if necessary, using a screwdriver.

Install paving stones up to the last row. To avoid having to cut paving stones later, determine the position of the curbs to finish with a complete paving stone.

If necessary, you can cut the paving stones using a cold chisel or specialized tool such as guillotine or a concrete saw (ref: photo #7). It is recommended that you use a chalk line to mark the paving stones to be cut. If you have to use a guillotine to cut the stones, make sure that the cut is at a slight angle as pavers cut this way are much easier to install. If you use a concrete saw, keep away from the paving stones already installed, since the dust and dirt from the sawing will permanently stain them. Wear safety glasses when cutting concrete products.

Proceed immediately with installation of Melville curbs, Lafitt Curbs, Celtik curbs or plastic curbs on the perimeter of the paved surface (ref. photo # 8). The curbs are laid directly on the densified granular foundation.

GENERIC PAVERS (CONT'D)

6 FILLING THE JOINTS

Once you have finished laying the paving stones, stabilize them using a vibrating plate (ref: photo #9). This operation will settle the stones into the bed while levelling the surface. Begin by brushing a thin uniform layer of joint-filling sand over the paving stones and into the joints (ref: photo #10), and then use a vibrating plate. For best results, run the plate two or three times in each direction. This operation will allow the sand to penetrate suitably into the joints and the paving stones to settle approximately 10 mm - 3/8 in. into the bed. (For improved performance, use Techniseal polymeric sand in accordance with the instructions provided on the bag).

The installation of a detachable neoprene sole (or layer) has been proven to be an additional protection against the risk of concrete spalls when filling the joints of paving stones.

Repeat the sand-spreading and vibrating procedures until all of the paving-stone joints have been filled. Remove the excess sand with a brush. The final level of the sand in the joints should be about 3 mm - 1/8 in. lower than the level of the paving stones.

If, after a few days, some joints are not properly filled, repeat the procedure. It is recommended to perform an annual maintenance of the joints between the paving stones.

WE SUGGEST SETTING ASIDE A NUMBER OF PAVING STONES FOR REPLACEMENT.



TYPICAL CROSS-SECTION - PAVERS

TYPICAL PAVER INSTALLATION WITH MELVILLE, LAFITT OR CELTIK CURB

- Ⓐ Paving stones
- Ⓑ Laying bed 25 mm - 1 in. (concrete sand)
- Ⓒ Compacted granular foundation 0 to 20 mm - 0 to 3/4 in.
- Ⓓ Melville, Lafitt or Celtik curb

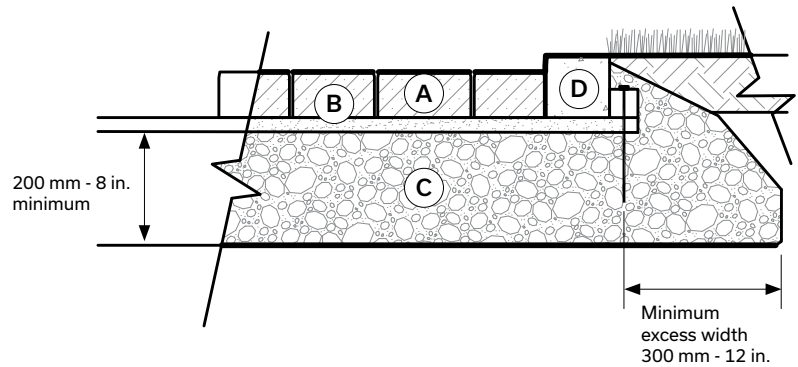

TYPICAL PAVER INSTALLATION WITH NOVO CURB

- Ⓐ Paving stones
- Ⓑ Laying bed 25 mm - 1 in. (concrete sand)
- Ⓒ Compacted granular foundation 0 to 20 mm - 0 to 3/4 in.
- Ⓓ Novo curb

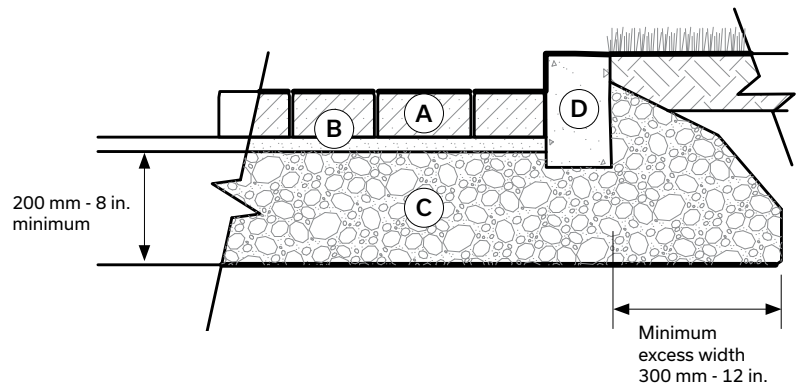

EXCAVATION DEPTH AND MINIMUM FOUNDATION⁽³⁾

NATURE OF PROJECT	GARAGE ENTRANCE		PATIO OR SIDEWALK	
NATURE OF SOIL	Clay ⁽²⁾	Sandy	Clay	Sandy
MINIMUM EXCAVATION REQUIRED	400 mm 16 in.	300 mm 12 in.	350 mm 14 in.	250 mm 10 in.
MINIMUM FOUNDATION THICKNESS 0 TO 20 MM - 0 TO 3/4 IN. CRUSHED STONE	300 mm 12 in.	200 mm 8 in.	250 mm 10 in.	150 mm 6 in.
MINIMUM/MAXIMUM UNCOMPACTED INSTALLATION ⁽¹⁾ BED	15 mm to 25 mm 5/8 in. to 1 in.	15 mm to 25 mm 5/8 in. to 1 in.	15 mm to 25 mm 5/8 in. to 1 in.	15 mm to 25 mm 5/8 in. to 1 in.
THICKNESS OF PAVING STONE	60 mm or 80 mm 2 3/8 in. or 3 1/8 in.	60 mm or 80 mm 2 3/8 in. or 3 1/8 in.	60 mm or 80 mm 2 3/8 in. or 3 1/8 in.	60 mm or 80 mm 2 3/8 in. or 3 1/8 in.

The information in this table shows the minimum required for a job well done. Anything above this level means improved stability for the whole.

⁽¹⁾ Once compacted, a 25 mm - 1 in. bed will be reduced down to 15 mm - 5/8 in.

⁽²⁾ For certain areas where clay soil is unstable, the minimum excavation required is 600 mm - 24 in. and the minimum foundation is 525 mm - 21 in.

⁽³⁾ Conforms to the recommended ICPI standard (Interlocking Concrete Pavement Institute)

Paver Index

Pavers

Ecological Pavers:	
Cassara Verde Paver	8
Turfstone Paver	8
Virage Paver	8
Zen Paver	8
Virage Paver - Laying Patterns	13
Permeable Pavement:	
Mondrian Plus	26
Trafalgar 60	26
Vendome	26
Architectural Pavers:	
Agora Aqua Paver	31
Agora Paver	32

PACKAGING

For product packaging information, please refer to our Product Data Guide on our website.



English
Quebec



English
Ontario

NOTE: Please note that only pavers with specific notes are included in the guide. For information on our entire product line, please see our product guide.

The information contained in these technical documents is supplied for information purposes only. Any application of the information is the sole responsibility of the installer. The installer must ensure that the installation and use of permeable installation projects comply with local regulations and code requirements. A qualified engineer must be consulted for final design for construction purposes. Oldcastle Building Products Canada, Inc. and its affiliates cannot be held responsible for the improper use of information contained in these technical documents.

Ecological Pavers

SPECIFIC DETAILS

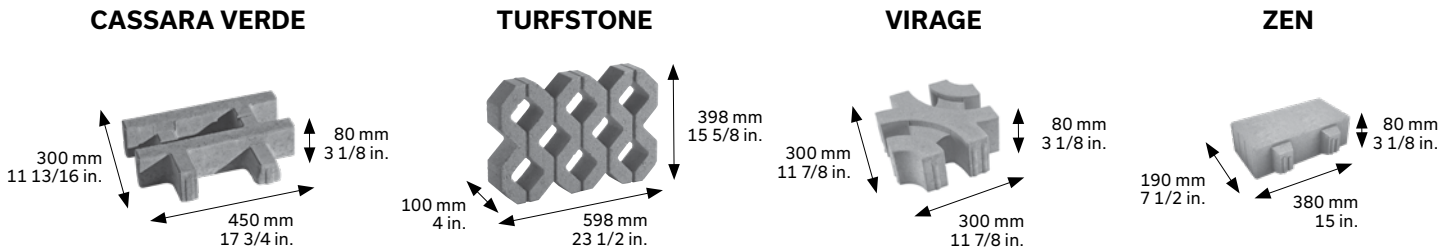

RESIDENTIAL VEHICULAR VEGETATED PAVEMENTS INCORPORATING PAVERS WITH MULTI-CAVITY

Whether they are filled with clean aggregates to improve water infiltration into the soil or vegetated to reduce urban heat islands and capture harmful CO₂ from the air, permeable pavers allow you to create an environment-friendly space tailored to your taste.

ADVANTAGES

- > Significantly reduces heat island effects
- > Better management of rainwater: slow-down of runoff water
- > Improves air quality
- > Create more natural and soothing spaces for the population

APPLICATIONS

- > Residential parking, driveways, picnic areas and pedestrian walkways

IMPLEMENTATION

Filling paver cells: Soil mix for grassing, sodding and tree planting. Professional blend composed of mineral soil, sand, fibrous black earth and compost. Available at bulk landscape suppliers, specialized garden centres and soil mix manufacturers. Fill the cells. Pass vibrating plate. Water the surface. Spread the grass seeds.

GRASS SEED : two recommended brands

Minimum maintenance blend (2-week germination):

63% Fescue, 20% Perennial Ryegrass, 17% Kentucky Bluegrass

Sports field blend - high traffic resistance (3-week germination): 65% Kentucky Bluegrass, 20% Fescue, 15% Perennial Ryegrass

SEED BED

Cover the grass seeds with a maximum of 10 mm of soil mix for grassing, sodding and tree planting, then water slightly.

FERTILIZERS: NITROGEN (N), PHOSPHORUS (P), POTASSIUM (K)

Application of fertilizers is recommended for the first year. An organic-based fertilizer is adequate. The following ratios (N-P-K) may be used: 4-1-2, 3-1-1, 2-1-1 (formulation example: 19-6-4)

GERMINATION COVER FOR SEED BED PROTECTION

A woven fabric designed to protect the seed bed allows moisture retention and prevents soil erosion during heavy rains.

IRRIGATION

During the first year of implementation, you must provide an irrigation system for 7 to 8 weeks.

Then irrigate as needed in the morning such that the soil throughout the depth of the cells is moistened.

Product	Void Opening	Infiltration Rate
Cassara Verde Paver	50%	N/A
Turfstone Paver	40%	2544 in./hour
Virage Paver	47%	N/A
Zen Paver	27%	N/A

PLANTING DIAGRAM OF LAWN GRASSES IN ECOLOGICAL PAVERS

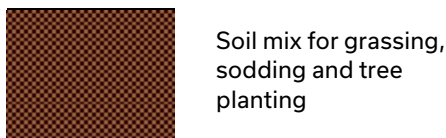

COMPACT



WATER

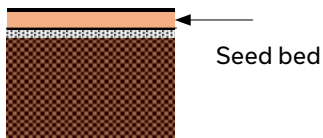
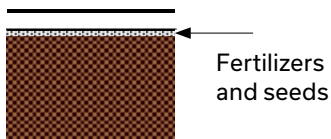

WATER

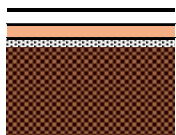

STAGES OF FILLING AND ESTABLISHMENT OF GRASS

- > Fill the cells with soil mix for grassing, sodding and tree planting
- > Spread without compacting
- > Level with the paver surface
- > Apply (vibrating plate with rubberized protection)
- > Compact the pavers (vibrating plate with rubberized protection)
- > Water to obtain soil packing enabling the addition of the seed bed
- > Ensure 5-10 mm of clearance under the paver surface and adjust (if required)
- > Spread out fertilizers and seeds
- > Spread the seed bed and level
- > Water lightly to moisten the seed bed

NOTE: The seed bed is the soil mix for grassing, sodding and tree planting. Shown here on the left are the grass filling and planting steps. The succession of steps should prevent the seeds from being more than 10 mm below the seed bed so that they do not rot.

MAIN INTERVENTION TO MAINTAIN THE INITIAL VEGETATION IN PLACE

EXTENSIVE APPROACH WITH MINIMAL MAINTENANCE REQUIRED:

- > A traditional vegetation planting approach: selection of undemanding plants
- > One fertilization per year: from irrigation process to planting
- > Minimal interventions for natural growth of the vegetation in the cells

INTENSIVE APPROACH WITH MULTIPLE INTERVENTIONS (GREATER CHANCE OF SUCCESS):

- > A traditional approach of planting vegetation (grass)
- > Regular irrigations in season (mandatory in drought period)
- > Periodic manual weeding (preferred)
- > Replacement of vegetation as needed (reseeding)
- > Addition of soil mix annually
- > Regular fertilization in season

USE OF HERBACEOUS PERENNIALS TO REPLACE LAWN GRASSES

It is important to note that the turf installed in the ecological pavers is demanding in terms of water and fertilizer and is not very resistant to dryness. Intensive maintenance interventions approach increase the chances of success. In addition, hardy ground cover crops that are very drought-resistant and low in fertilizer may provide a better alternative.

In this sense, several plants were selected and tested to establish their drought resistance and their demand for water and fertilizer. Overall, the plants that we propose here exceed the potential of the more demanding lawn. The use of these plants should be considered when an extensive approach (minimal maintenance interventions) is recommended.

- > Veronica Repens
- > Pilosella aurantiacum (hawkweed)
- > Sedum album *Coral Carpet*
- > Thymus serpyllium *Magic Carpet*
- > Sedum acre

TIPS

- > Use plants produced in multi-cell at the rate of 2 per single alveolus
- > Cutting implantation (for SEDUM) is possible and takes root more quickly
- > Plants exposed to full sun will have smaller leaves than normal because they adapt
- > Plants are available in specialized horticultural centers (Aux Aubepines for example)
- > The substrate (potting soil) to be considered must not contain an excessive mineral component

MAINTENANCE RECOMMENDATION

SEASONAL IRRIGATION

Irrigation is necessary during the first year of planting

MOWING

Mowing to 8-10 cm - 3 and 4 in. is recommended for the entire growing season. Avoid mowing during drought periods.

WEEDING CONTROL

Extensive approach: leave what nature provides
Intensive approach: manual weeding can be performed in season

FERTILIZATION PROGRAM (N-P-K)

Proceed with at least one fertilization per year (extensive approach). For optimal results, three fertilizations per year are required.

ADDING SOIL MIX

Addition of soil mix is performed from the end of August to mid-September as well as in the spring. It maintains fertility and restores the filling level (if packing is observed) for optimum clearance (6 to 10 mm) below the paver surface.

RESEEDING

Increases grass density. The dense presence of vegetation associated with a strong root system avoids compaction. Reseeding is performed at the same time as the addition of soil mix, between mid-August and mid-September and in the spring.

WINTER

De-icing salts application is prohibited. Ice clumps under vehicles are also a threat to the plants. Snow removal height must be adapted to leave a tamped snow cover of 2 to 4 cm, which will protect the plants from cold spells and prevent their uprooting during snow removal.

ECOLOGICAL PAVERS

CASSARA VERDE PAVERS CROSS-SECTION - RESIDENTIAL DRIVEWAY

PLAN VIEW

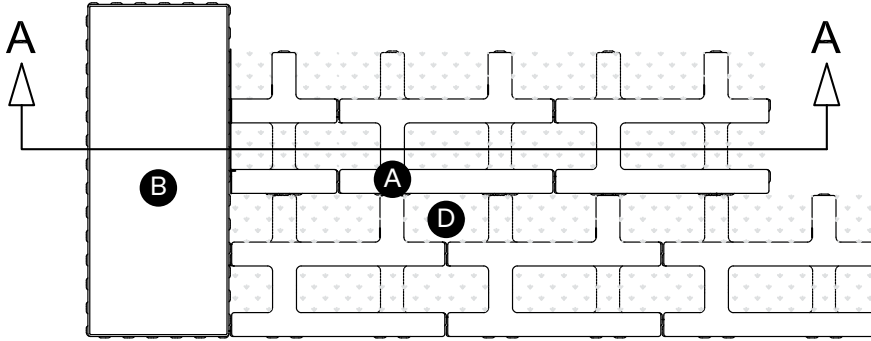

CROSS-SECTION A-A

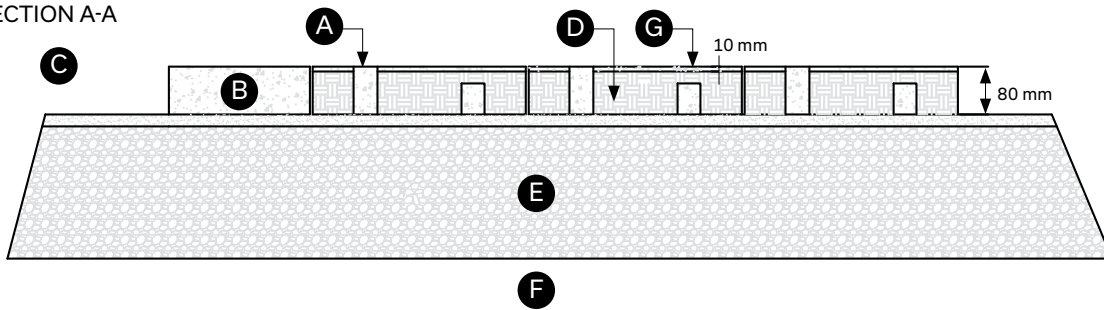

- Ⓐ Cassara Verde paver (80 x 300 x 450 mm)
- Ⓑ Cassara Large Rectangle paver
- Ⓒ Installation bed 12 to 25 mm: clean stone, 9.5 mm - 3/8 in.
- Ⓓ Soil mix for grassing, sodding and tree planting (inside the multi-cavity).
The soil mix is also used as seed bed (for grass).
- Ⓔ 20 mm - 3/4 in. clean stone compacted to 95% modified Proctor
- Ⓕ Existing soil with adequate bearing capacity (minimum of 150 kN/m²)
- Ⓖ Maximal clearance of 10 mm under the paver surface

NOTE: The Cassara Verde paver is used in combination with the Cassara Large Rectangle, Esbelto or Melville pavers.

EXAMPLE OF INSTALLATION

Residential driveway. Cassara Verde paver.

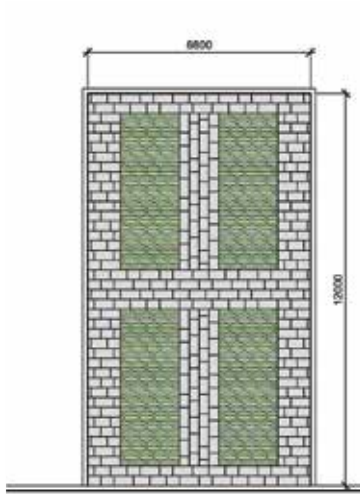

OPTION ①

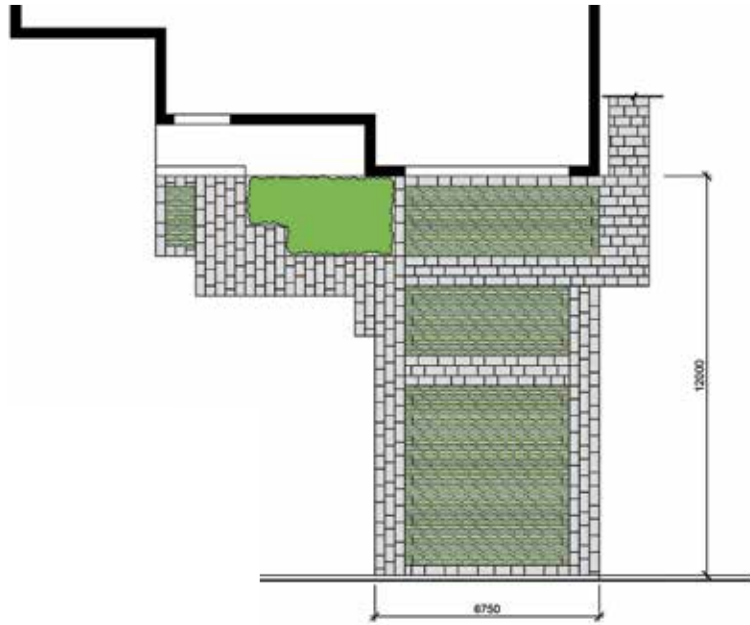

OPTION ②

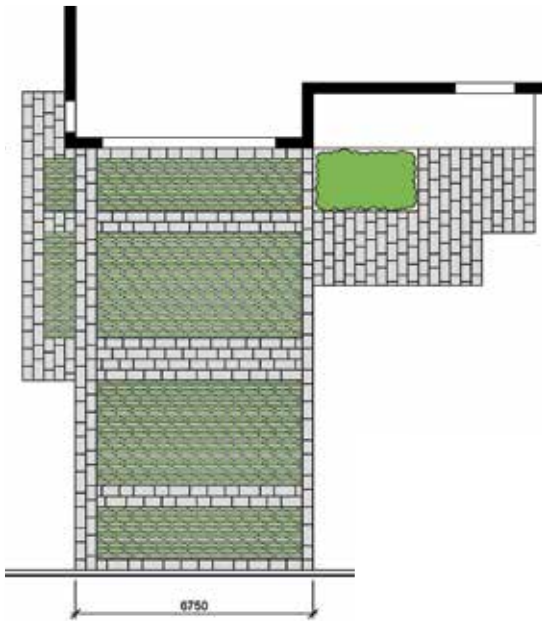

OPTION ③

Virage Paver

DESCRIPTION



The unique Virage pavers, inspired by European innovations, transform any exterior design into a true architectural masterpiece. With only a single paver, six laying patterns are possible, each more creative than the other.

Whether they are filled with clean aggregates to improve water infiltration into the soil or vegetated to reduce urban heat islands and capture harmful CO₂ from the air, Virage pavers allow you to create an environment-friendly space that reflects your image.

UNIT

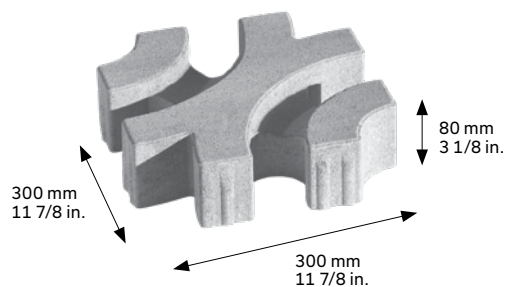

VIRAGE PAVER

LAYING PATTERNS

The six patterns are created with the singular Virage Paver unit, simply by rotating it. Virage Paver is always installed in a stack bond pattern, which means all the units are installed on top of one another with the joints in the same position.

All following patterns start in the same way: by laying down the first Virage unit like shown below (follow the red corner). Next, install the second Virage unit, either in the same angle or with a 90° rotation (so, turn it once), according to the chosen pattern. Then, continue the section as many times as necessary to cover the area of the project.

Base unit:



BEADED PATTERN



CIRCLE PATTERN



LINK PATTERN



MOSAIC PATTERN



RANDOM PATTERN



WAVE PATTERN



BEADED PATTERN



Beaded pattern is created by installing all the units in the same 0° angle:

1

Lay down the first unit, red corner at the top right (0°)



2

Lay down all units, red corner at the top right (0°)

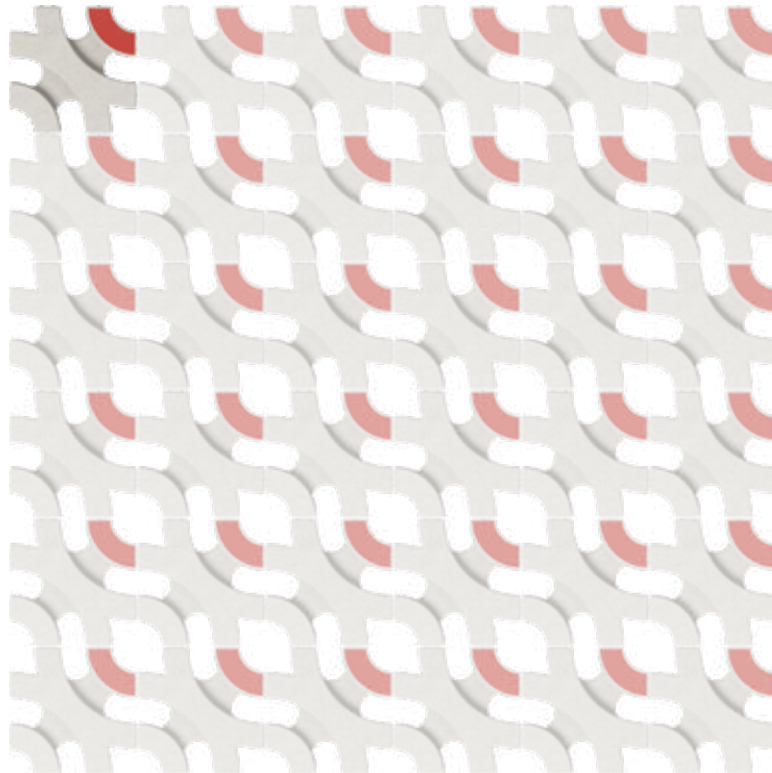

CIRCLE PATTERN



Circle pattern is a 2 x 2 section that repeats itself:

1

Lay down the first unit, red corner at the top left (90°)



2

Lay down the second unit on the right, red corner at the top right (0°)



3

Lay down the third unit below, red corner at the top right (0°)

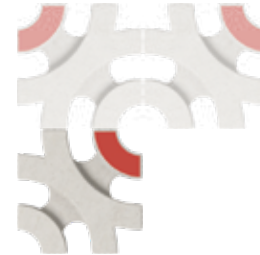

4

Lay down the fourth unit on the right, red corner at the top left (90°)

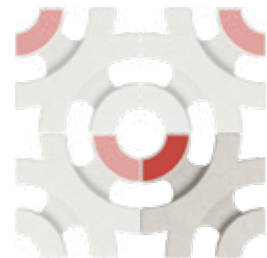

5

Repeat the section as many times as needed to complete the project



LINK PATTERN



Link pattern is a 5 x 2 section that repeats itself:

1

Lay down the first unit, red corner at the top right (0°)



2

Lay down the second unit on the right, red corner at the top right (0°)



3

Lay down the third unit on the right, red corner at the top right (0°)



4

Lay down the fourth unit on the right, red corner at the top right (0°)



5

Lay down the fifth unit on the right, red corner at the top right (0°)



6

Lay down the sixth unit below, red corner at the top right (0°)



7

Lay down the seventh unit on the right, red corner at the top left (90°)

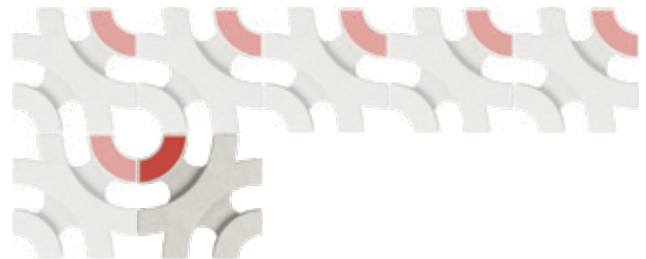

LINK PATTERN - CONT'D

8

Lay down the eighth unit on the right, red corner at the top right (0°)

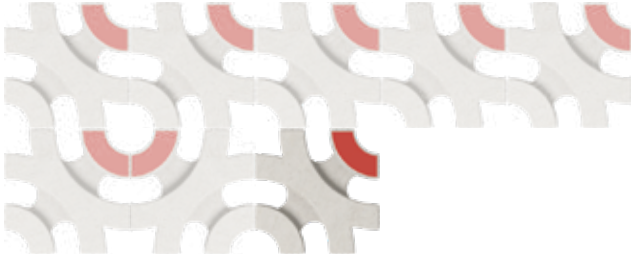

9

Lay down the ninth unit on the right, red corner at the top left (90°)



10

Lay down the tenth unit on the right, red corner at the top left (90°)



11

Repeat the section as many times as needed to complete the project

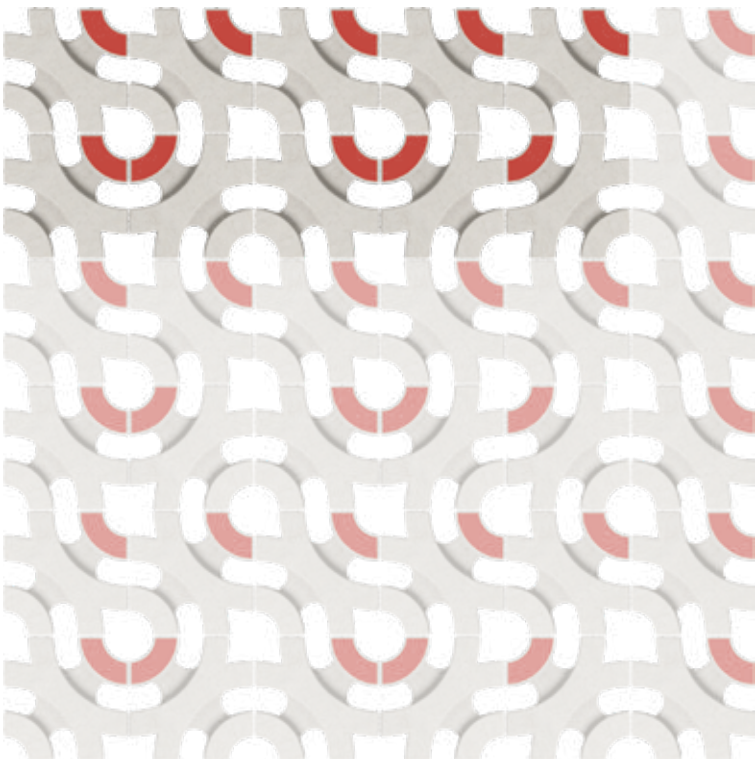

MOSAIC PATTERN



Mosaic pattern is a 6 x 6 section that repeats itself. For explanation purposes, the section is broken down in 6 rows of 6 units wide:

Row A: 6 x 1

1

Lay down the first unit, red corner at the top right (0°)



2

Lay down the second unit on the right, red corner at the top left (90°)



3

Lay down the third unit on the right, red corner at the top right (0°)



4

Lay down the fourth unit on the right, red corner at the top right (0°)



5

Lay down the fifth unit on the right, red corner at the top left (90°)



6

Lay down the sixth unit on the right, red corner at the top left (90°)



MOSAIC PATTERN - CONT'D

ROW B: 6 x 1

1

Lay down the first unit, red corner at the top right (0°)



2

Lay down the second unit on the right, red corner at the top left (90°)



3

Lay down the third unit on the right, red corner at the top left (90°)



4

Lay down the fourth unit on the right, red corner at the top right (0°)



5

Lay down the fifth unit on the right, red corner at the top left (90°)



6

Lay down the sixth unit on the right, red corner at the top left (90°)



ROW C: 6 x 1

1

Lay down the first unit, red corner at the top right (0°)



2

Lay down the second unit on the right, red corner at the top right (0°)



3

Lay down the third unit on the right, red corner at the top right (0°)



4

Lay down the fourth unit on the right, red corner at the top right (0°)



5

Lay down the fifth unit on the right, red corner at the top right (0°)









6

Lay down the sixth unit on the right, red corner at the top right (0°)









MOSAIC PATTERN - CONT'D

ROW D: 6 x 1

<p>1</p> <p>Lay down the first unit, red corner at the top right (0°)</p> 	<p>2</p> <p>Lay down the second unit on the right, red corner at the top left (90°)</p> 	<p>3</p> <p>Lay down the third unit on the right, red corner at the top right (0°)</p> 
<p>4</p> <p>Lay down the fourth unit on the right, red corner at the top right (0°)</p> 	<p>5</p> <p>Lay down the fifth unit on the right, red corner at the top right (0°)</p> 	
<p>6 Lay down the sixth unit on the right, red corner at the top right (0°)</p> 		

ROW E: 6 x 1

<p>1</p> <p>Lay down the first unit, red corner at the top right (0°)</p> 	<p>2</p> <p>Lay down the second unit on the right, red corner at the top right (0°)</p> 	<p>3</p> <p>Lay down the third unit on the right, red corner at the top right (0°)</p> 
<p>4</p> <p>Lay down the fourth unit on the right, red corner at the top right (0°)</p> 	<p>5</p> <p>Lay down the fifth unit on the right, red corner at the top left (90°)</p> 	
<p>6 Lay down the sixth unit on the right, red corner at the top left (90°)</p> 		

COMPLETE SECTION

Repeat the section in order A-B-C-D-E-C as many times as needed to complete the project

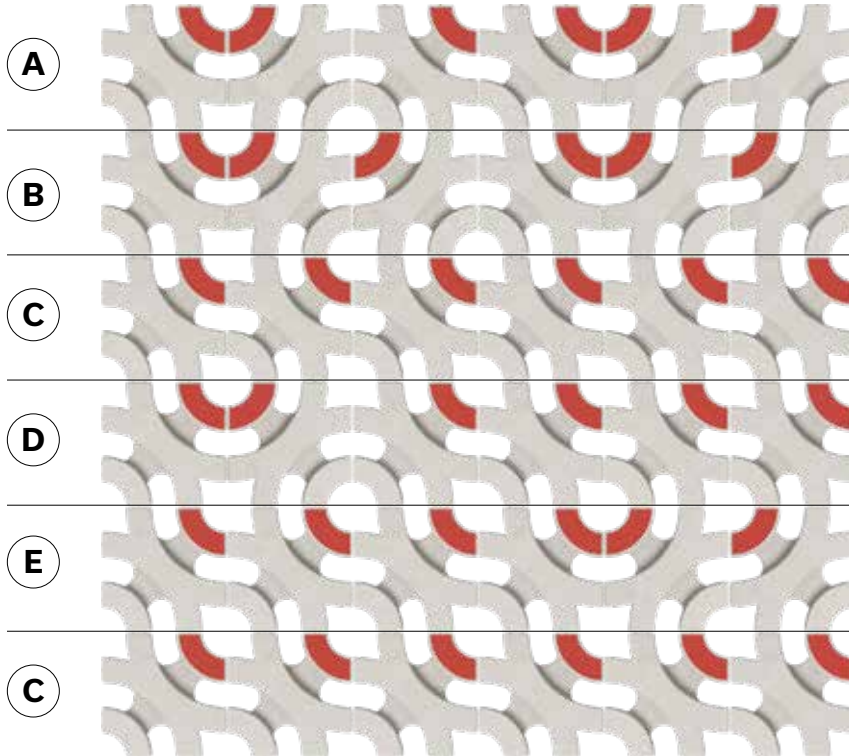

RANDOM PATTERN



Random pattern is a 3 x 3 section that repeats itself:

<p>1</p> <p>Lay down the first unit, red corner at the top right (0°)</p>	<p>2</p> <p>Lay down the second unit on the right, red corner at the top left (90°)</p>	<p>3</p> <p>Lay down the third unit on the right, red corner at the top right (0°)</p>
<p>4</p> <p>Lay down the fourth unit below, red corner at the top left (90°)</p>	<p>5</p> <p>Lay down the fifth unit on the right, red corner at the top right (0°)</p>	<p>6</p> <p>Lay down the sixth unit on the right, red corner at the top left (90°)</p>
<p>7</p> <p>Lay down the seventh unit below, red corner at the top right (0°)</p>	<p>8</p> <p>Lay down the eighth unit on the right, red corner at the top left (90°)</p>	<p>9</p> <p>Lay down the ninth unit on the right, red corner at the top right (0°)</p>

10

Repeat the section as many times as needed to complete the project.



WAVE PATTERN



Wave pattern is a 2 x 1 section that repeats itself:

1

Lay down the first unit, red corner at the top right (0°)



2

Lay down the second unit on the right, red corner at the top left (90°)



3

Repeat the section as many times as needed to complete the project.

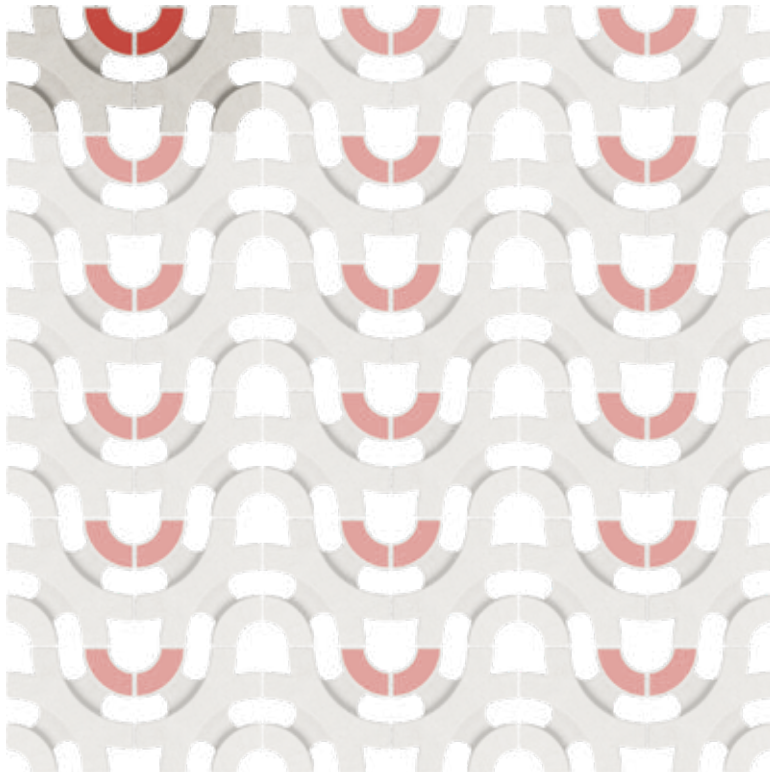

Permeable Pavement



SPECIFIC DETAILS

ROLE OF PERMEABLE PAVEMENT

The objective, when building a permeable pavement system, is to allow rainwater to infiltrate the underlying soil. The stormwater will be stored in the subbase of the paved area instead of running off to the sewer system. The open graded subbase material will provide storage for the runwater that is collected and will be held for a period of time. Subsequently, the natural permeability of the soil beneath the subgrade will allow the accumulated water to gradually return to the ground table, thus pursuing its natural cycle.

CONCRETE PAVERS USED IN THE CONSTRUCTION OF PERMEABLE PAVEMENT

Specifically designed concrete pavers can be used for the construction of a permeable pavement. The joints between the pavers, which are filled with a permeable granular material, have the required porosity to channel water into the system.

DESIGN AND CONSTRUCTION

Before undertaking any construction work, an engineer experienced in the field of hydrology should be consulted, in order to obtain an accurate history of local precipitation and the amount of rainwater or drainage from neighbouring surfaces that will run through the permeable paved area.

MONDRIAN PLUS PAVERS



126 IN./HR

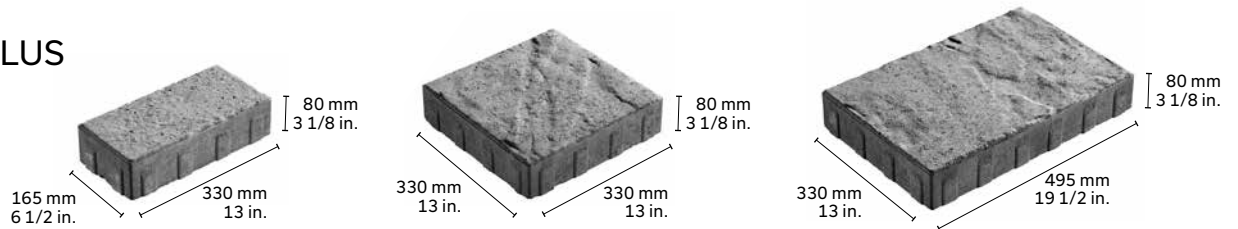

TRAFALGAR 60 PAVERS



484 IN./HR

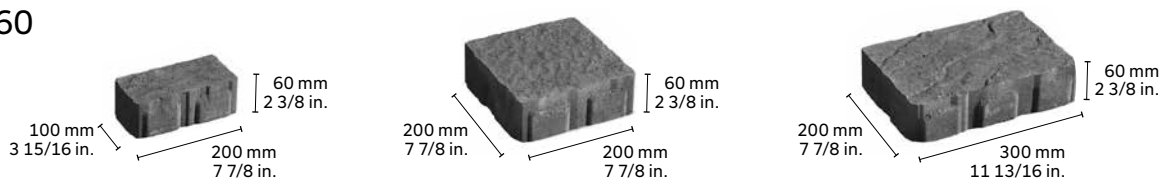

VENDOME PAVERS



890 IN./HR

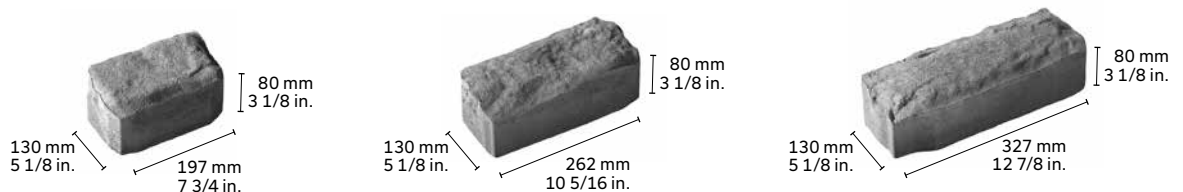

TECHNOLOGY - DESIGN AND CONSTRUCTION

A detailed study is also required to determine the permeability of the undisturbed soil present beneath the permeable materials, as well as proximity to the groundwater table, rock bed, etc. The technical data gathered will make it possible to design effective permeable pavement**, i. e., pavement where the volume of the subgrade's intergranular basin is sufficient to collect the projected amount of rainwater, and where the permeability of the soil is adequate (permeability coefficient exceeding $2 \times 10^{-6} \text{m/sec.}$ or 0.27 inches/hour) to allow the water to return naturally to the groundwater table before another major rainfall. Failing this, it will be necessary to build a drainage system into the subbase, perhaps even on the surface of the pavement (which should

always have a minimum 1% slope) as a complementary measure to evacuate residual rainwater and avoid any overflow or flooding of the structure in service. Melting snow and winter rains must also be taken into account.

Construction must be carried out by a competent contractor in strict compliance with plans and specifications. Moreover, materials must be selected with considerable care to obtain the required permeability. (The minimum requirement for the permeability of the pavers is 100 in/hr).

TYPICAL CROSS-SECTION OF A PERMEABLE PAVEMENT

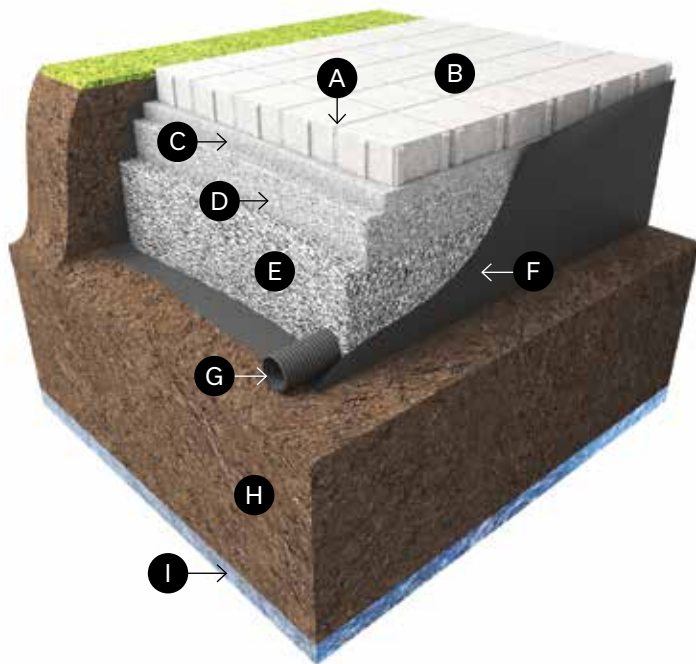

- A** Joint filler - 2.5 to 5 mm clean stone
- B** Permeable paver
- C** Compacted bedding (50 mm max.) 2.5 to 10 mm clean stone
- D** Compacted upper subbase (100 to 150 mm) 14 to 28 mm clean stone
- E** Compacted lower subbase (min. 300 mm) 40 to 80 mm clean stone
- F** Geotextile
- G** Optional perforated drain (see ICIP recommendations)
- H** Subgrade (thickness: min. 600 mm)
- I** Groundwater table (or cliff)

* Permacon strongly recommends the CMHA website (Concrete Masonry & Hardscapes Association): www.masonryandhardscapes.org/technical-resources/#hardscapes-tech before undertaking any studies or work on permeable pavement using concrete pavers.
 ** Application software has been developed for this purpose. See the CMHA website.

The information contained in these technical documents is supplied for information purposes only. Any application of the information is the sole responsibility of the installer. The installer must ensure that the installation and use of permeable installation projects comply with local regulations and code requirements. A qualified engineer must be consulted for final design for construction purposes. Oldcastle Building Products Canada, Inc. and its affiliates cannot be held responsible for the improper use of information contained in these technical documents.

ADVANTAGES AND BENEFITS

These can be summarized as follows:

- > Excellent way of avoiding the construction of new impermeable surfaces
- > Significantly reduces the volume of rainwater channelled to a storm sewer
- > Eliminates the need to dig catch basins for surface water
- > Reduces the quantity of toxic and suspended matter in the storm system
- > Improves the comfort and safety of users during rainfalls (survival of the natural environment, plants, trees, etc.)
- > Actively contributes to reloading the groundwater table
- > Reduces occasional risk of flooding paved areas
- > Reduces the risk of soil erosion by reducing the runoff speed of surface water
- > Reduces development costs in new sectors, by avoiding oversized rainwater management works
- > Provides a durable concrete paver structure capable of withstanding freeze-thaw cycles and deicing salts
- > Favours sustainable development - possibility of earning 2 LEED points (Leadership in Energy and Environmental Design) from the Canada Green Building Council) - in the area of ecological site development, paragraph 6. 1 *Flow and Quantity* and paragraph 6. 2 *Water Treatment*

A MINIMAL SEASONAL MAINTENANCE ALLOWS AN ADEQUATE PERFORMANCE OF THE STRUCTURE THAT CAN EXCEED 25 YEARS.

PERMEABLE PAVEMENT LIMITATIONS

While permeable pavement provides many advantages, it should be recalled that it is not the solution for every project that comes up. It does have its shortcomings, as shown below:

- > Requires greater design and construction expertise
- > A solution that should be avoided in the presence of rock or a groundwater table too close to the surface [distance of less than 600 mm - 24 in.]
- > A solution that should be avoided where there are steep slopes near the permeable pavement (slopes exceeding 20%)
- > A solution that should be avoided when the permeable pavement's slope exceeds 5%
- > High risk of contaminating the groundwater reservoir near the draining subgrade (minimum 30-metre protective strip required, in keeping with prevailing regulations)
- > High risk of progressive clogging of the drainage layers over the long term, because of the significant quantity of fine particles in suspension. These result in particular from the application of road abrasives rich in fine particles, and which could, over time, reduce the structure's permeability. With a minimum of seasonal maintenance, the structure could perform effectively for more than 25 years.
- > A solution that should be avoided when a road's standard base course is too close to the drainage layer (minimum 6 m protective zone required)

PERMEABLE PAVEMENT CROSS-SECTION (RESIDENTIAL)

PLAN VIEW

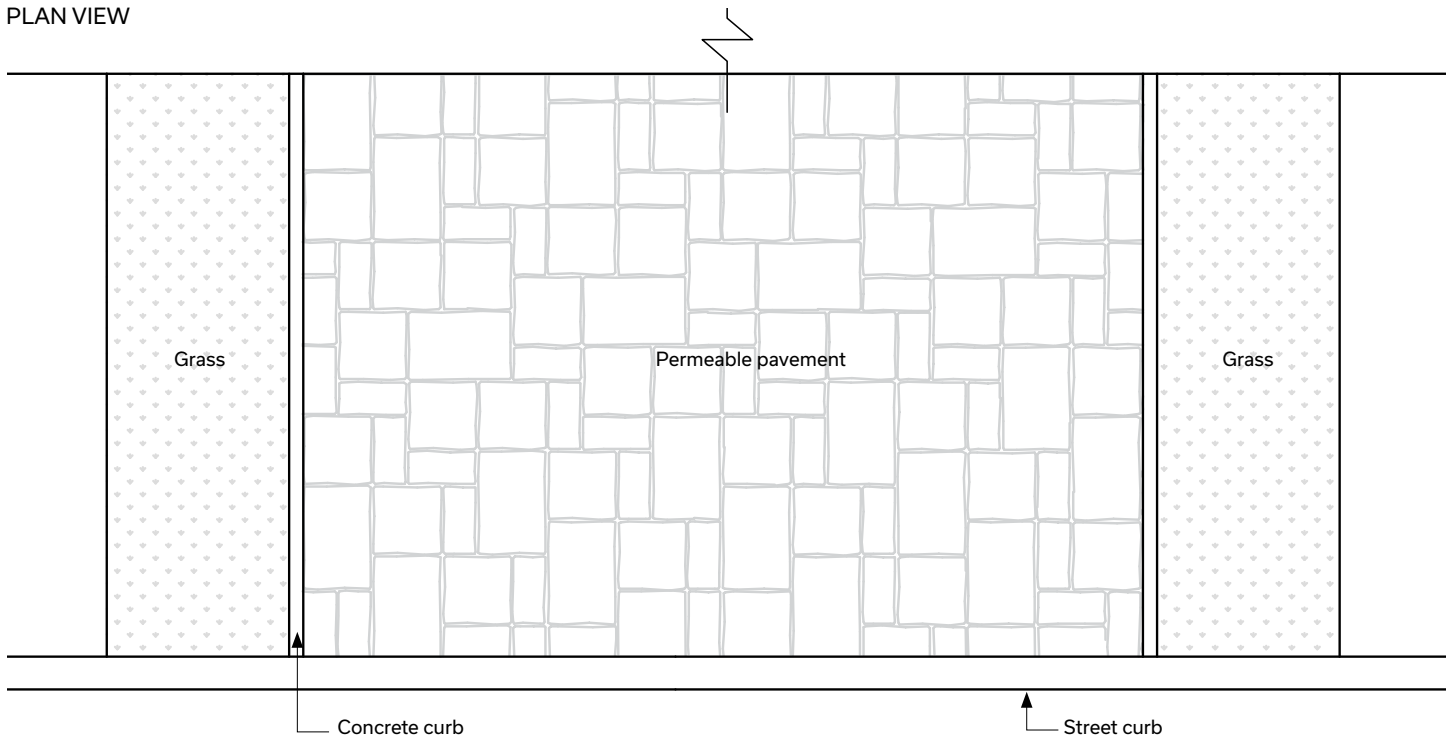

CROSS-SECTION

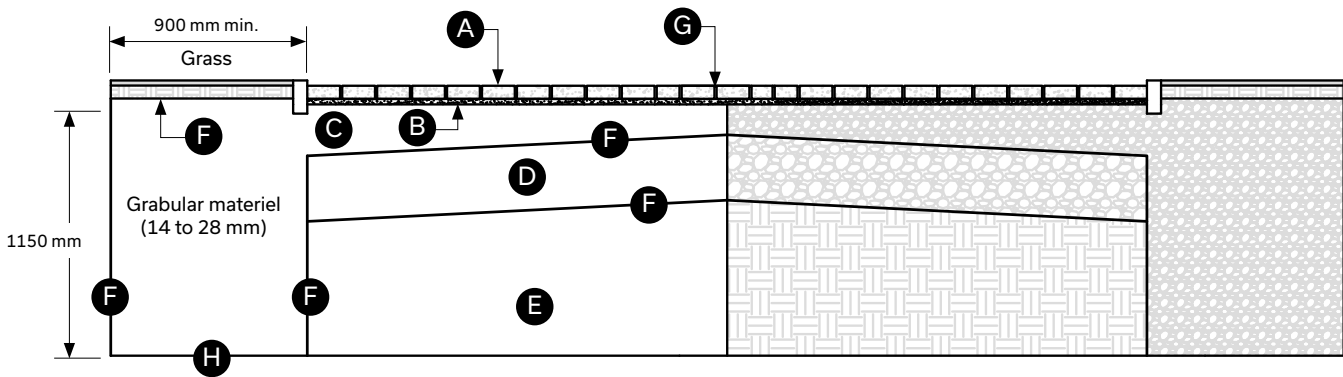

- Ⓐ Permeable paver 60, 80 or 100 mm (Mondrian Plus, Trafalgar, Vendome, Agora Aqua, AquaPave, Boulevard Drain)
- Ⓑ Open-graded bedding course 25 to 50 mm (open-graded aggregate 2.5 to 5 mm)
- Ⓒ Upper base, open-graded aggregate 100 to 150 mm (clean stone 14 to 28 mm)
- Ⓓ Lower aggregate base 300 to 450 mm (0 to 20 mm clean stone) compacted to 95% modified Proctor density
- Ⓔ Existing soil with adequate bearing capacity (minimum of 150 kN/m²)
- Ⓕ Geotextile membrane (with 2% minimum slope, if required)
- Ⓖ Permeable joint material (open-graded aggregate 2.5 to 5 mm)
- Ⓗ Existing soil with a minimum infiltration rate of 3 in/hour (to be validated with tests)

Architectural Pavers

INSTALLATION OF CONCRETE PAVERS

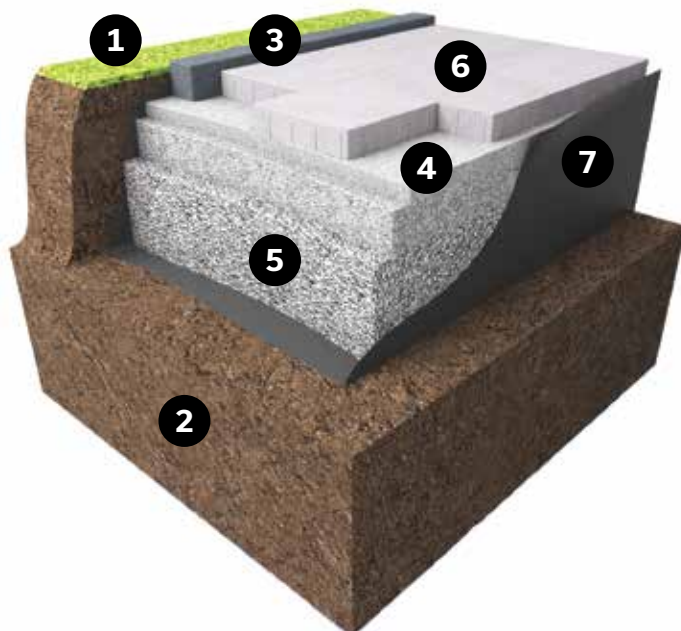

- ① Lawn
- ② Undisturbed soil
- ③ Curb
- ④ Laying bed
- ⑤ Compacted 0-20 mm - 0-3/4 in. granular base
- ⑥ Pavers
- ⑦ Geotextile membrane

Agora Aqua Paver

BASIC INSTALLATION



The Agora Aqua paver has a smooth, linear surface offering a contemporary look. Thanks to its mechanical installation, this paver is a quick solution for large urban environments. An eco-friendly paver that allows for the responsible management of runoff water.

LAYING PATTERN - MECHANICAL INSTALLATION

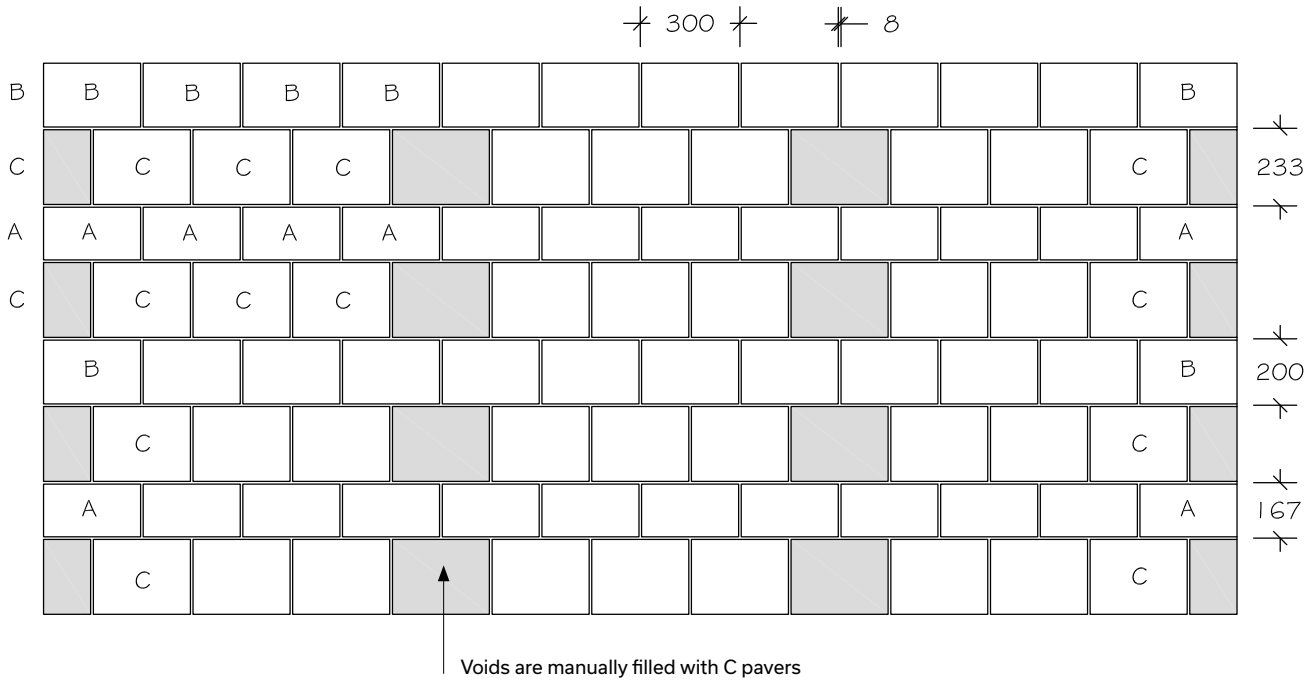

Agora Paver

BASIC INSTALLATION



The Agora paver offers a series of attributes ranging from aesthetics to functionality. The smooth finish, a perfect choice for landscape architects looking for a contemporary visual signature. The unique configuration allows a mechanical installation thus ensuring performance and speed.

LAYING PATTERN

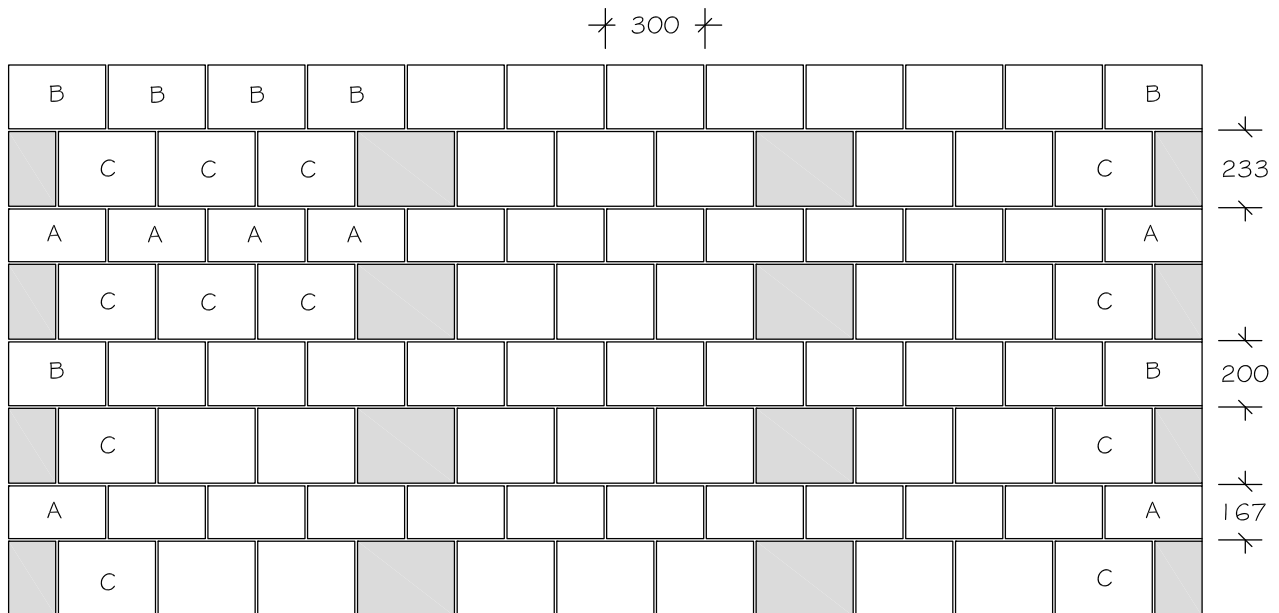

Slabs

SLAB INSTALLATION (GENERIC)

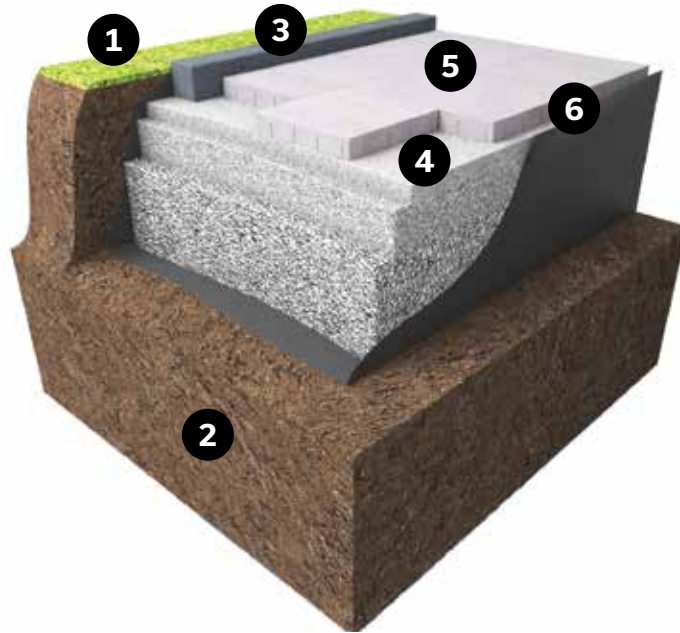

TOOLS REQUIRED

- > 1 wheelbarrow
- > A few pegs
- > 2 rigid pipes with a diameter of 25 mm - 1 in. x 3 m - 10 ft.
- > 1 plank: 25 mm x 150 mm x 2.4 m - 1 in. x 6 in. x 8 ft.
- > 1 plumb line
- > 1 level
- > 1 bricklayer's line: 15 m - 50 ft. long
- > 1 shovel
- > 1 chalk line
- > 1 measuring tape
- > 1 broom
- > 1 rake
- > 1 guillotine or concrete saw (available from rental stores)
- > 1 vibrating plate (compacting tool available from tool rental stores)

OPTIONAL TOOLS

- > Jumping jack

The jumping jack should not be used to compact slabs. It should only be used for the foundation.

1 EXCAVATION

If pipes or wires are located in the area to be excavated, contact the company representative concerned before the work is started.

To ensure sufficient drainage, excavate the soil to obtain a minimum incline of 2% (20 mm/m or 1/4 inch per foot). The slope may be further reduced to as little as 1% if there is good overall drainage on the site. When in doubt, obtain a detailed analysis of the site drainage (slopes, soil type, layout, etc.) from an expert.

The excavation contour should extend beyond the surface to be paved by at least 300 mm - 12 in. Ideally, this distance should be 1 to 1 1/2 times the thickness of the foundation. The stability of the project depends on this measurement, which ensures that the slabs at the edge will be as well supported as those in the centre.

Level the bottom of the excavation area with a rake and if the soil is sandy, compact it with a vibrating plate or roller. It is preferable not to pack clay soil at this stage. In this case, the use of a geotextile membrane placed between the natural soil and the foundation is recommended to prevent foundation contamination by clay and ensure greater stability. Refer to the chart to get the minimum excavation required (ref: photo #1)

2 FOUNDATION

Spread and compact the 0 to 20 mm - 0 to 3/4 in. stone in 100 mm - 4 in. layers. Lightly water the 0 to 20 mm - 0 to 3/4 in. stone to make tamping easier. To ensure an adequate foundation, compact the stone several times with a vibrating plate or a jumping jack (ref: photo #2). Once this stage has been completed, you will be able to see what the final result will look like; the surface should be uniform, with no bumps or depressions greater than 13 mm - 1/2 in. in 3 m - 10 ft. You can verify the final level for the slab installation by placing a slab on a guide (ref: photo #3). Adjust the surface, if necessary, with compacted 0 to 20 mm - 0 to 3/4 in. stone.

3 CURB

Installing Novo curb: Before you finish the foundation, proceed immediately with the installation of the curb. Begin by installing the curb on one side. Before installing the curb on the other side, temporarily place a row of slabs in order to determine the ideal distance and thus to determine the position of the other curbs and avoid having to cut slabs later. Installing Celtik curb, Melville curb or even a plastic curb: to install these types of curbs, see #5 LAYING THE SLABS on this page.

4 INSTALLATION BED

Spread the first layer of concrete sand between two 25 mm - 1 in. diameter steel pipes placed parallel to each other on the granular foundation (ref: photo #4). Level the material by sliding a straight plank across the two pipes (ref: photo #5). Compact the layer between the two pipes using a vibrating plate, without moving the pipes. Spread a second layer of uncompacted sand between the pipes to fill the space left by the compaction (approximate depth of 6 mm or 1/4 in.) and level once again using the straight plank. This method will facilitate the subsequent installation of the slabs. Fill the spaces left by the pipes which were used as levelling guides.

Repeat the same steps for the entire surface of the work. Any significant variation in the bed thickness may cause irregularities in the paved surface. Never use installation-bed material to make important corrections to the compacted granular foundation.

5 LAYING THE SLABS

Arrange the slabs according to the pattern chosen with a 90° angle if possible. Proceed by walking on the slabs (ref: photo #6).

Slabs are manufactured with side spacers that will set a space of 3 mm - 1/8 in. between each slab. A space of 2 mm must be allowed for slabs without spacers. The use of a bricklayer's line, a level, a square, and a specialized handling tool (possibly including vacuum lifting equipment) will be required.

To obtain an even distribution of colour and texture, it is recommended that you choose slabs from more than one cube at a time. Moreover, working across each cube always gives the best results.

Check the alignment of the slabs after every five rows installed and adjust them, if necessary, using a screwdriver. Also, check the uniformity of the surface regularly, and use a soft-head mallet to correct any units which do not meet the required degree of uniformity.

Install slabs up to the last row. To avoid having to cut slabs later, determine the position of the curbs to finish with a complete slab.

If necessary, you can cut the slabs using specialized tools such as guillotine or a concrete saw. It is recommended that you use a chalk line to mark the slabs to be cut. If you have to use a guillotine to cut the slabs, make sure that the cut is at a slight angle as slabs cut this way are much easier to install. If you use a concrete saw, keep away from the slabs already installed, since the dust and dirt from sawing will permanently stain them. Wear safety glasses when cutting concrete products.

At the perimeter of the slab-covered surface, proceed with installing the Melville curb, Lafitt curb, Celtik curb or a plastic curb (ref: photo #7). The curbs should be installed directly on the compacted granular foundation.

GENERIC SLABS (CONT'D)

6 FILLING THE JOINTS

Spread Techniseal polymeric sand on the slabs, then make it penetrate the joints by sweeping it in all directions (ref. photo # 8). (Follow the instructions indicated on the sand bags). Pass a small vibrating plate (see NOTE), protected by a rubber or neoprene membrane, over the entire surface to pack the sand solidly. Pass the vibrating plate a second time over the entire surface. Remove the surplus sand from the surface with a push broom. Level the surface of the joint with a leaf blower, then wet the surface to stabilize the polymer sand.

If, after a few days, some joints are not properly filled, repeat the procedure.

WE SUGGEST SETTING ASIDE A NUMBER OF SLABS FOR REPLACEMENT.

NOTE: For very large slabs and in places where a vibrating plate cannot be used, proceed with manual compaction of the sand by means of a rubber mallet, hammering vigorously on the four corners and the contour of each slab. Shearing the sand joints (manual compaction with an appropriate tool, such as a pointing trowel) may be necessary to ensure better densification.



TYPICAL CROSS-SECTION - SLABS

TYPICAL SLAB INSTALLATION

- (A) Slabs
- (B) Laying bed 25 mm - 1 in. (concrete sand)
- (C) Compacted granular foundation 0 to 20 mm - 0 to 3/4 in.
- (D) Melville, Lafitt, Celtik curb or other

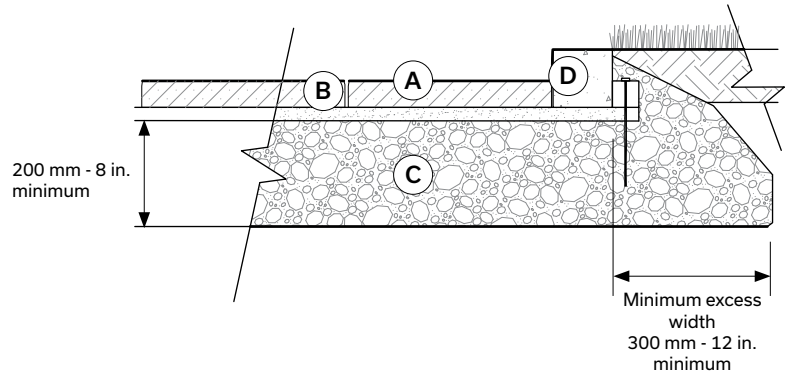

EXCAVATION DEPTH AND MINIMUM FOUNDATION⁽³⁾

NATURE OF PROJECT	PATIO OR SIDEWALK	
	Clay	Sandy
NATURE OF SOIL	Clay	Sandy
MINIMUM EXCAVATION REQUIRED	350 mm 14 in.	250 mm 10 in.
MINIMUM FOUNDATION THICKNESS 0 TO 20 MM - 0 TO 3/4 IN. CRUSHED STONE	250 mm 10 in.	150 mm 6 in.
MINIMUM/MAXIMUM UNCOMPACTED INSTALLATION ⁽¹⁾ BED	15 mm to 25 mm 5/8 in. to 1 in.	15 mm to 25 mm 5/8 in. to 1 in.
THICKNESS OF SLAB	Varies depending on selected slab	

The information in this table shows the minimum required for a job well done. Anything above this level means improved stability for the whole.

⁽¹⁾ Once compacted, a 25 mm - 1 in. bed will be reduced down to 15 mm - 5/8 in.

⁽²⁾ For certain areas where clay soil is unstable, the minimum excavation required is 600 mm - 24 in. and the minimum foundation is 525 mm - 21 in.

⁽³⁾ Conforms to the recommended ICPI standard (Interlocking Concrete Pavement Institute)

Slab Index

Slabs

Rosebel	38
Wilfrid	40

PACKAGING

For product packaging information, please refer to our Product Data Guide on our website.



English
Quebec



English
Ontario

NOTE: Please note that only slabs with specific notes are included in the guide. For information on our entire product line, please see our product guide.

Rosebel Slab

SPECIFIC DETAILS

A

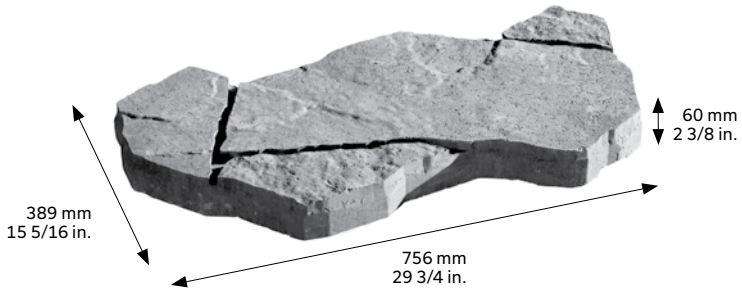

B

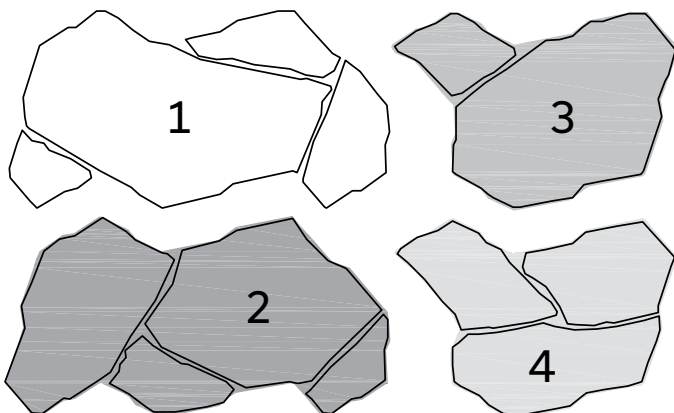
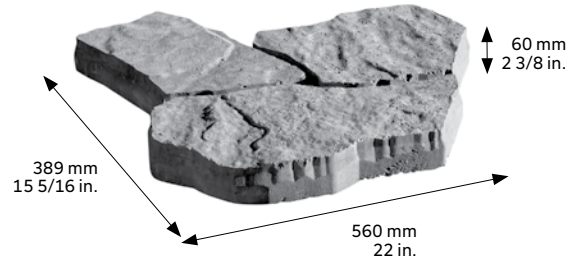

2 sizes of slabs, each with a different texture

INSTALLATION OF SLABS

BASIC PRINCIPLES: build a duo (pair) using both available slabs to reproduce a paving surface more accurately :

Vertical linear
(one under each other)

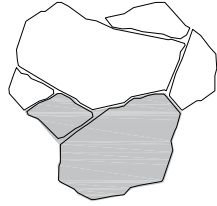

You can create 4 different duos (pairs) using four different formats: 1-3, 1-4, 2-3, 2-4

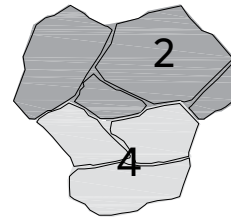
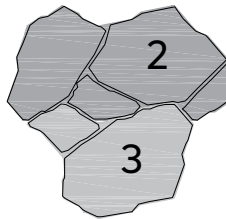
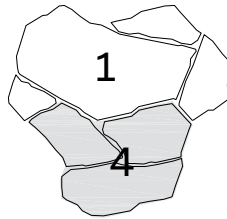
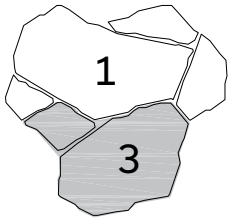

IF PLACED RANDOMLY, YOU CAN CREATE THE DESIRED PATTERN

The slabs can be turned on themselves with a 120° angle (1/3 turn) in one way or the other, then put in place at 30° one from the other. This will give less linear repetition of the joints.

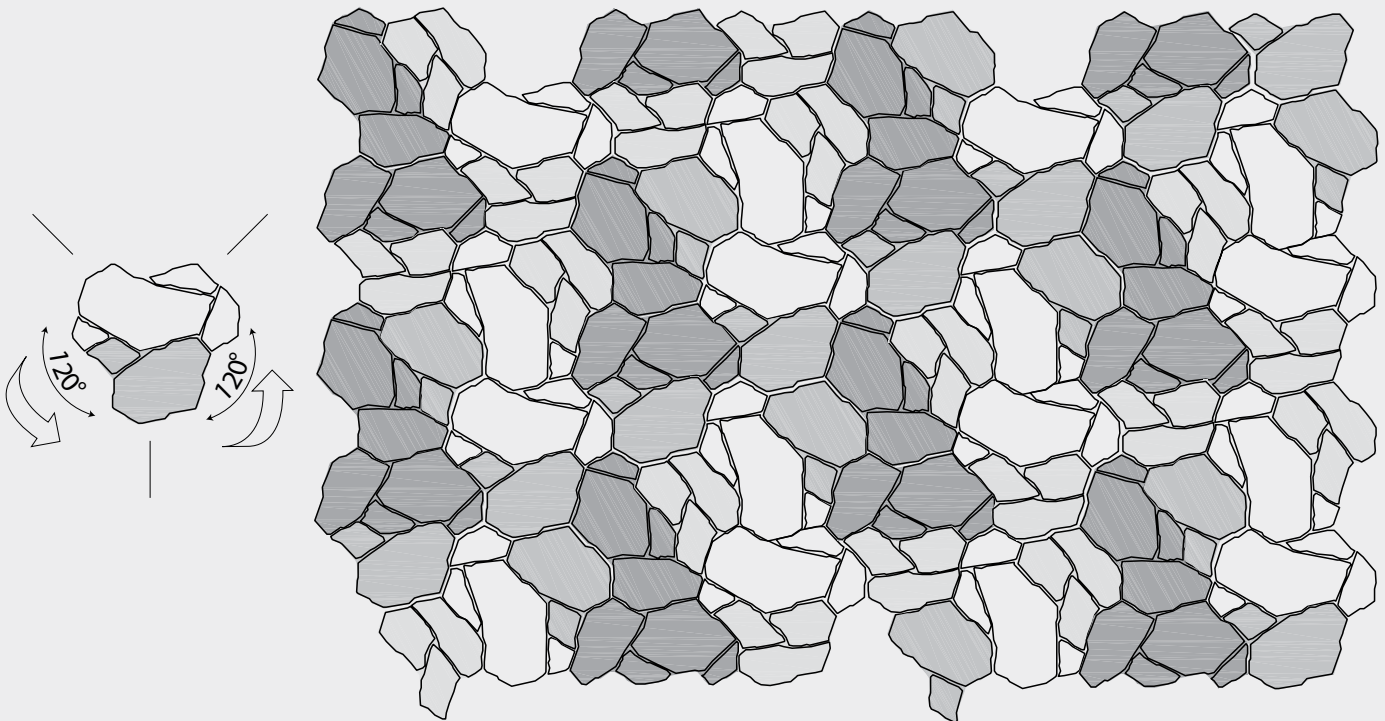

Wilfrid Slab

SPECIFIC DETAILS

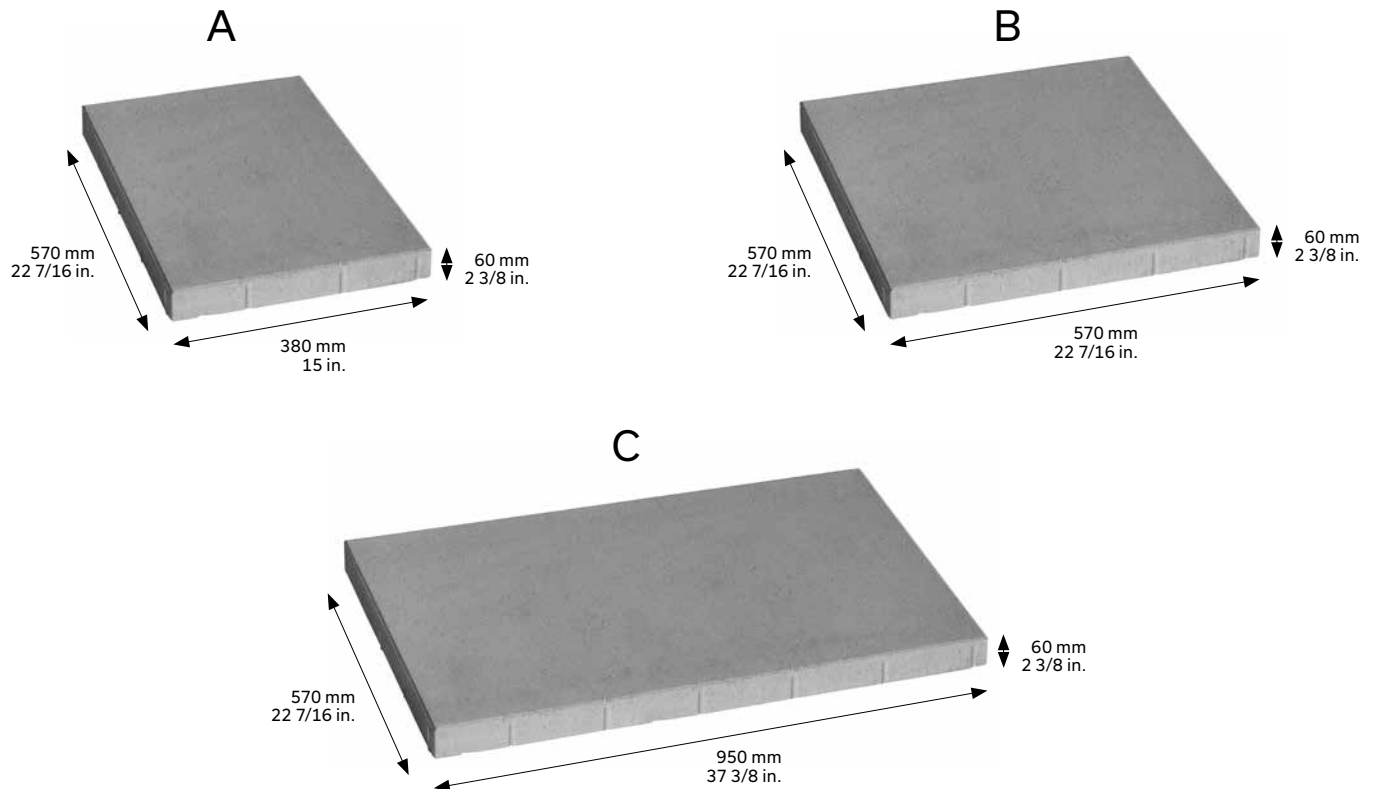

INSTALLATION OF SLABS

With its three sizes, the Wilfrid slab can be installed in a linear or modular pattern. It is recommended to use all units of every row to prevent waste when installing the Wilfrid Slab.

- > The unit ratio per layer is 1:1:1
- > The length of units A and B together equals the length of unit C
- > Unit A represents 1/3 and unit B represents 2/3 of the length of unit C

CAUTION! The unit ratio per layer of Wilfrid slab is not the same as the one of Melville 60 slab. The laying patterns for the Wilfrid slab are different.

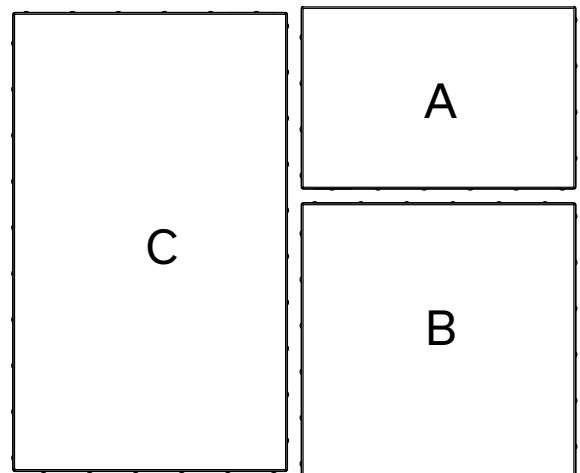

LAYING PATTERNS

LINEAR LAYING PATTERN

This is only a preview of a linear laying pattern. Replication of this exact pattern may result in a waste of units.

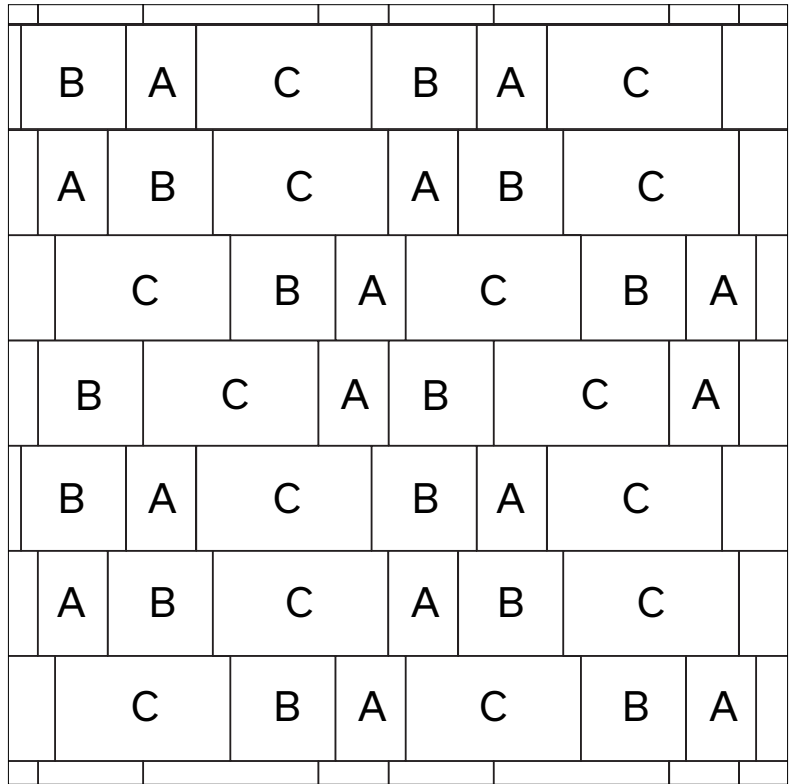

MODULAR LAYING PATTERN

This is only a preview of a modular laying pattern. Replication of this exact pattern may result in a waste of units.

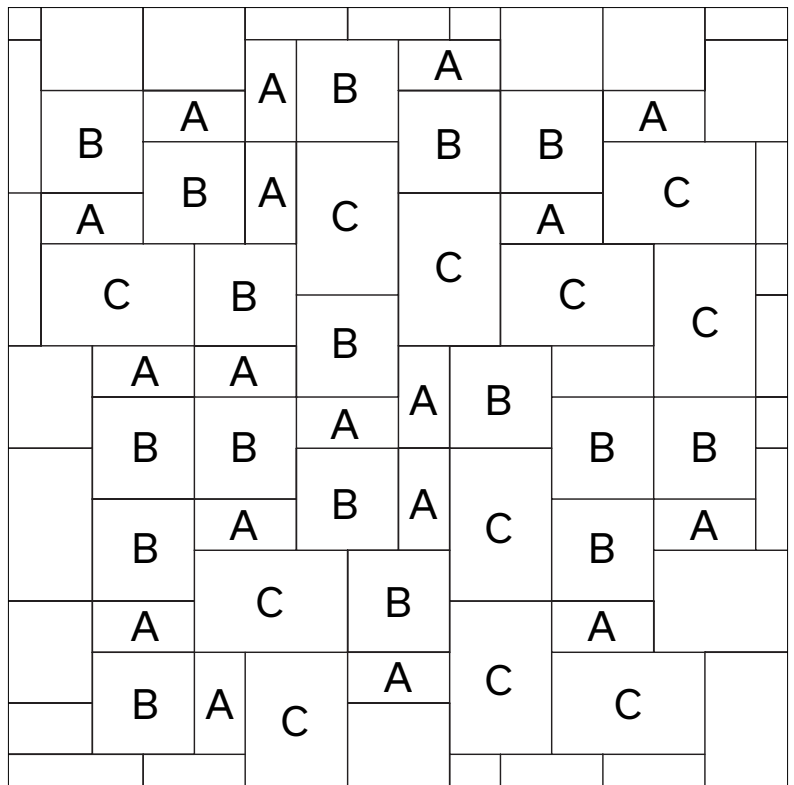

Walls

WALL INSTALLATION

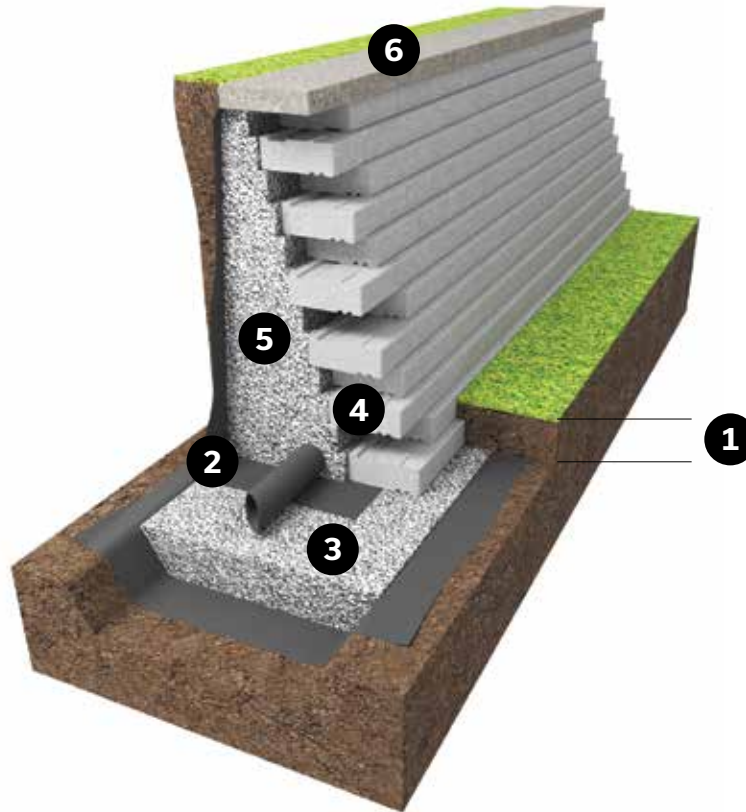

TOOLS REQUIRED

- > 1 wheelbarrow
- > A few pegs
- > 1 plumb line
- > 1 level
- > 1 bricklayer's line 15 m long - 50 ft
- > 1 shovel
- > 1 chalk line
- > 1 measuring tape
- > 1 broom
- > 1 rake
- > 1 guillotine or concrete saw (available from rental stores)
- > 1 vibrating plate or jumping jack (compacting tool available from tool rental stores)

The information contained in these technical documents is supplied for information purposes only. Any application of the information is the sole responsibility of the installer. The installer must ensure that the installation and use of retaining wall projects comply with local regulations and code requirements. A qualified engineer must be consulted for final design for construction purposes. Oldcastle Building Products Canada, Inc. and its affiliates cannot be held responsible for the improper use of information contained in these technical documents.

1 EXCAVATION

Dig a trench. The excavation depth must allow for a granular foundation of a minimum thickness of 150 mm - 6 in., as well as the buried depth of the first rows of units of the wall being built. Also calculate that 10% of the total height of the wall (150 mm or 6 in. minimum) should be buried in the ground. The width of the trench will depend on the type of block selected. You should also leave a space of at least 30 cm - 12 in. at the back of the wall to build a drainage system (see photo #1).

2 PREPARATION OF THE BASE

Cover the rear and bottom of the trench with a geotextile membrane to prevent soil from blocking the drainage system (see illustration section). The membrane should project about 300 mm - 12 in. beyond the top of the slope so it can be folded back on the drainage system when in place. The geotextile membrane can sometimes be placed right behind the wall (to be undertaken following step 4).

3 FOUNDATION

Prepare a 150 mm - 6 in. foundation of 0 to 20 mm - 0 to 3/4 in. stone (see photo #2). In the case of clay soils, we strongly recommend increasing the excavation depth. Compact with a jumping jack or vibrating plate (see photo #3). Level the surface.

4 FIRST ROW

Lay the first row of blocks, level them on the compacted foundation according to your layout (see photo #4). On this foundation, at the back of the wall, install a 100 mm - 4 in. diameter perforated drain and connect it to the existing drainage system. The drain can be wrapped in a geotextile membrane (see photo #5). The drain should be covered with 20 mm - 3/4 in. clean stone or sand during step 5.

5 BACKFILLING THE WALL

Fill in the space behind the wall. The backfill can be composed of 20 mm - 3/4 in. clean stone as shown in the illustration section, or of draining sand (see photo #6). The geotextile membrane must be installed at this stage (behind the wall as shown in photo #6 or at the rear of the trench as in the illustration section).

6 CONSTRUCTION AND COMPLETION

Lay the next rows and backfill the space at the back (step 5) approximately every 200 mm - 8 in. (see photos #7 and #8).

Use capping units to top off the wall if available for your selected type of wall (see photos #9 and #10). We recommend using Techniseal concrete adhesive to secure them.

NOTE:

This guide describes the installation of a standard gravity wall of a given maximum height. (Consult the table of *Wall Characteristics* on page 46 to check the approved height of wall selected). Some walls can be made higher with geogrid reinforcement. Consult a specialized engineer or your Permacon Sales Representative to find out more on the design specifications for your wall.



TYPICAL CROSS-SECTION - SUPPORTING WALL

GRAVITY WALL

- (A) Capping unit
- (B) Wall unit
- (C) 20 mm - 3/4 in. clean stone
- (D) Perforated drain 100 mm - 4 in. Ø connected to services
- (E) Geotextile
- (F) Compacted granular foundation 0 to 20 mm - 0 to 3/4 in. 300 mm - 12 in. minimum
- (G) Buried depth 150 mm - 6 in. minimum

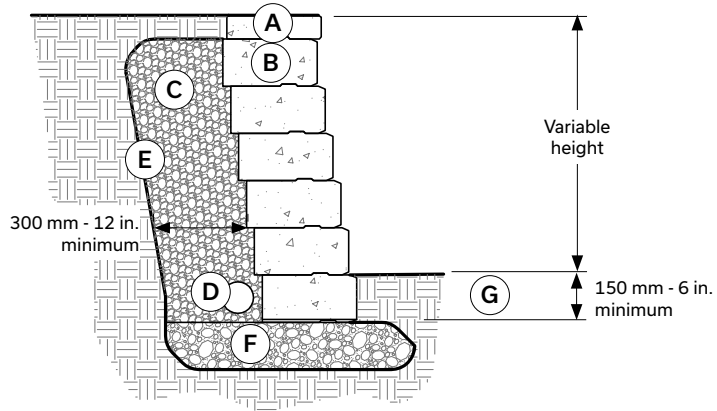

REINFORCED WALL

- (A) Capping unit
- (B) Wall unit
- (C) Typical geogrid (consult your Permacon Sales Representative)
- (D) Compacted reinforced zone, class A sand
- (E) Excavation slope
- (F) Existing soil
- (G) Geotextile
- (H) 20 mm - 3/4 in. clean stone
- (I) Perforated drain 100 mm - 4 in. Ø connected to services
- (J) Compacted granular foundation 0 to 20 mm - 0 to 3/4 in.
- (K) Largest minimum buried depth: 200 mm - 8 in. or $h/10$

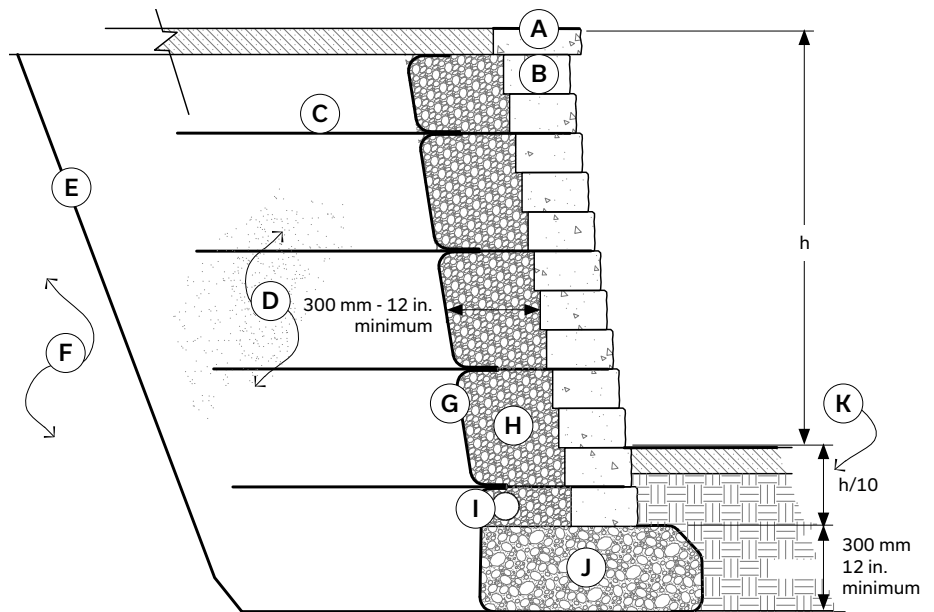

Wall Characteristics

TYPE OF BLOCK	INSTALLATION	MAXIMUM HEIGHT AT THE TOP OF WALL INCLUDING BURIED UNIT WITHOUT OVERLOAD		MINIMUM POSSIBLE RADIUS		WALL ANGLE DEGREE	AMOUNT OF WALL UNITS REQUIRED	
		FT	M	FT	M		/FT ²	/M ²
Tandem System (Lafitt, Melville)	Angled	3.5	1.1	4.0	1.2	9	variable	variable
	Vertical	2.2	0.67	4.0	1.2	0	variable	variable
Celtik® 90 Wall	Angled	3.5	1.1	3.0	0.9	9	variable	variable
	Vertical	2.2	0.67	3.0	0.9	0	variable	variable
Grande Wall (see note)	375, 750, 1125 units	8.5	2.6	65	20	0	5	0.46
	375, 750, 1125 units	10.5	3.2	65	20	9	5	0.46
	375, 750, 1125 units	13.1	4.0	65	20	17	5	0.46
Keystone Wall (see note)	Compact	3.0	0.9	4.0	1.2	0 or 9	22 and/ or 11	2 and/ or 1
Orion Wall	Vertical	2.3	0.72	-	-	0	variable	variable
RB wall	Angled	2.4	0.60	-	-	9.6	3.10	33.40
Split-face Universal* Slope Block Wall	Without joints	5.0	1.5	5.0	1.5	10	35	3.2
	50 mm - 2 in. joints	4.25	1.3	5.0	1.5	10	28	2.6
	100 mm - 4 in. joints	3.7	1.1	5.0	1.5	10	24	2.2
Universal* Slope Wall	Without joints	4.00	1.20	5.0	1.5	15	35	3.2
	50 mm - 2 in. joints	3.25	1.00	5.0	1.5	15	28	2.6
	100 mm - 4 in. joints	2.75	0.80	5.0	1.5	15	24	2.2
Urbano Wall	Angled	2.4	0.72	-	-	3	variable	variable
	Vertical	2	0.60	-	-	0	variable	variable
Vario Wall (90 - 180 mm)	Angled	3.5 - 2.3	1.08 - 0.72	-	-	9.46	variable	variable
	Vertical	2.3 - 1.75	0.72 - 0.54	-	-	0	variable	variable
Wallstone Wall	Angled	16	0.40	-	-	14	3.10	33.40
	Vertical	16	0.40	-	-	0	3.10	33.40
Wedgestone Wall	Angled	16	0.40	2.0	0.6	14	variable	variable
	Vertical	16	0.40	2.0	0.6	0	variable	variable

NOTE: The walls can be installed with other height and overload specifications than those above. Specific designs for special project conditions are available. Consult your Permacon Sales Representative for details.

The information contained in these technical documents is supplied for information purposes only. Any application of the information is the sole responsibility of the installer. The installer must ensure that the installation and use of retaining wall projects comply with local regulations and code requirements. A qualified engineer must be consulted for final design for construction purposes. Oldcastle Building Products Canada, Inc. and its affiliates cannot be held responsible for the improper use of information contained in these technical documents.

Wall Index

Walls

Tandem Next Sytem Wall	48
Tandem System Wall	68
- Building a Double-Sided Wall	79
- Building Stairs	89
- Building Pillars	92
- Outdoor Living Components	102
Celtik Plus 90 Wall	131
Grande Wall	136
Orion Wall	185
RB Wall	191
Universal Slope Block Wall	193
Urbano Wall	194
Vario Wall	210
Wallstone and Wedgestone Walls	266
Wall Installation Guidelines Wall	270
Keystone Wall	272

PACKAGING

For product packaging information, please refer to our Product Data Guide on our website.



English
Quebec



English
Ontario



The information contained in these technical documents is supplied for information purposes only. Any application of the information is the sole responsibility of the installer. The installer must ensure that the installation and use of retaining wall projects comply with local regulations and code requirements. A qualified engineer must be consulted for final design for construction purposes. Oldcastle Building Products Canada, Inc. and its affiliates cannot be held responsible for the improper use of information contained in these technical documents.

Tandem[®] Next System

SYSTEM ELEMENTS

TANDEM NEXT STRUCTURAL UNIT 180 mm

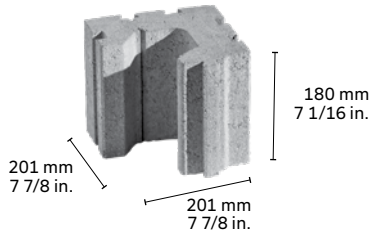

STARTER UNIT

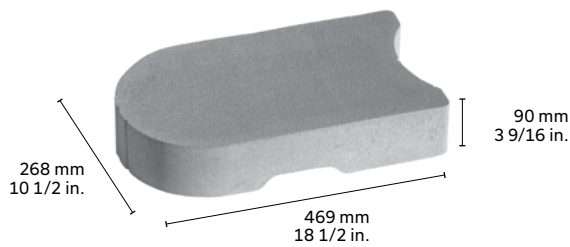

TANDEM NEXT UNIVERSAL CONNECTOR



MELVILLE PLUS 60 CAPPING UNIT

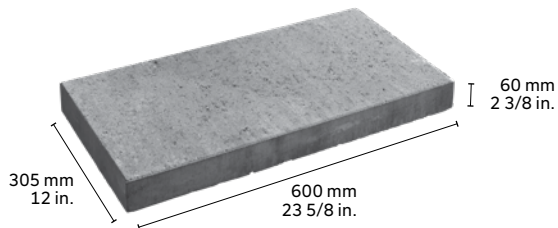

MELVILLE PLUS 90 CAPPING UNIT

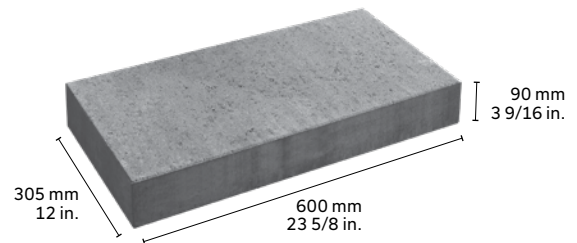

MELVILLE PLUS STEP UNIT (FOR DOUBLE-SIDED WALL CAPPING)

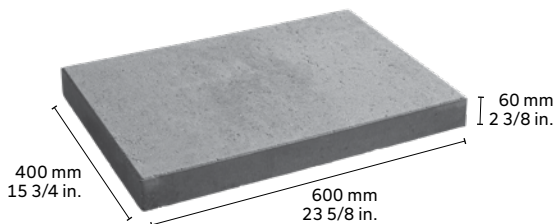

SYSTEM ELEMENTS (CONT'D)

LAFITT TANDEM VENEER UNITS 180 mm

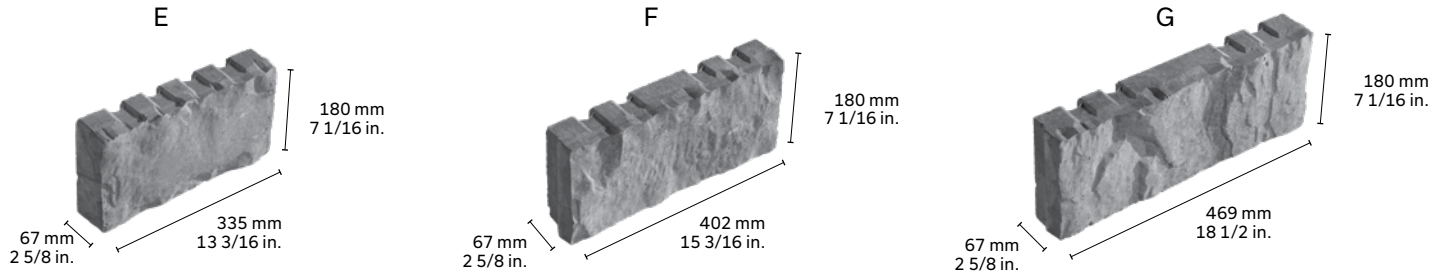

MELVILLE TANDEM VENEER UNITS 180 mm

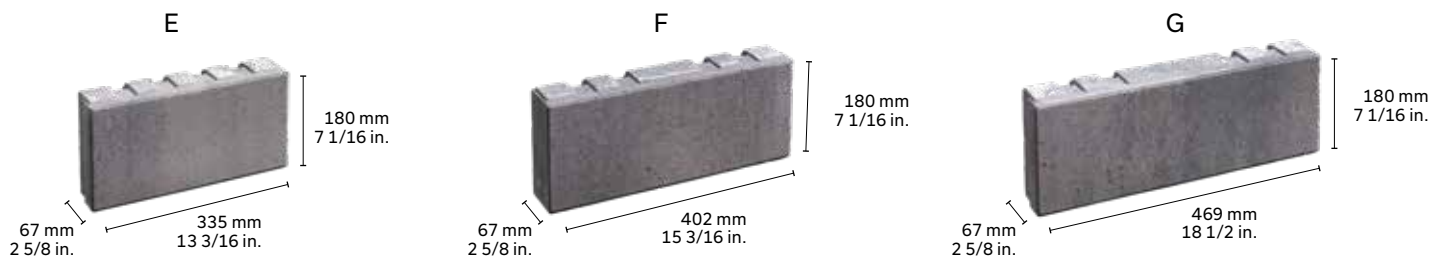

DESCRIPTION

The new Tandem Next 180 mm wall system allows the creation of retaining walls, double-sided walls, columns and stairs.

It applies the principle of interlocking a veneer unit into a structural unit with a dovetail joint (tenon and mortise or interlocking male/female system). Each structural unit has a vertical tenon (male side) and each veneer unit has at least two mortises (female side). The veneer units are joined to the structural units by simply sliding their tenon into the mortises to form the Tandem Next units.

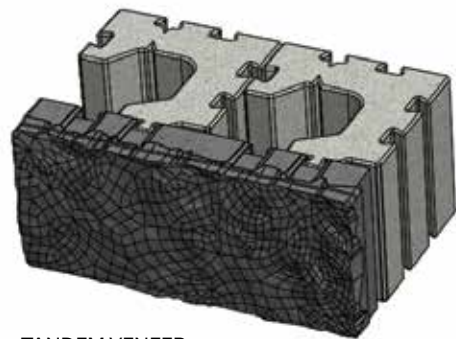

TANDEM VENEER
(LAFITT, MELVILLE)

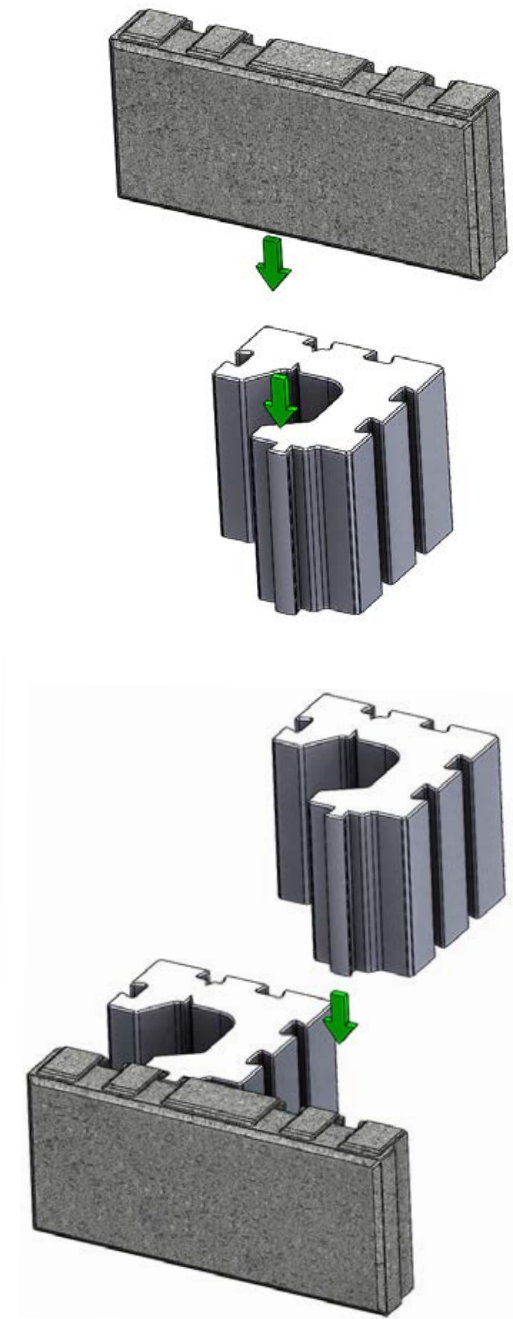

ASSEMBLY

Assembly of Tandem Next elements always requires the use of two structural units for one veneer unit, Melville and Lafitt Tandem. The structural units obviously must be positioned so that the tenons are always located behind a veneer unit.

MURET TANDEM NEXT AVEC VENEERS TANDEM SYSTEM (LAFITT, MELVILLE)

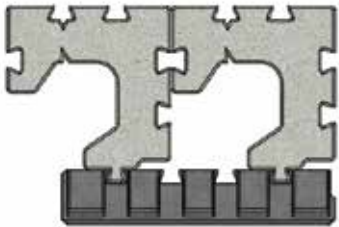

VENEER E

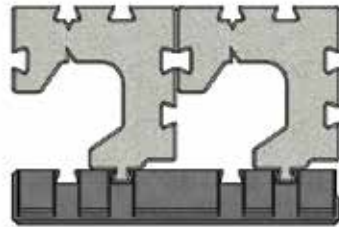

VENEER F

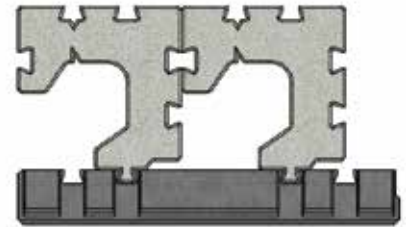

VENEER G

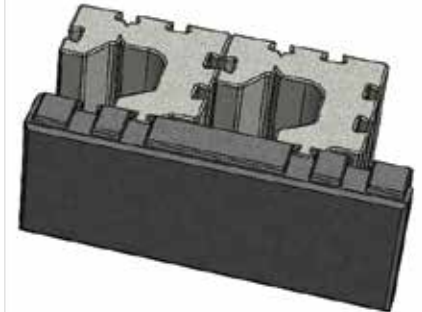
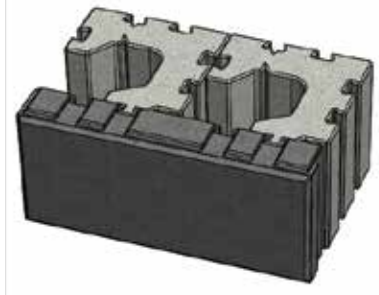
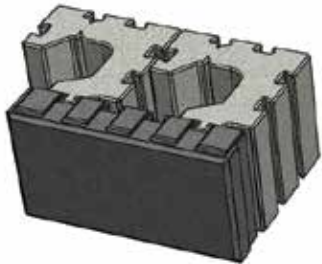

The structural units are reversible and the back can be oriented to the left or right depending on the veneer format used. It is recommended to place the structural units in the mortises farthest from a veneer whenever possible.

SETBACK WALL

The Tandem Next wall system allows construction of vertical or sloped walls using the universal connector specially designed for this purpose. This connector is inserted in one of the two grooves located on the back of the structural units. The connectors are slid from the top of the grooves until they overlap the structure unit located below by a few centimetres. In general, one universal anchor is required for each structural unit.

To build a sloped wall, the connector must be placed as shown in the drawing. Simply push the Tandem Next unit forward until the connector locks it. This will form a setback of about 9 mm relative to the lower unit.

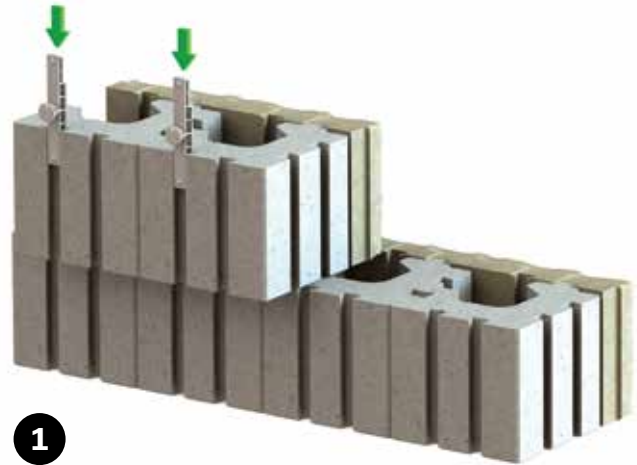

1

Slide the universal connector as follows (one connector per unit)

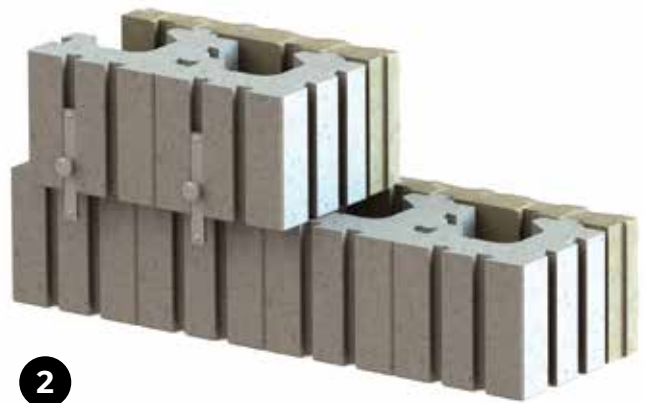
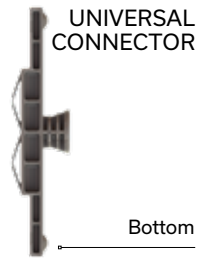

2

Exceed the lower part of the connector with the unit underneath

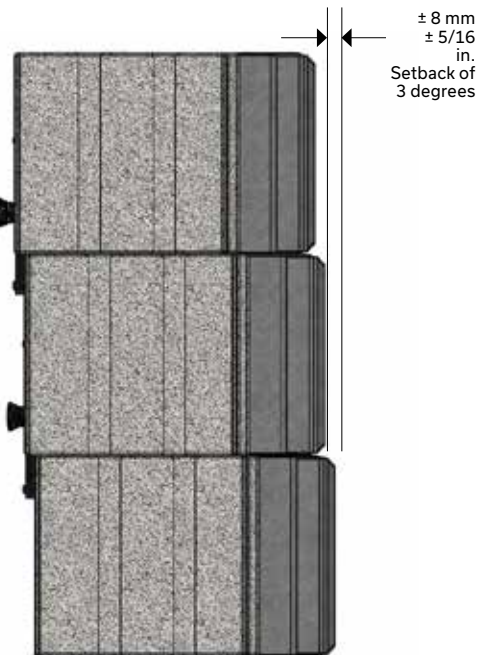

CROSS-SECTIONAL VIEW



3

Push the unit forward until it locks

VERTICAL WALL

A vertical wall applies the same principle as a sloped wall, with the difference that the universal connector is simply turned 180 degrees (see the drawing). After insertion in a groove as far as the overlap with the unit underneath, the connector slopes slightly relative to the vertical. The Tandem Next unit then is pushed forward until it locks, to create a vertical wall.

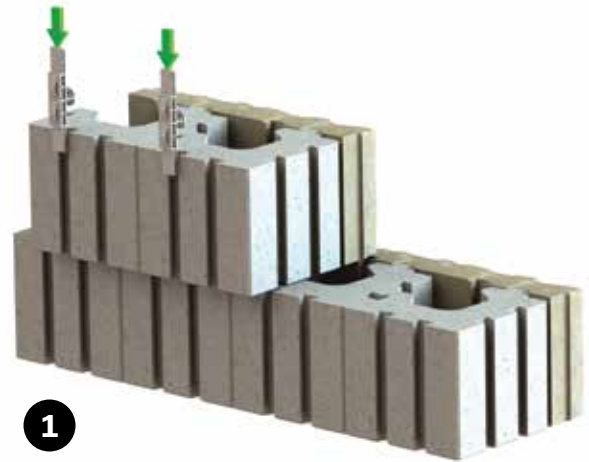
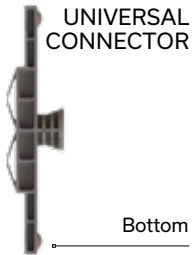

1
Slide the universal connector as follows (one connector per unit)



2
Exceed the lower part of the connector with the unit underneath

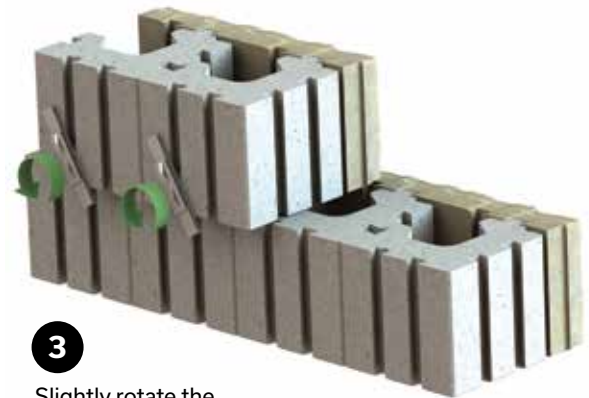

3
Slightly rotate the universal connector

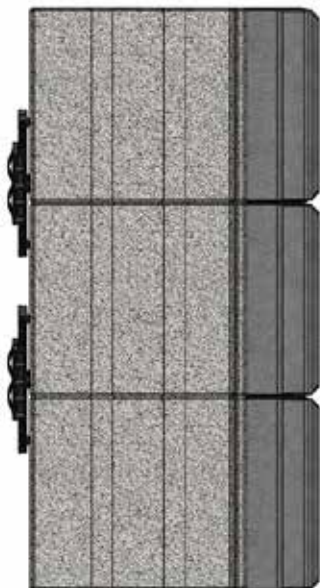

CROSS-SECTIONAL VIEW



4
Push the unit forward until it locks

WALL MORE RESISTANT TO LOADS

The maximum above-ground height of a Tandem Next retaining wall is 900 mm - 36 in. for a sloped wall and 560 mm - 22 in. for a vertical wall. A portion of the wall at least 150 mm - 6 in. high must be buried in the ground to ensure its stability.

The flexibility of the Tandem Next system allows interconnection of structural units by using Tandem Next universal connectors. This has the advantage of being able to build stronger walls by adding units in the back.

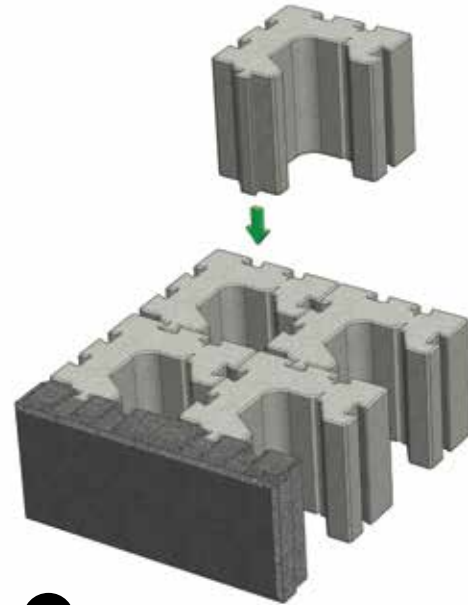

1

Install an additional structural unit by sliding the vertical tenon (male side) in the mortise (female side)

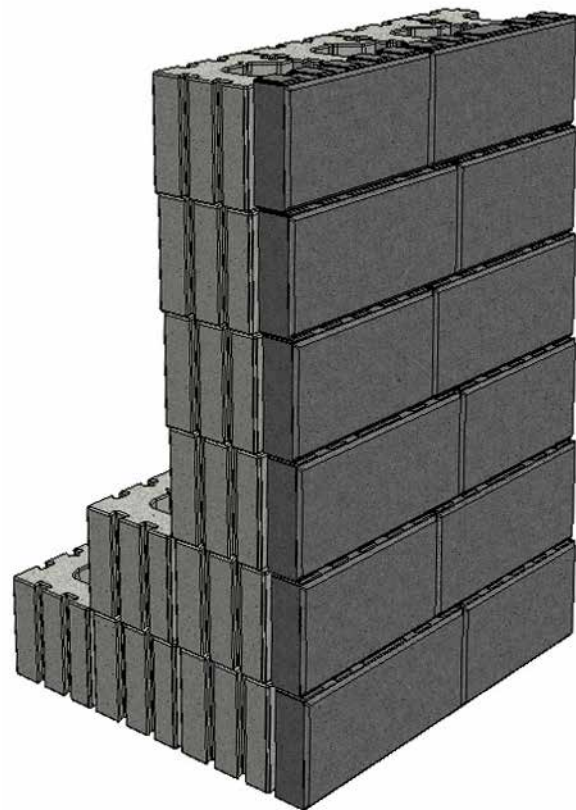
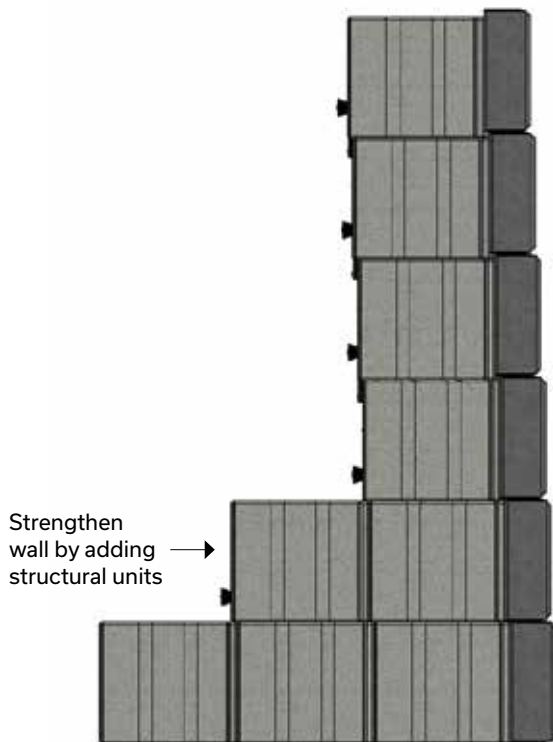

REINFORCING WALLS (CONT'D)

SLOPED TANDEM NEXT WALL

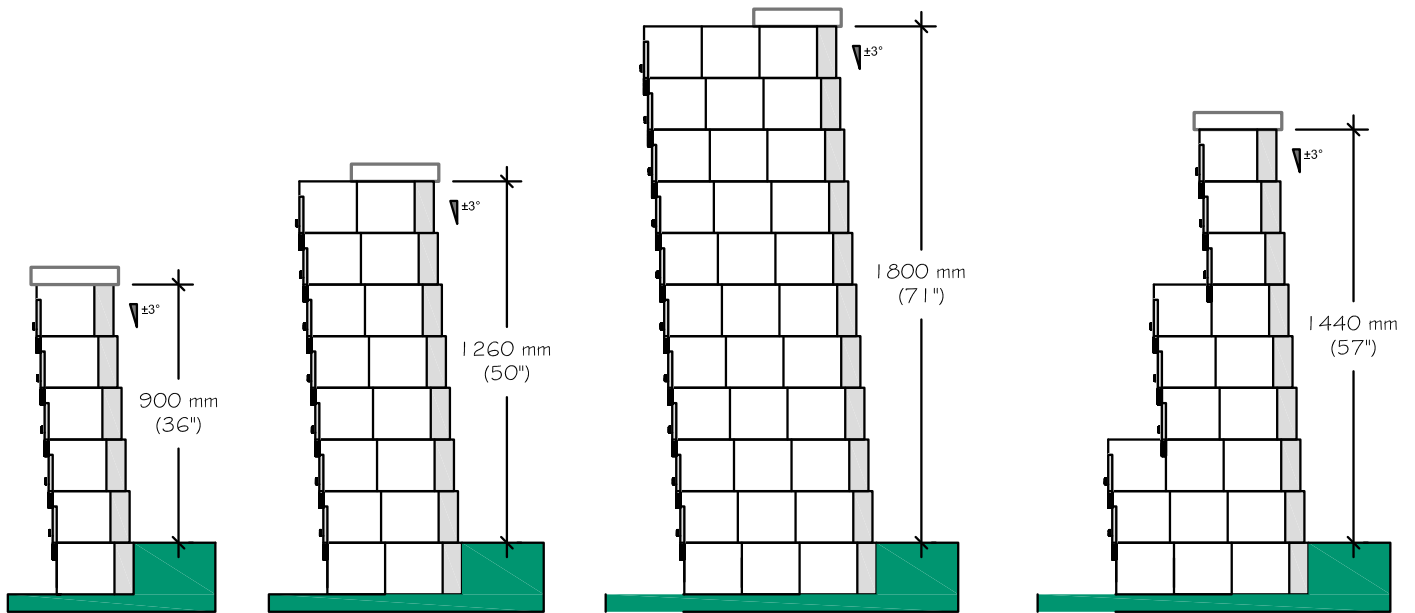

VERTICAL TANDEM NEXT WALL

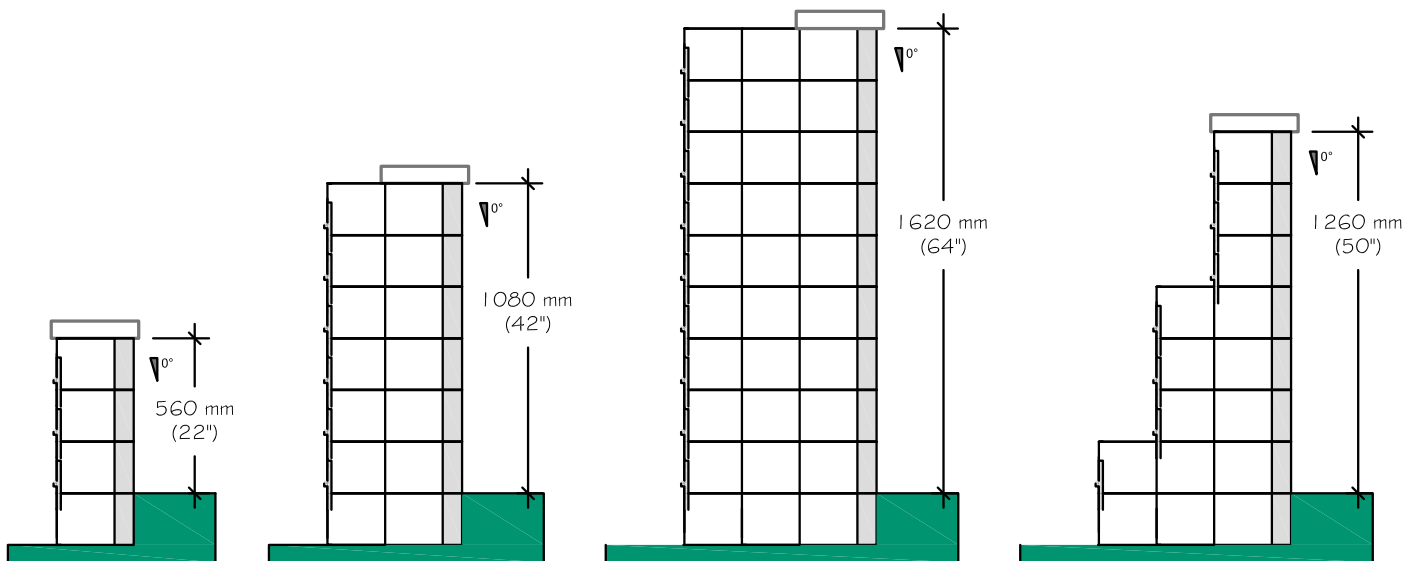

CROSS-SECTION - TANDEM NEXT RETAINING WALL WITH INCLINATION

Here we present the general typical construction cross-section of a Tandem Next wall. The width of a Tandem Next retaining wall is 268 mm - 10 1/2 in.

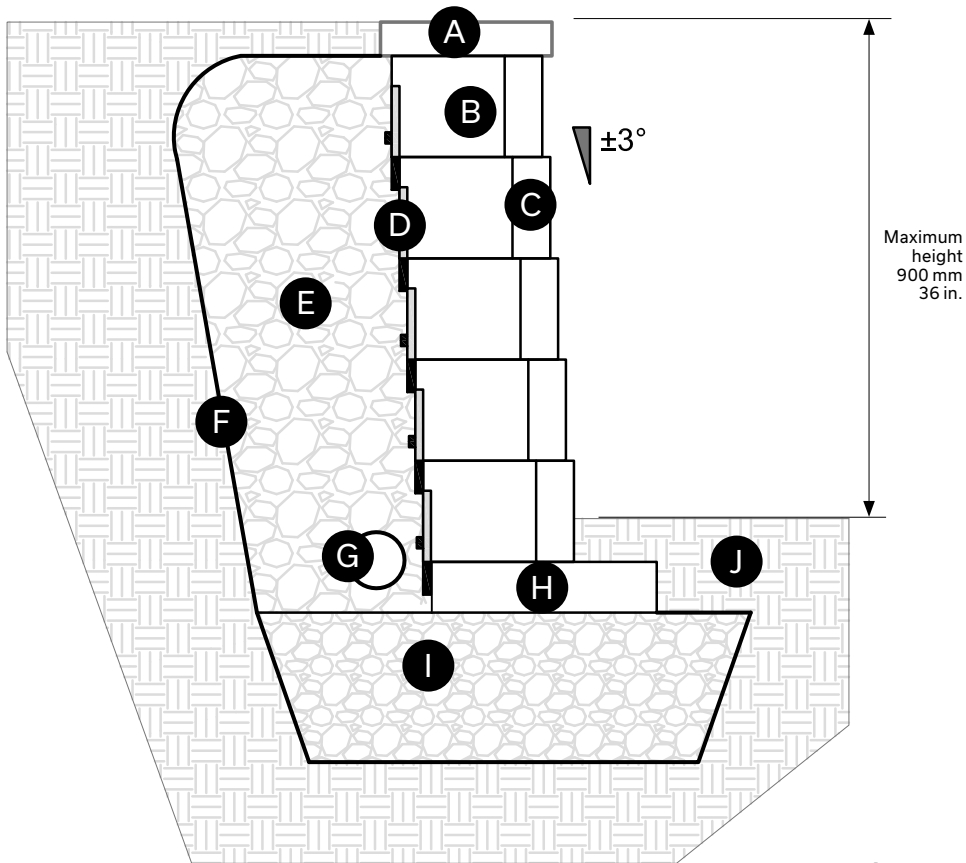

- A** Melville Plus capping unit (or other)
60 x 305 x 600 mm - 2 3/8 x 12 x 23 5/8 in.
- B** Tandem Next wal structural unit
180 x 201 x 201 mm - with 20 mm - 3/4 in.
clear crushed stone
- C** 180 mm veneer unit (Tandem System)
- D** Tandem Next universal connector
- E** 20 mm - 3/4po clear stone 300 mm
minimum
- F** Geotextile membrane
- G** Perforated drain 100 mm - 4 in. Ø
connected to services
- H** Starter unit 90 x 268 x 469 mm -
3 1/2 x 10 1/2 x 18 1/2 in.
- I** 0 to 20 mm - 0 to 3/4 in. compacted granular
foundation 300 mm - 12 in. minimum
- J** Minimum buried depth 150 mm - 6 in.

LAYING PATTERN

LINEAR PATTERN
100% Tandem 180

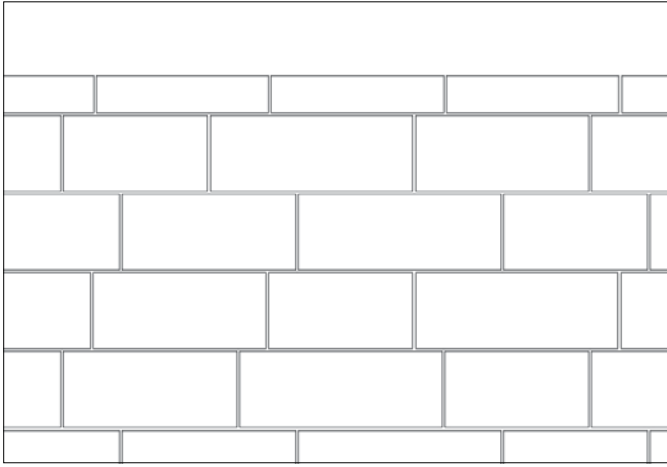

CONSTRUCTION OF A RETAINING WALL

STRAIGHT WALL

The construction of a Tandem Next wall begins with the placement of the starter units installed side by side (the longest side).

Install a first row of structural units at random on the starter units, using all the formats in equal proportions and following the indications for the typical cross-section. Then insert the veneer units in the structural units as described previously, and provide for the placement of the universal connectors depending on the chosen slope of the wall. The next rows are installed in the same way, avoiding alignment of the vertical joints of one row to another.

Clean stone must be installed behind the structural units. It is also recommended to install clean stone **in the empty spaces** of the structural units.

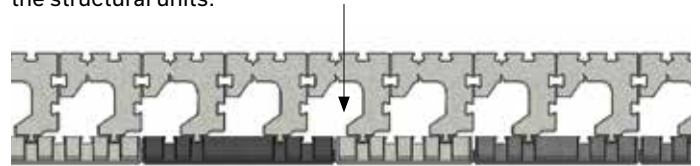

Melville and Lafitt Tandem

CURVED WALL

The construction of a Tandem Next curved wall begins with the placement of the starter units installed side by side (the longest side), bevelling the units to form the required curve.

Building a concave or convex curved walls is possible with the Tandem Next system. The use of smaller veneer units allows reduction of the bending radius. The back part of the structural units sometimes must be cut as illustrated to create the bevelled elements necessary for the construction of curved walls. The minimum bending radius of a Tandem Next wall is 2.4 m - 8 ft.

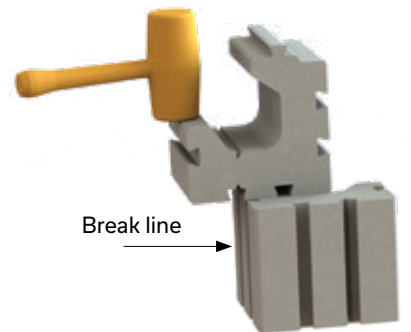
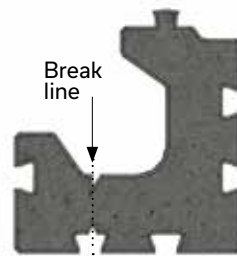

To close a concave curve, break the end of the unit with a hammer

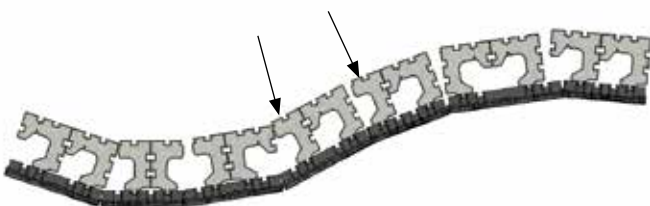

CONSTRUCTION OF A RETAINING WALL (CONT'D)

BUILDING A 90° OUTER CORNER

It is recommended to always begin a wall with a corner. A 90° outer corner is produced by using the veneers specially designed for this purpose, depending on the chosen type of veneer. The veneer units all contain integrated corners, but in different proportions depending on the chosen type of veneer.

A Lafitt Tandem 180 veneer cube contains 8 units with one 90° corner side per row. All the Melville Tandem 180 veneer units contain one corner side.

Stacking position on pallets (with a textured end)

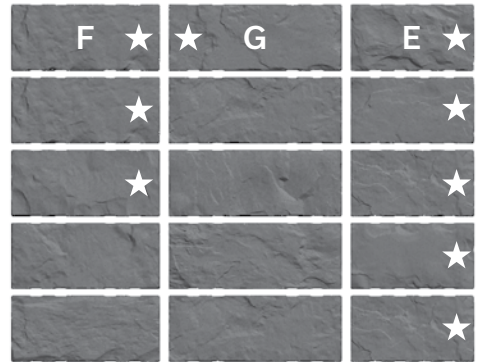

LAFITT TANDEM - 180 MM UNITS

90° CORNER WALL PRINCIPLE

The veneer units are reversible to form left or right corners. For each row, the veneer that forms the corner is affixed to the structural unit using a Tandem Next universal anchor. The position of the veneer is alternated 90° from one row to the next. We recommend gluing the elements used to make the corner of each row, using concrete adhesive. Spread the adhesive on the veneer units or the structural units or both. Only one universal anchor per row is required to form a corner. Long veneers must be affixed to the structural unit following the corner (tenons and mortise).

It is possible to add other structural units in the corners of a wall to strengthen it, if required.

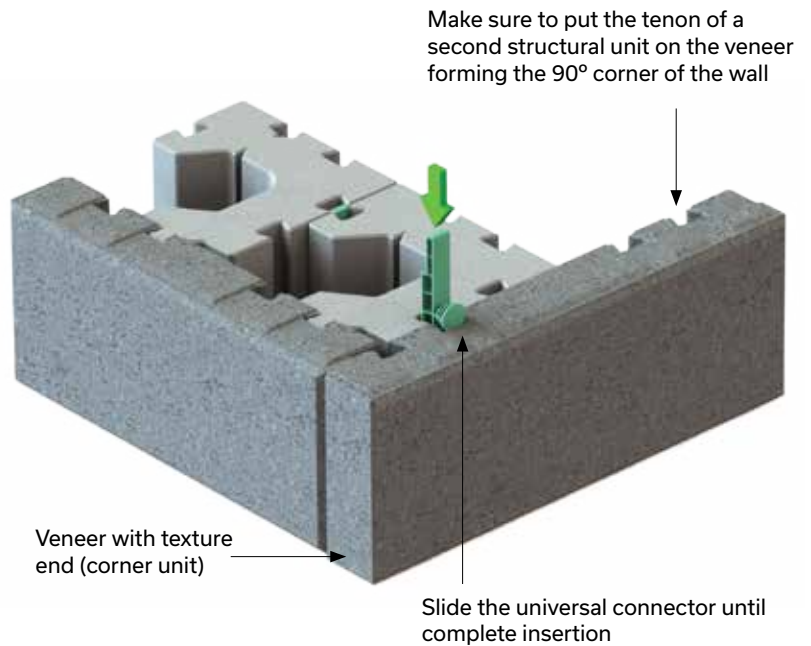

CONSTRUCTION OF A RETAINING WALL (CONT'D)

BUILDING AN OUTER 90° CORNER WITH TANDEM VENEER (MELVILLE, LAFITT)

Always use veneers with texture end (corner unit) to build a corner

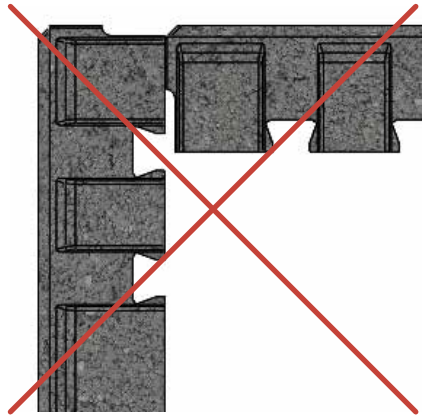
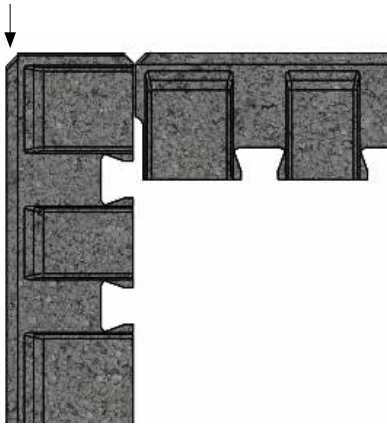

Make sure to put the tenon of a second structural unit on the veneer forming the corner of the wall

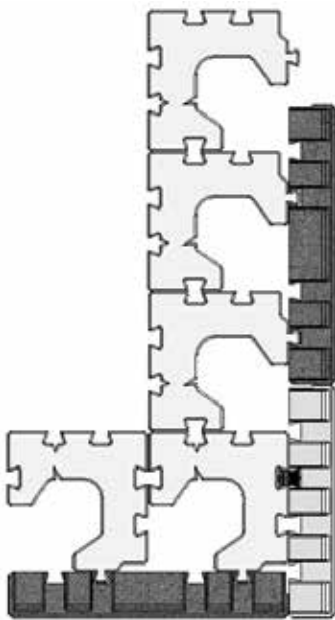

WITH VENEER E

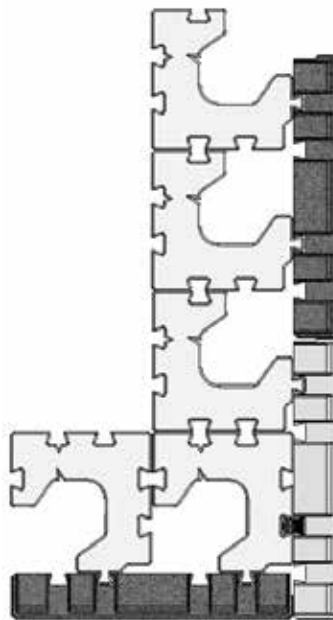

WITH VENEER F

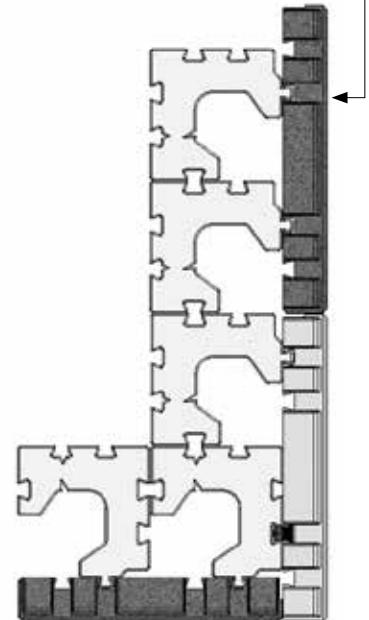

WITH VENEER G

CONSTRUCTION OF A RETAINING WALL (CONT'D)**BUILDING A 90° INNER CORNER**

Building an inner corner is based on the principle illustrated opposite. The solidity of an inner corner is assured by the placement of a structural unit forming the back corner of the wall. This additional unit is anchored to the others with a Tandem Next universal connector.

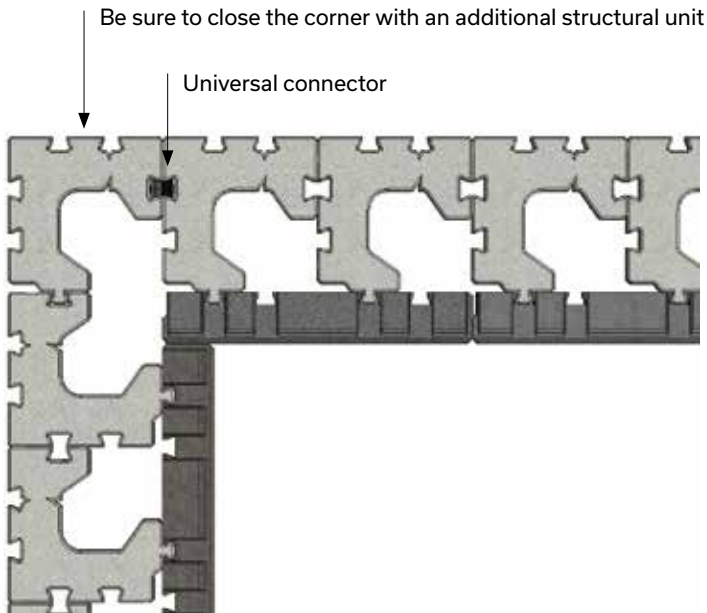

MELVILLE AND LAFITT TANDEM VENEER

TANDEM NEXT RETAINING WALL CAPPING

Tandem Next retaining walls can be capped with different types of products:

- > Melville Plus 60 capping unit
- > Lafitt Plus 90 capping unit
- > Celtik Plus Straight 90 capping unit

The capping units must be glued to the last row of units, using an appropriate concrete adhesive. For the curved parts, certain elements must be bevelled to follow the curve of the wall.

TANDEM NEXT DOUBLE-SIDED WALL

A double-sided wall is built without a slope and thus is vertical. Installation of a Tandem Next double-sided wall requires the use of veneer units, which are affixed to each side of the Tandem Next structural units. The basic principle is to build a Tandem Next wall and add veneer units in the back, affixing them with Tandem Next universal connectors in the vertical

position. The outer corners of a double-sided wall must be built by using corner veneer units. The flexibility of the Tandem Next system is based on the fact that the structural units can be positioned in several ways, ensuring that each veneer can be affixed to them by tenons or by universal connectors.

TANDEM NEXT DOUBLE-SIDED WALL WITH TANDEM VENEER (MELVILLE, LAFITT)

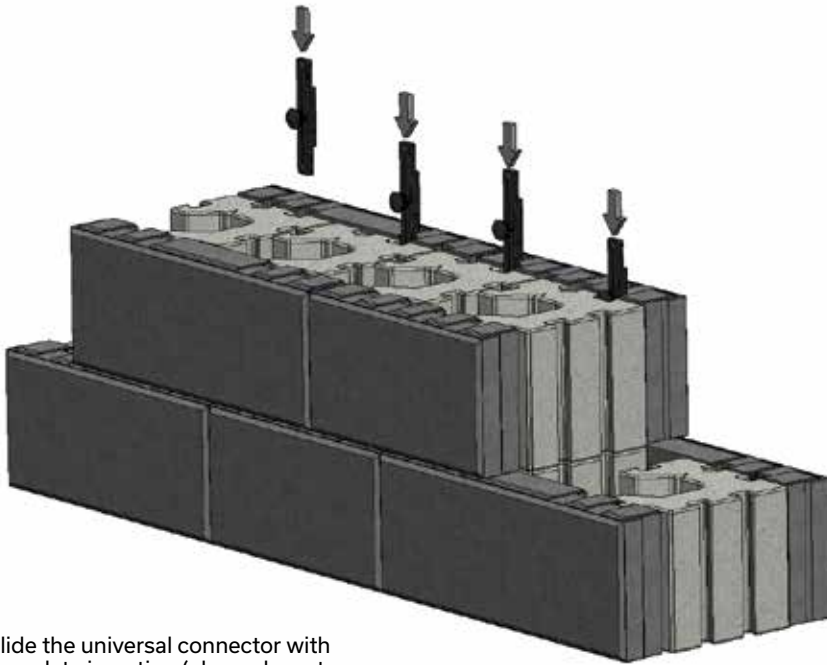

Slide the universal connector with complete insertion (always have two connectors per veneer)

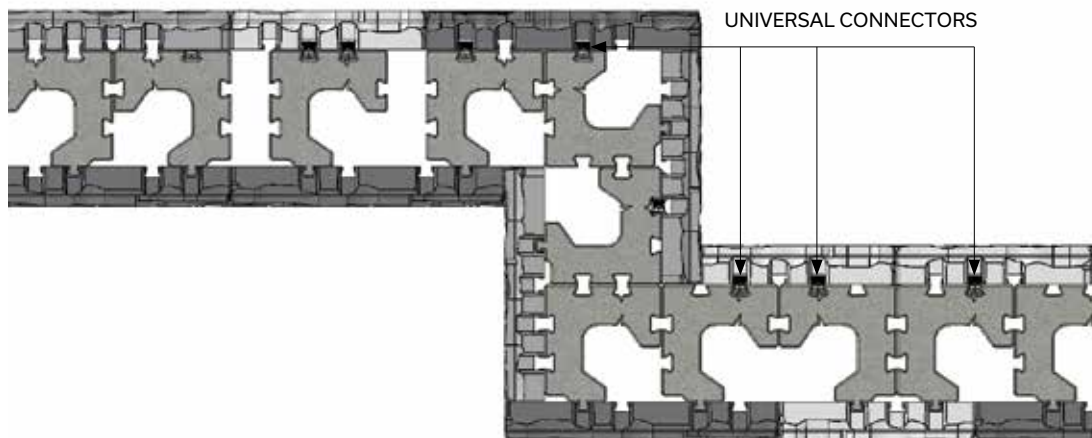

CROSS-SECTION - TANDEM NEXT DOUBLE-SIDED WALL

A typical cross-section of a double-sided wall is shown here. A Tandem Next double-sided wall rests on a first base course made with starter units installed side by side (the longest side). The units are placed at random, avoiding alignment of

the vertical joints of one row to another. It is essential to glue each row together (including the base course), using concrete adhesive. Spread the adhesive on the veneer units or the structural units or both.

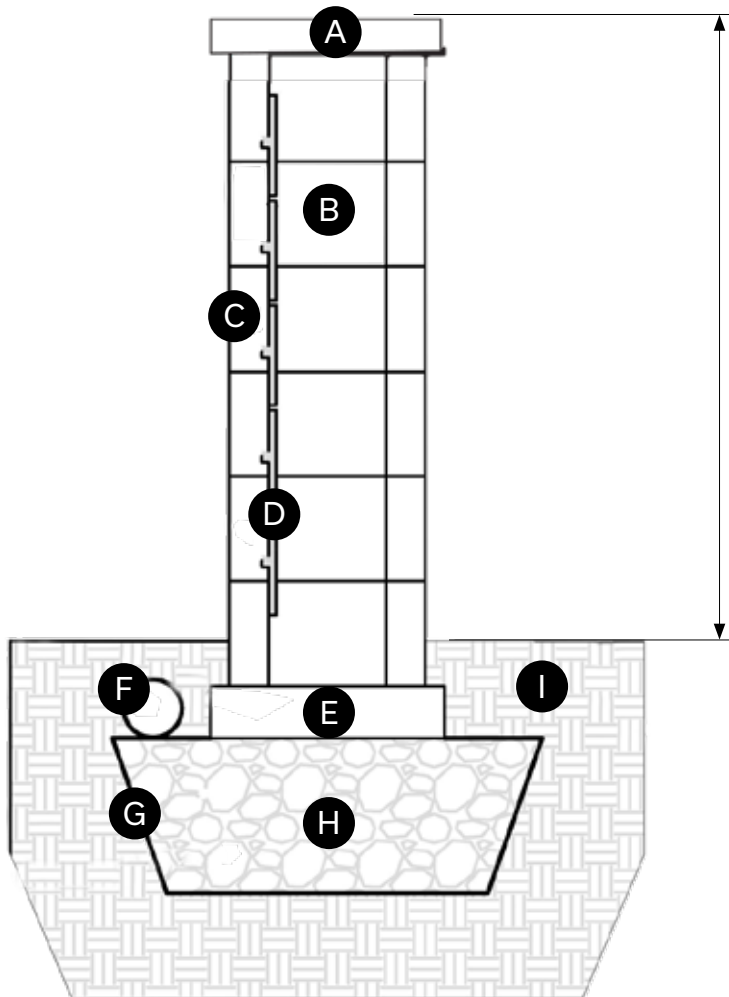

Maximum height
1067 mm
42 in.

- **A** Melville Plus wall step unit
60 x 400 x 600 mm - 2 3/8 x 15 3/4 x 23 5/8 in.
- **B** Tandem Next wall structural unit
180 x 201 x 201 mm with clear crushed stone
20 mm - 3/4 in.
- **C** 180 mm veneer unit (Tandem System)
- **D** Universal connector Tandem Next
- **E** Starter unit 90 x 268 x 469 mm -
3 1/2 x 10 1/2 x 18 1/2 in.
- **F** 100 mm Ø - 4 in. perforated drain pipe
connected to sewer services
- **G** Geotextile membrane
- **H** 0 to 20 mm - 0 to 3/4 in. compacted granular
foundation 300 mm - 12 in. minimum
- **I** Minimum buried depth 150 mm - 6 in.

TANDEM NEXT DOUBLE-SIDED WALL END

The construction details of a double-sided wall end are shown here. The veneer units must be cut to 268 mm - 10 1/2 in. to allow their installation. Only the smallest veneer unit must be used to finish a double-sided wall (unit A Tandem Next and unit E for Tandem veneers). It will be necessary to use two universal anchors to affix these elements. It is suggested to use concrete adhesive to glue together the elements forming the end of a wall, at each row.

The width of a Tandem Next double-sided wall is 335 mm - 13 3/16 in. and its maximum above-ground height is 1067 mm - 42 in.

DOUBLE-SIDED TANDEM NEXT WALL CAPPING
 Tandem Next double-sided walls can be capped with different types of products: Melville Plus 60 step and Melville Plus 90 step.

END OF WALL WITH TANDEM SYSTEM

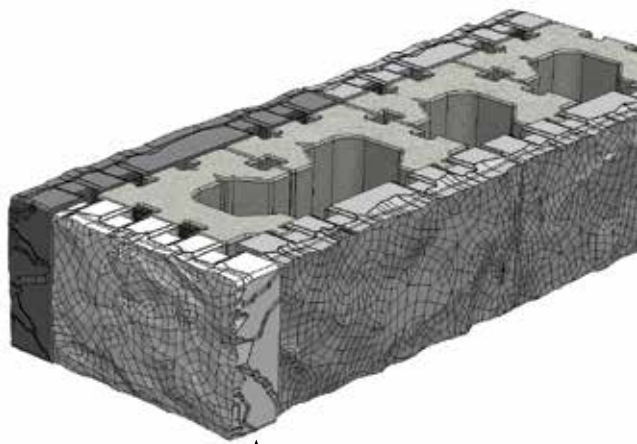

↑ Veneer with texture at the end (corner unit)

End of wall with veneers E and F

VENEER E ↓

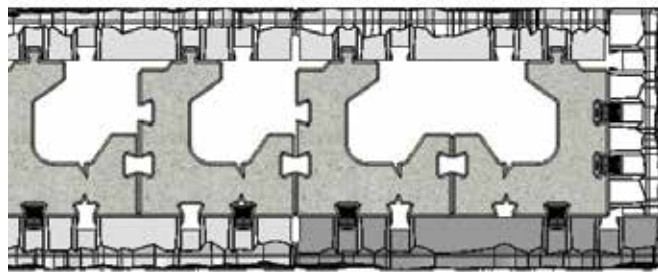

↑ VENEER F

End of wall with veneers F and G

VENEER F ↓

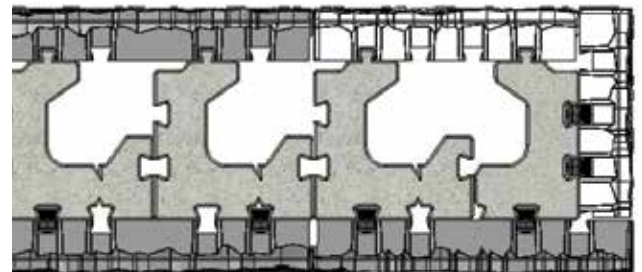

↑ VENEER G

TANDEM NEXT COLUMN

Columns can be built with the Tandem Next system. The veneer units are secured to the structural units with their tenon and with universal connectors. It is possible to create a space in the centre of the column so that a post can be inserted. However, this post must not be structural (for example, the post can serve as a lamppost).

Four column formats are possible:

- > 402 x 402 mm - 15 7/8 x 15 7/8 in.
- > 469 x 469 mm - 18 1/2 x 18 1/2 in.
- > 536 x 536 mm - 21 1/4 x 21 1/4 in.

A Tandem Next doubled-sided wall rests on a first base course made with starter units. We propose five types of construction of columns in different formats. This type of construction requires the creation of 90° corners. The position of the veneer is alternated by 90° from one row to another. It is essential to glue each row together (including the base course), using concrete adhesive. Spread the adhesive on the veneer units or the structural units or both. The construction of Tandem Next columns will require that only units with the same format be used. This will leave surpluses in the other formats on the same pallet.

The smallest column formats require cutting of the structural units (see drawings). To increase the overall solidity of a column, it is possible to install universal connectors at the centre of a column 536 x 536 mm (21 x 21 in.) that joins the four structural units. The empty spaces at the centre of the column must be filled with clean stone. The maximum height of a column is limited to 1080 mm - 42 1/2 in., which includes a portion buried in the ground of at least 150 mm - 6 in.

NOTE: We recommend using only Melville Tandem veneers to build columns.

MELVILLE TANDEM NEXT VENEER COLUMN

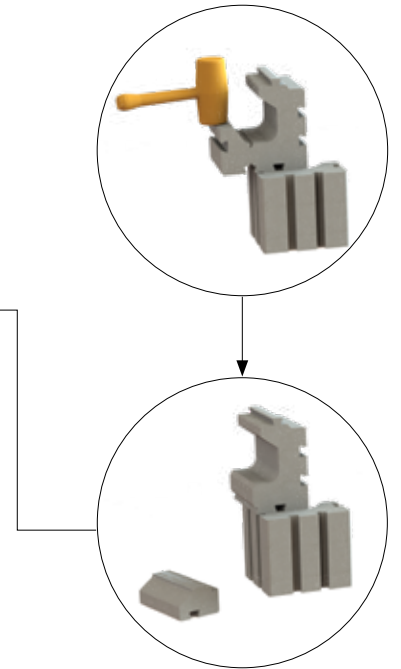
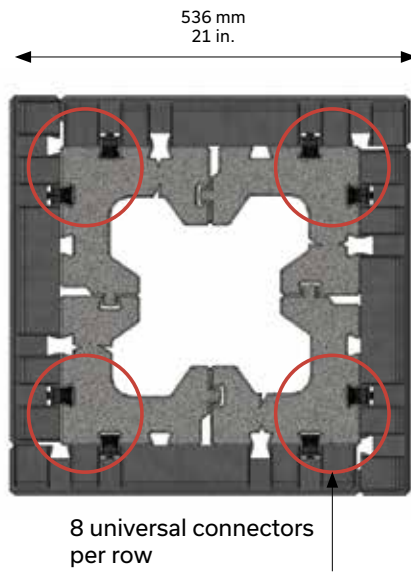
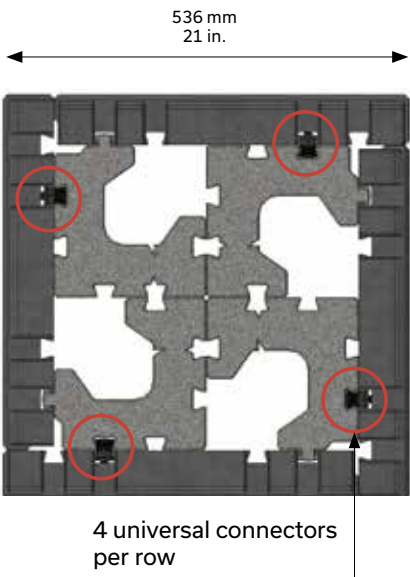
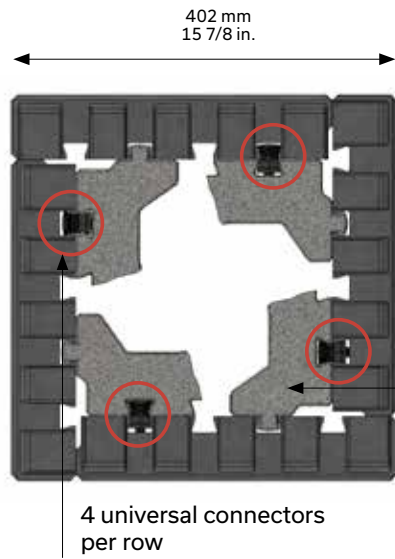
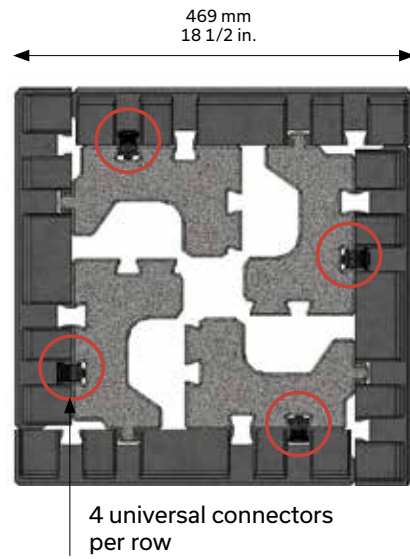

NOTE: The structural units can be joined with additional universal anchors in the centre to increase the strength of the column.

BUILDING OF STAIRS

The Tandem Next system allows the building of stairs. The construction of Tandem Next landings at each level of the stairs ensure maximum stability of the entire structure. We show the basic principles here.

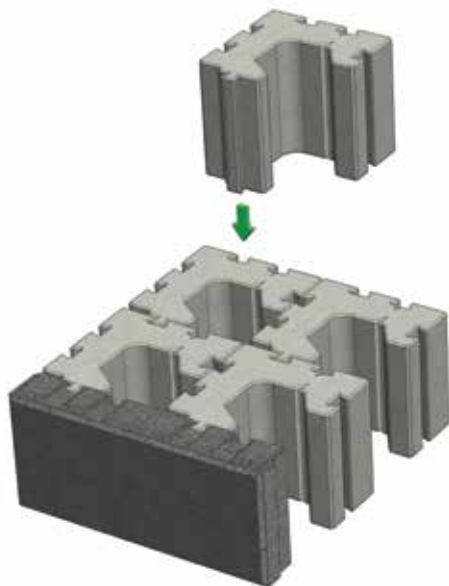

Install an additional structural unit by sliding the vertical tenon (male side) into the mortise (female side)

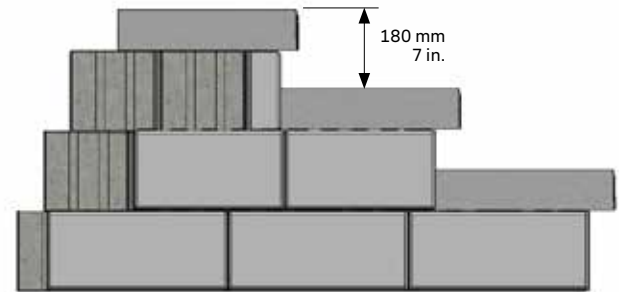

SIDE VIEW

A first landing is installed with the structural units attached together with universal connectors. The size of this landing varies with the number of stairs to be constructed. The veneer units are then placed all around and secured with universal anchors. A second landing is constructed above according to the same procedure by installing a series of stairs in front, secured with concrete adhesive. Construction continues until the last stair. The Tandem Next System stairs can be produced using different products: Melville Plus 60 step, Melville Plus 90 step and Lafitt Plus 90 step.

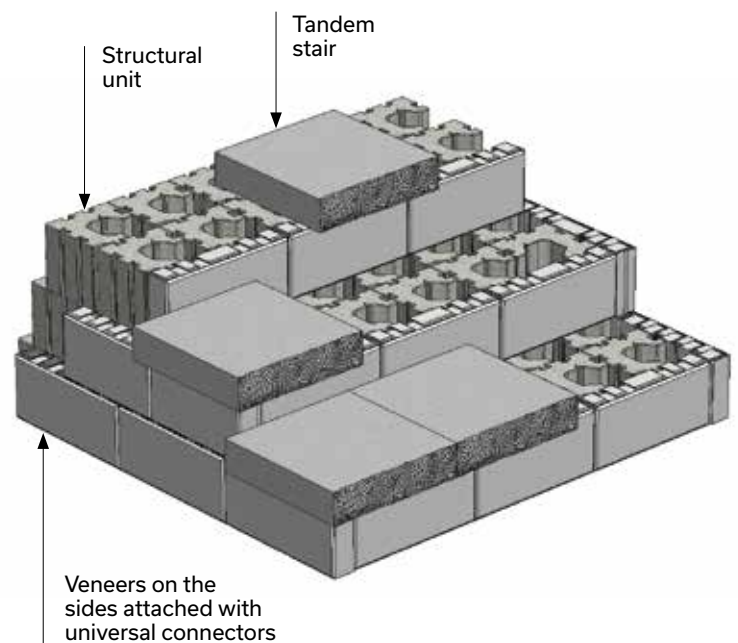

Tandem System®

SYSTEM ELEMENTS

90 MM VENEER UNITS

STRUCTURAL

Height: 90 mm - 3 9/16 in.
Depth: 155 mm - 6 1/8 in.

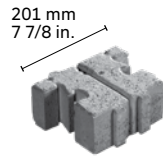

A

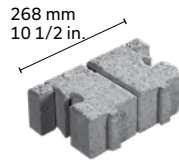

B

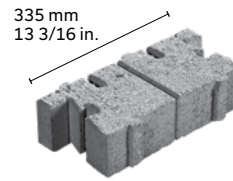

C

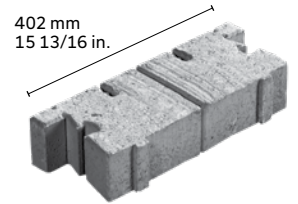

D

LAFITT

Height: 90 mm - 3 9/16 in.
Depth: 67 mm - 2 5/8 in.



A

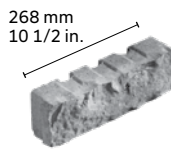

B

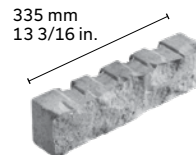

C

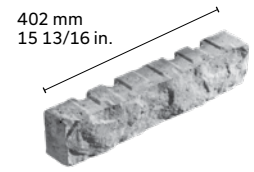

D

MELVILLE

Height: 90 mm - 3 9/16 in.
Depth: 67 mm - 2 5/8 in.



A



B



C



D

180 MM VENEER UNITS

LAFITT

Height: 180 mm - 7 1/16 in.
Depth: 67 mm - 2 5/8 in.

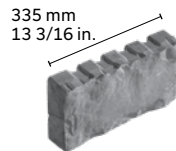

E

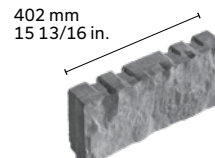

F

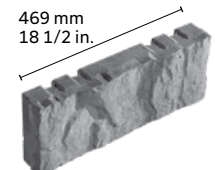

G

MELVILLE

Height: 180 mm - 7 1/16 in.
Depth: 67 mm - 2 5/8 in.



E



F



G

SYSTEM ELEMENTS

OTHER UNITS (SOLD SEPERATELY)

LAFITT PLUS STRAIGHT CAPPING

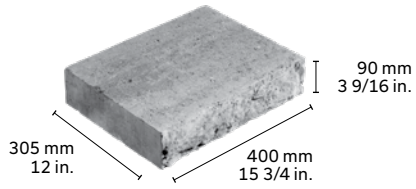

LAFITT PLUS STEP

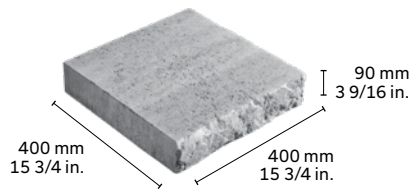

MARCHE MELVILLE PLUS 90

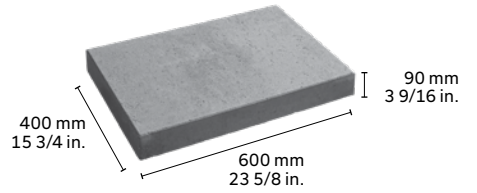

MELVILLE PLUS STRAIGHT CAPPING

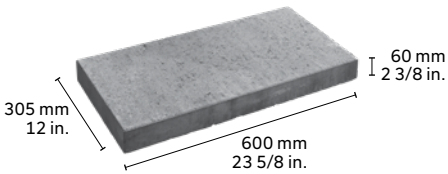

MELVILLE PLUS 60 STEP

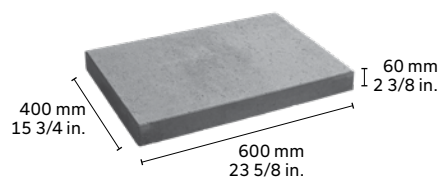

STARTER UNIT

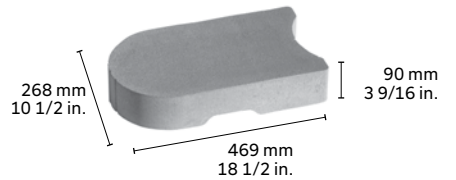

ANCHORS AND CONNECTORS

SETBACK ANCHOR



DOUBLE-SIDED CONNECTOR



CORNER ANCHOR



TANDEM GRID CONNECTOR



OTHERS

TANDEM GRID PILLAR KIT

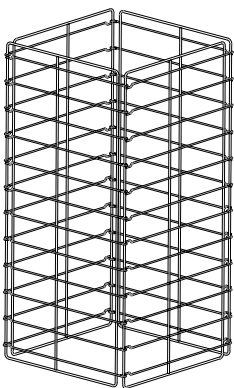

TANDEM MODULAR GRID

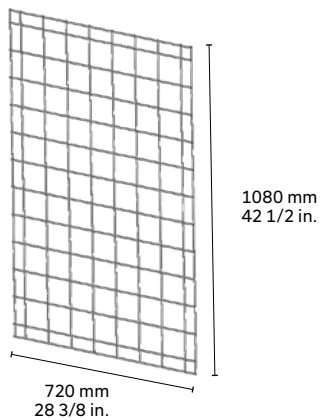

TANDEM SHELF ANGLE

64 x 64 x 2439 mm
2 1/2 x 2 1/2 x 8 in.



Each Tandem Grid Pillar Kit comes with 1 bag of 200 Tandem grid connectors.

Each Tandem Modular Grid comes with 1 bag of 60 Tandem grid connectors, 10 screws #10 x 1 1/4 in. and 10 loop clamps.

UNIT ASSEMBLY



TANDEM 90

Tandem 90 units are 3 9/16 in. (height). For each structural unit, there is a veneer unit of the same length and height. The unit can be assembled using the dovetail joint (an interlocking male/ female system). Each structural unit has two vertical tenons (male side) and each veneer unit has at least two mortises (female side). The veneer units are joined to the structural units by simply sliding the mortises into the tenons to create the Tandem unit. There are two types of veneer units, Lafitt and Melville Tandem units. The total depth of the unit is 222 mm - 8 3/4 in.

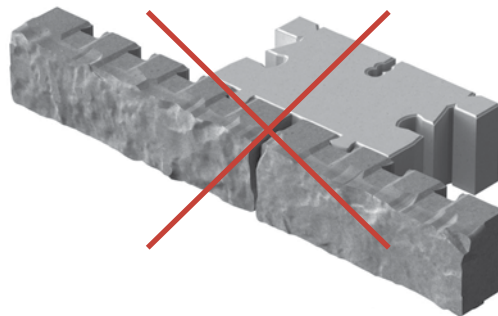
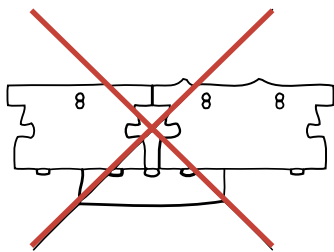
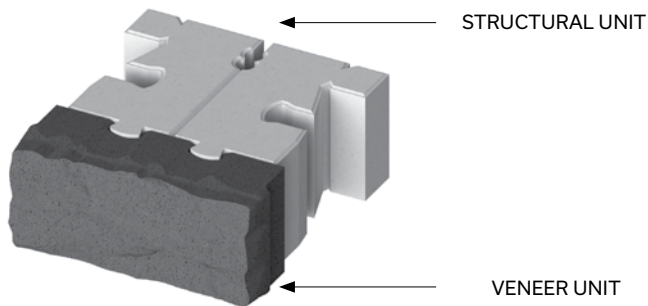

ATTENTION: In general, do not overlap two veneer units on a single structural unit of the same height, and do not overlap two structural units on a single veneer unit.

Building a Tandem Retaining Wall

STARTER UNIT

The first course of the Tandem wall is built using the Tandem wall starter unit. This is to be installed directly on the granular base foundation and levelled. The unit is bevelled to make it easy to install curved walls.

The use of starter units is strongly recommended given that the Tandem units (structural and veneer units) can then be placed on a uniform base ensuring overall wall stability.

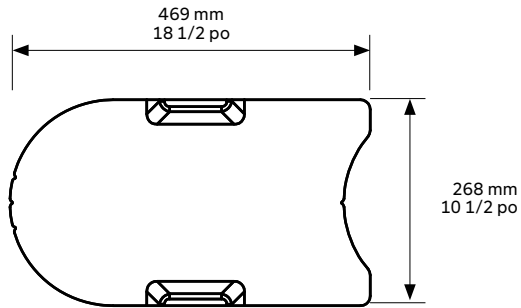

STARTER UNIT

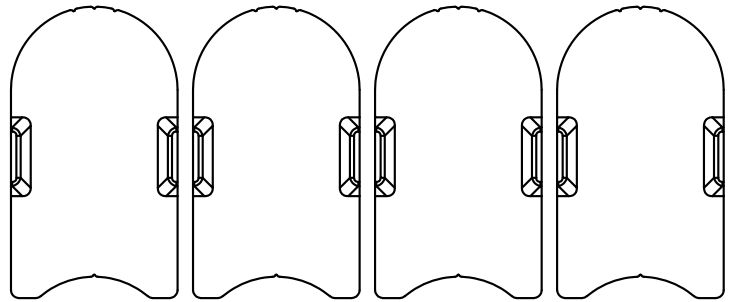

INSTALLATION OF STARTER UNITS
PLAN VIEW

PREASSEMBLY

90 unit: It is best to pre-assemble veneer and structural units before beginning to stack them in building the wall. Once pre-assembled, Tandem units are randomly installed on starter units, using the four different sizes.

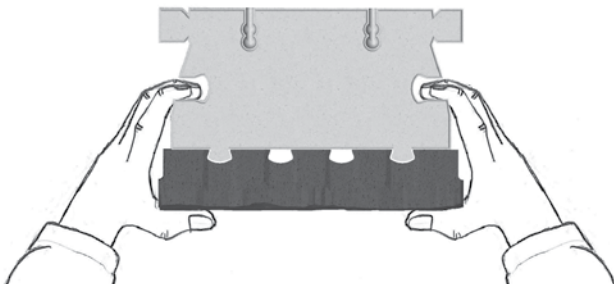

RECOMMENDED HANDLING FOR THE TANDEM 90 UNIT



STRUCTURAL UNIT



VENEER UNIT

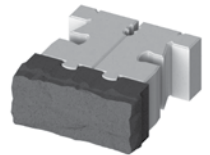

TANDEM UNIT

ANCHOR SYSTEM

The way in which the setback anchor is positioned in the Tandem wall system determines the slope of the wall. This positioning is what allows for either vertical or sloped walls.

Generally, at least one setback anchor must be installed per Tandem 90 unit, to make sure the wall is stable. Setback anchors come with or without blades. No-blade setback anchors are used in curved walls. Both types of anchor can be used in straight walls.

Allowable heights¹: 650 mm - 26 in. without a slope (0°, vertical);
1 050 mm - 42 in. with a slope of 9°

For a 9° of slope, the setback per row of 90 mm is 14 mm - 9/16 in.

¹ Maximum height of the wall including the buried portion of 150 mm - 6 in. without additional load or embankment above the wall

THERE ARE SEVERAL WAYS TO BUILD A TANDEM RETAINING WALL:

- > By using only Lafitt or Melville Tandem 90 units
- > By using only Lafitt or Melville Tandem 180 units

It is possible to use Lafitt and Melville Tandem Veneer units in the same wall.

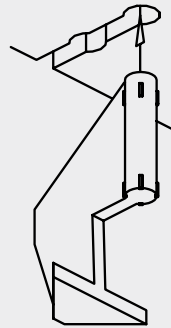

Position for building a wall on a 9° slope.
Maximum height of 1.05 m - 42 in.

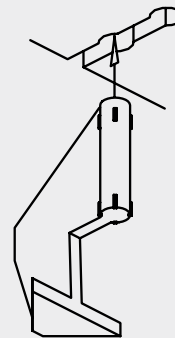

Position for building a vertical wall.
Maximum height of 0.65 m - 26 in.

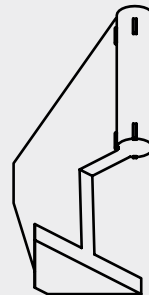

C1 - Base model

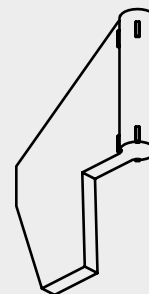

C2 - Model without blades

CROSS-SECTION - LAFITT AND MELVILLE TANDEM 90 WALL

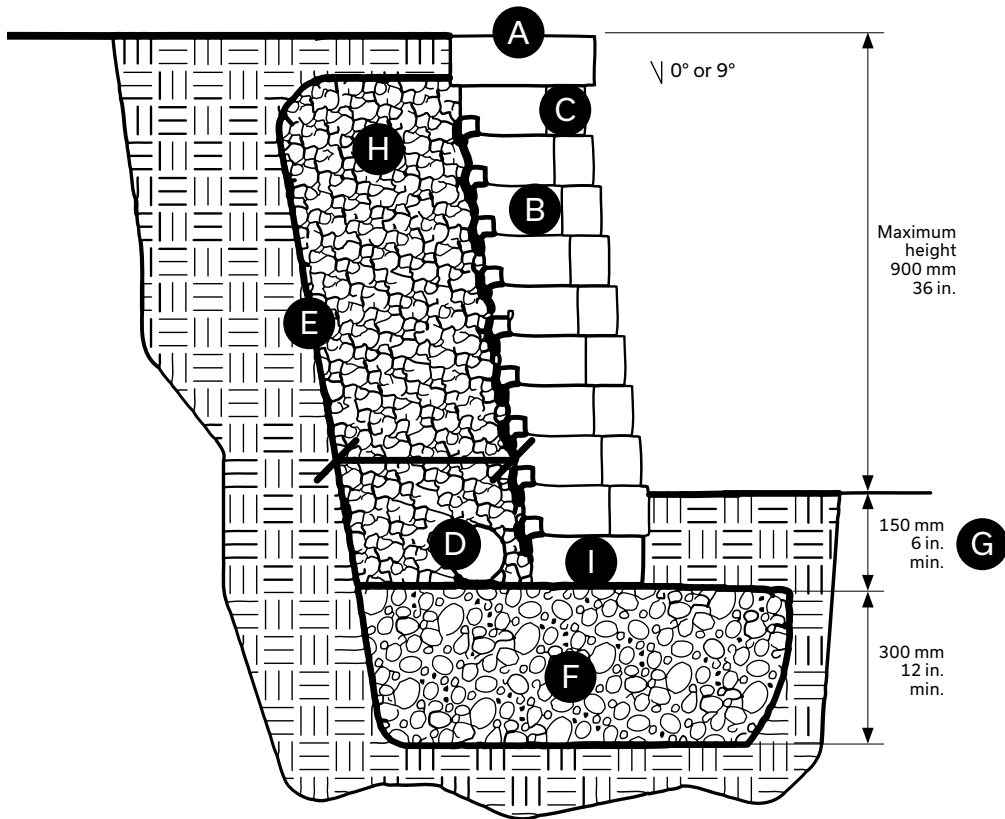

LAYING PATTERN

LINEAR PATTERN
100% Tandem 90

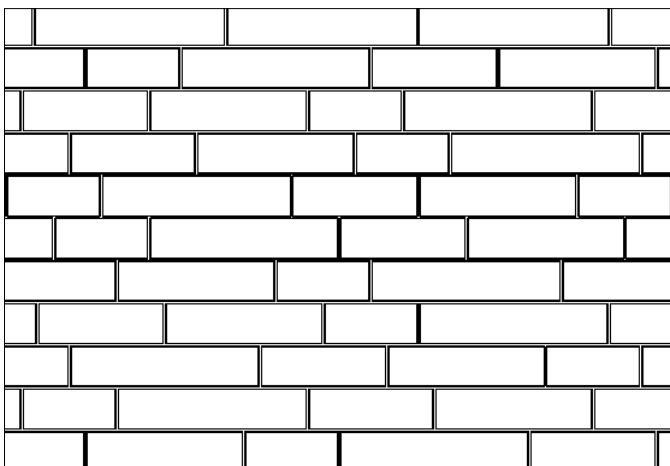

- A** Straight capping unit
90 x 305 x 400 mm - 3 9/16 x 12 x 15 3/4 in. OR
60 x 305 x 600 mm - 2 3/8 x 12 x 23 5/8 in.
- B** Structural unit 90 x 155 mm x variable
(201, 268, 335 ou 402 mm) - 3 9/16 x 6 1/8 in. x
variable (7 7/8, 10 1/2, 13 3/16, 15 13/16 in.)
- C** Veneer 90 mm unit (Tandem System)
- D** 100 mm Ø - 4 in. perforated drain pipe
connected to sewer services
- E** Geotextile membrane
- F** 0 to 20 mm - 0 to 3/4 in. compacted granular
foundation 300 mm - 12 in. minimum
- G** Minimum buried depth 150 mm - 6 in.
- H** Clean stone 20 mm - 3/4po, 300 mm minimum
- I** Starter unit 90 x 268 x 469 mm -
3 1/2 x 10 1/2 x 18 1/2 in.

BUILDING A RETAINING WALL

STRAIGHT WALL

To build straight Tandem walls, install the units randomly, using equal numbers of all unit sizes according to the typical cross-section and installation pattern associated with each type of walls.

When building a Tandem wall, avoid aligning vertical joints between rows as much as possible. Allow a minimum overlap of about 67 mm - 2 3/4 in. between units to make sure the vertical joints do not line up.

Lafitt Tandem wall (plan view)

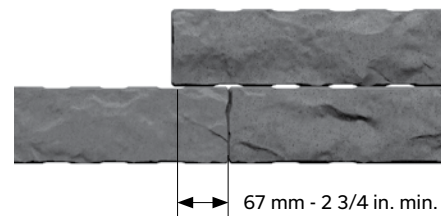
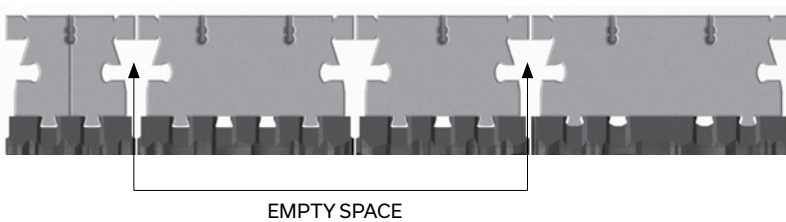

CURVED WALL

Using some Tandem units yields the minimum following curves:

	LAFITT TANDEM 90	MELVILLE TANDEM 90
Convex curves (outside)	1.5 m - 5 ft.	1.8 m - 6 ft.
Concave curves (inside)	1.2 m - 4 ft.	1.8 m - 6 ft.

Curved sections of walls must generally be built using the smallest units.

For a curved Tandem 90 wall, use units A, B and C. Their ends are bevelled to make it easier to install the curved wall.

Since Melville Tandem Veneers all have a textured side, the minimum bend radius is greater.

Remember that there will be a surplus of longer units for the remainder of the wall.

In building convex curves (outer curve), the wings of structural units may have to be cut off.

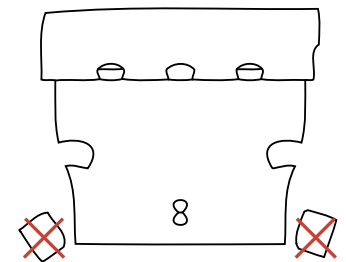

Cut off the extremities (wings) if necessary

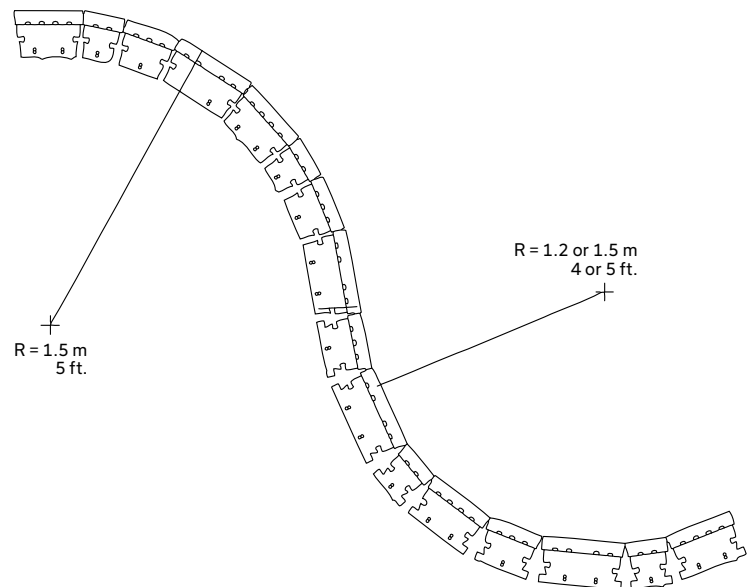

BUILDING A RETAINING WALL

90° CORNER WALL

When building a retaining wall, it is best to start with a corner to avoid breaks and alignment of vertical joints. Specially designed veneer units are needed to build a 90° corner. These units are called textured end units or corner veneer units.

LAFITT TANDEM

A Lafitt Tandem 90 cube contains 18 textured end veneer units per row. To form the corner, use B, C or D veneer units.

MELVILLE TANDEM

All of Melville Tandem Veneers have one textured side.

Stacking position on pallets (with a textured end)

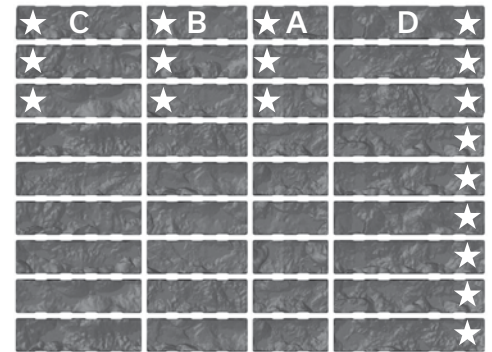

LAFITT TANDEM – 90 MM UNITS

LAFITT AND MELVILLE 90 MM 90° OUTER CORNER - BASIC PRINCIPLES

An outer corner is created using veneer units with the textured end out.

These units are reversible to form both left and right corners. For each course, the veneer that forms the corner is affixed to the structural unit using corner connectors designed specifically for this purpose. It is simply a question of alternating the placement of units from one course to the next. We recommend adhering the elements used to make the corner of each row using Techniseal concrete adhesive.

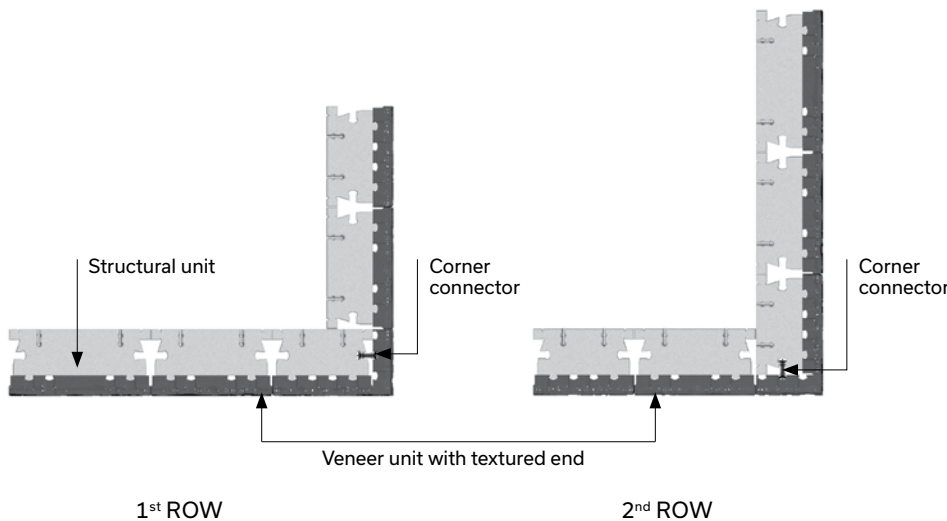

Spread the adhesive on the veneer units, or the structural units or on both

LAFITT AND MELVILLE 90 MM 90° OUTER CORNER - DETAILS

There are three ways of building a corner using Tandem 90 mm units:

OPTION 1

Use a corner veneer unit with a textured end B uncut and begin the wall perpendicularly, leaving an empty space that will be backfilled with clean stone.

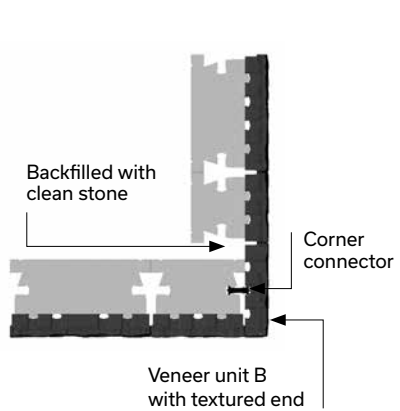

OPTION 2

Use a corner veneer unit with a textured end C or D, uncut, attached to a structural unit A cut in half.

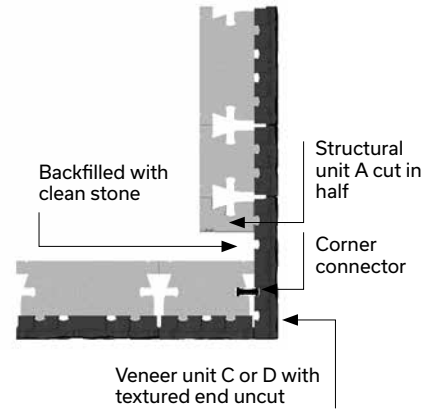

OPTION 3

Use a corner veneer unit with a textured end B, C or D, cut at 222 mm - 18 3/4 in. and begin the wall perpendicularly, pressing it up against the existing wall. Gently hammer the freshly cut side to obtain a similar finish as the other sides.

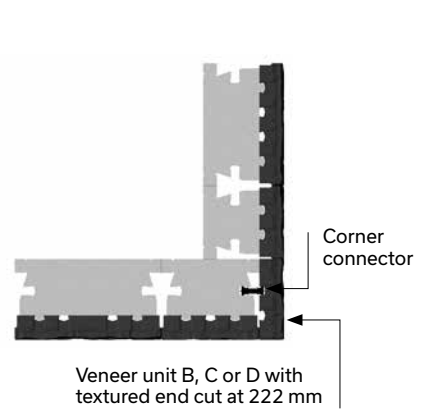

INTERIOR CORNER - BASIC PRINCIPLES

Build a Lafitt and Melville Tandem inner corner according to the principle shown here using Tandem 90 units C or D and 180 units E, F or G.

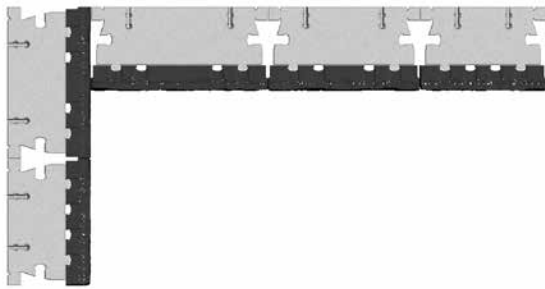

1st ROW

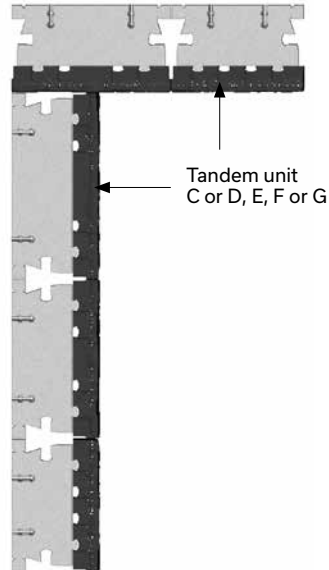

2nd ROW

45° CORNER

It is also possible to build corners on a 45° angle. Simply cut each Tandem unit used to make the corner on a 22.5° angle. These Tandem units must be adhered together using Techniseal concrete adhesive on the horizontal and vertical sides.

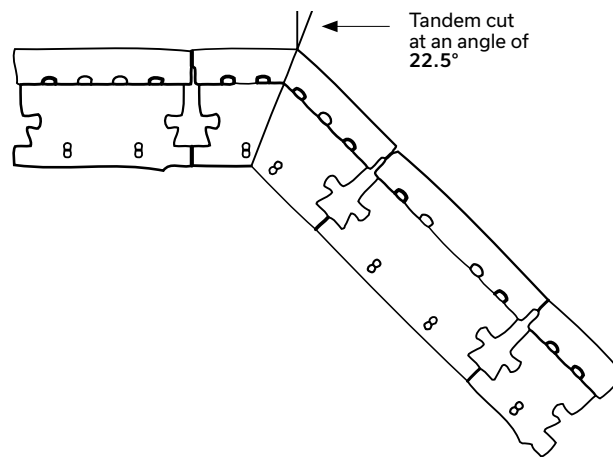

RETAINING WALL CAPPING

LAFITT AND MELVILLE TANDEM WALLS

The Lafitt Tandem retaining wall is completed using **Lafitt capping units** (90 x 305 x 400 mm).

The Melville Tandem wall is finished with the use of **Melville capping units** (60 mm x 305 mm x 600 mm).

To cap a wall with a 90° corner, capping units must be cut at a 45° angle (see illustration).

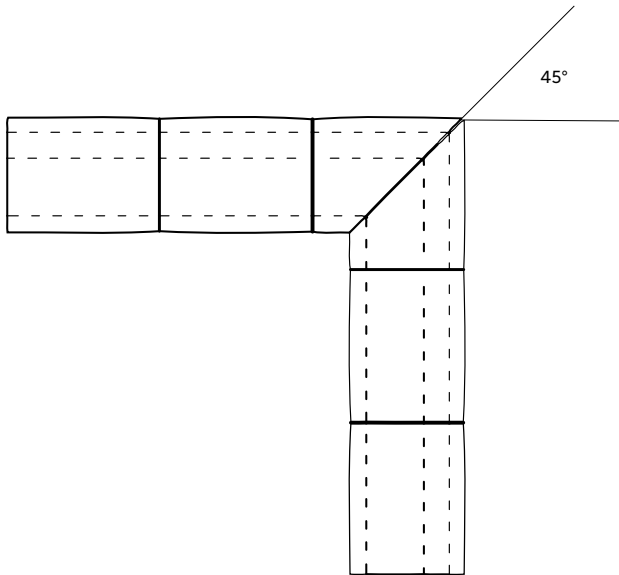

Lafitt or Melville capping units are also used to cap curved walls. The units must be bevelled on site to match the final shape of the wall.

OPTIONS: Straight capping units from the Celtik wall system unit can also be used to highlight the wall's finish (different colours and textures).

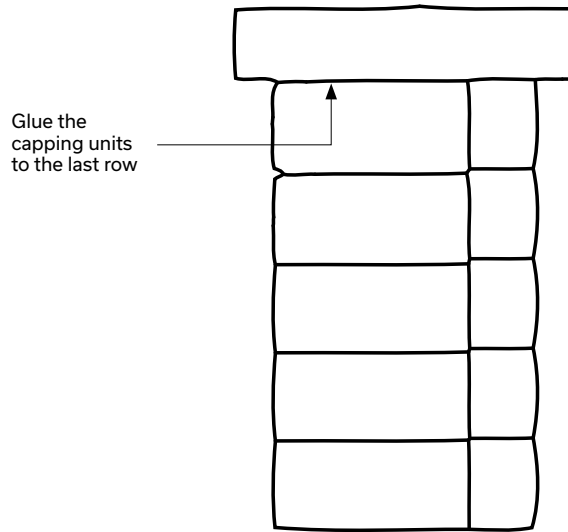

NOTE: All capping units must be glued to the last row of Tandem units using Techniseal concrete adhesive. Make sure the surface is clean, so that the capping can be glued to the top course with Techniseal concrete adhesive.

Building a Double-Sided Wall

DOUBLE-SIDED TANDEM UNIT ASSEMBLY



Installing a double-sided wall requires the use of two veneer units held together using connectors. Connectors are inserted into the mortises on the veneer units thus connecting them two by two in order to create the double-sided Tandem unit. The work is complete once 20 mm - 3/4 in. clean stone is placed between the veneers of every other course, and the capping unit is installed. Lafitt and Melville Tandem 90 and 180 veneer units can be used to build straight or curved double-sided walls, as well as 90° corners.

ALLOWABLE HEIGHTS

The Tandem wall system can be used to build a double-sided wall with a maximum above-ground height of 711 mm - 28 in. The wall is built completely vertical without a slope.

STARTER UNITS

To build the double-sided Tandem wall, begin by placing the starter unit directly on the granular base perpendicular to the wall and leveling it.

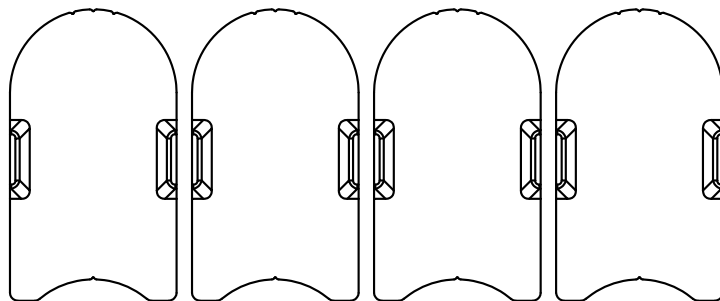
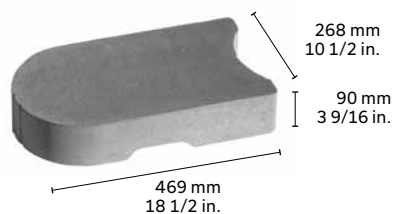

INSTALLATION OF STARTER UNITS
PLAN VIEW

PLASTIC CONNECTORS

TANDEM DOUBLE-SIDED UNITS 90 AND 180 mm

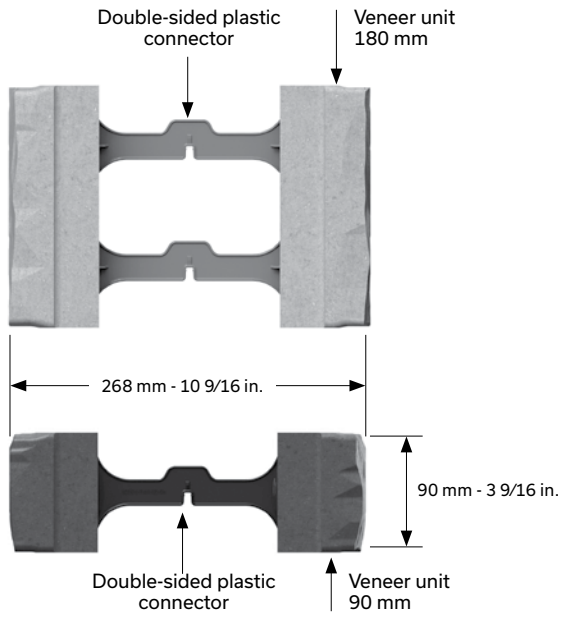

3-D VIEW

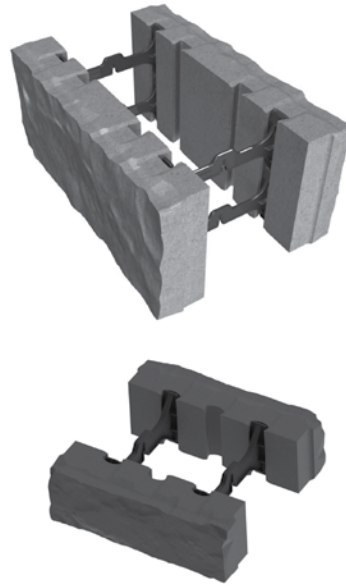

BUILDING A DOUBLE-SIDED WALL

DETAILS

THERE ARE SEVERAL WAYS TO BUILD A DOUBLE-SIDED WALL:

- > Using only Lafitt or Melville Tandem 90 units
- > Using only Lafitt or Melville Tandem 180 units
- > Using a combination of Lafitt or Melville Tandem 90 and 180 units together

To build a solid structure, the empty space inside the double-sided Tandem unit with plastic connectors must be filled with 20 mm - 3/4 in. clean stone on every second row. Before installing the capping, tap lightly on each side of the wall with a rubber hammer to help compact the aggregate between the veneer units.

Double-sided Tandem units are randomly installed on starter units, using an equal number of all units. The same installation

patterns as for retaining walls are used here (see the installation patterns in the RETAINING WALL section). Each veneer unit of the first row must be glued to the starter units with Techniseal concrete adhesive.

QUANTITY OF CONNECTORS REQUIRED:

Lafitt and Melville Tandem 90 wall

7 connectors per sq. ft of double-sided wall (74 connectors per m²) based on one of the sides of the wall.

Lafitt and Melville Tandem 180 wall

5.5 connectors per sq. ft of double-sided wall (57 connectors per m²) based on one of the sides of the wall.

WE RECOMMEND GLUING ALL OF THE ROWS TOGETHER FOR A DOUBLE-SIDED WALL USING LAFITT AND MELVILLE TANDEM.

90 mm STRAIGHT DOUBLE-SIDED WALL

DOUBLE-SIDED LAFITT AND MELVILLE TANDEM WALL WITH 90 mm VENEER UNITS AND PLASTIC CONNECTORS

When building a straight wall, assemble veneer units of the same size using the double-sided connector. Because the veneer units come in different lengths, several layouts are possible.

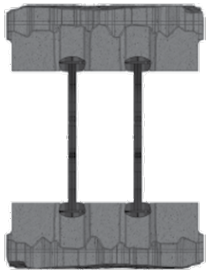

UNITS A-A
90 x 67 x 201 mm
3 9/16 x 2 5/8 x 7 7/8 in.



UNITS B-B
90 x 67 x 268 mm
3 9/16 x 2 5/8 x 10 1/2 in.

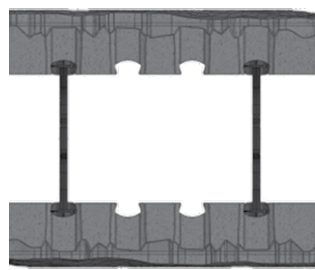

UNITS C-C
90 x 67 x 335 mm
3 9/16 x 2 5/8 x 13 3/16 in.

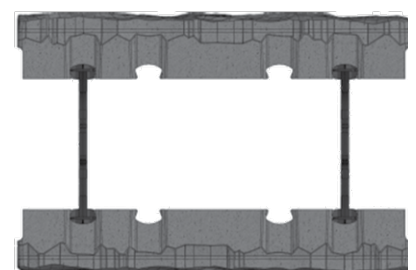

UNITS D-D
90 x 67 x 402 mm
3 9/16 x 2 5/8 x 15 13/16 in.

TYPICAL CROSS-SECTION - DOUBLE-SIDED 90 mm VENEER UNITS

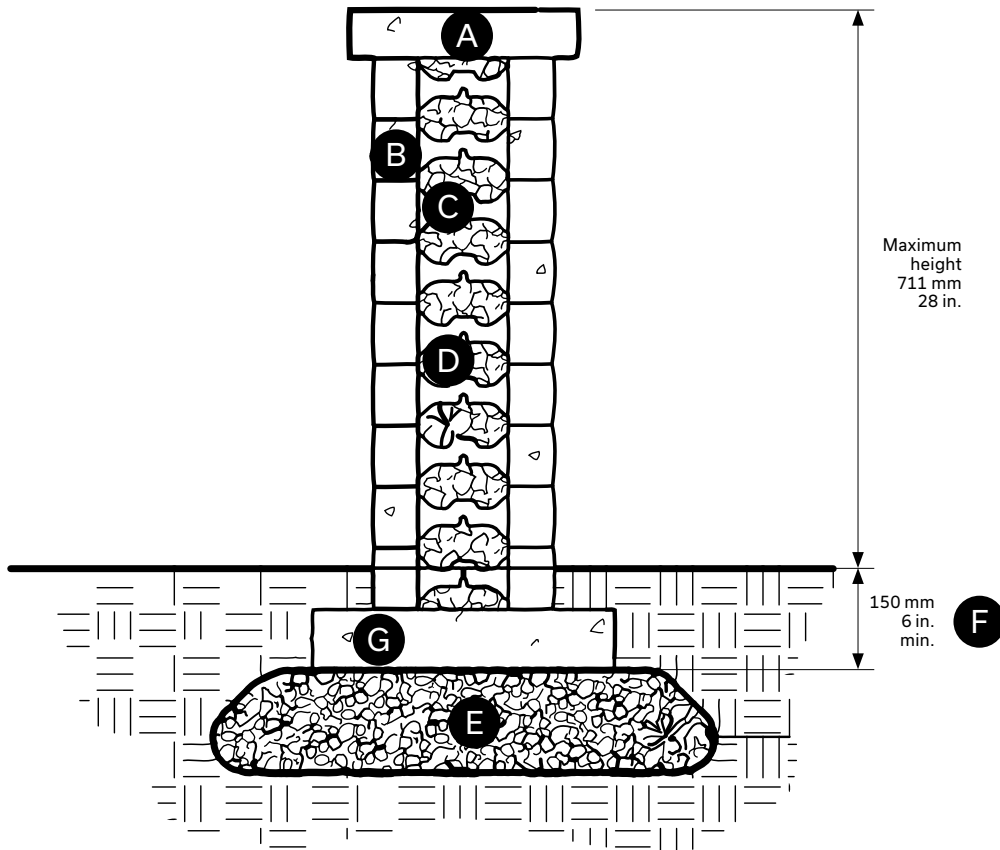

- A** Melville Plus capping unit
60 x 305 x 600 mm - 2 3/8 x 12 x 23 5/8 in.
- B** 90 mm veneer unit (Tandem System)
- C** Double-sided connector
- D** Clean stone 20 mm - 3/4 in., 300 mm minimum
- E** 0 to 20 mm - 0 to 3/4 in. compacted granular foundation 300 mm - 12 in. minimum
- F** Minimum buried depth 150 mm - 6 in.
- G** Tandem Next starter unit 90 x 268 x 469 mm - 3 9/16 x 10 1/2 x 18 1/2 in.

BUILDING A DOUBLE-SIDED WALL

180 mm STRAIGHT DOUBLE-SIDED WALL

DOUBLE-SIDED LAFITT AND MELVILLE TANDEM WALL WITH 180 mm VENEER UNITS AND PLASTIC CONNECTORS

When building a straight wall, assemble veneer units of the same size using the double-sided connector. Because the veneer units come in different lengths, several layouts are possible.

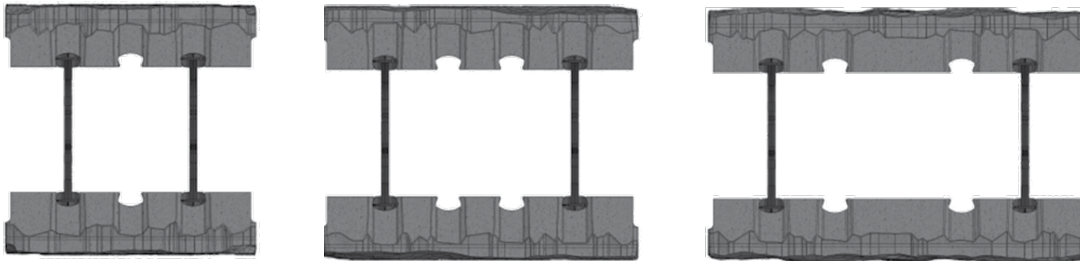

NOTE: Tandem 180 wall units must be assembled using pairs of double-sided connectors installed one on top of the other for greater stability.

UNITS E-E
180 x 67 x 335 mm
7 1/16 x 2 5/8 x 13 3/16 in.

UNITS F-F
180 x 67 x 402 mm
7 1/16 x 2 5/8 x 15 3/16 in.

UNITS G-G
180 x 67 x 469 mm
7 1/16 x 2 5/8 x 18 1/2 in.

TYPICAL CROSS-SECTION - DOUBLE-SIDED 180 mm VENEER UNITS

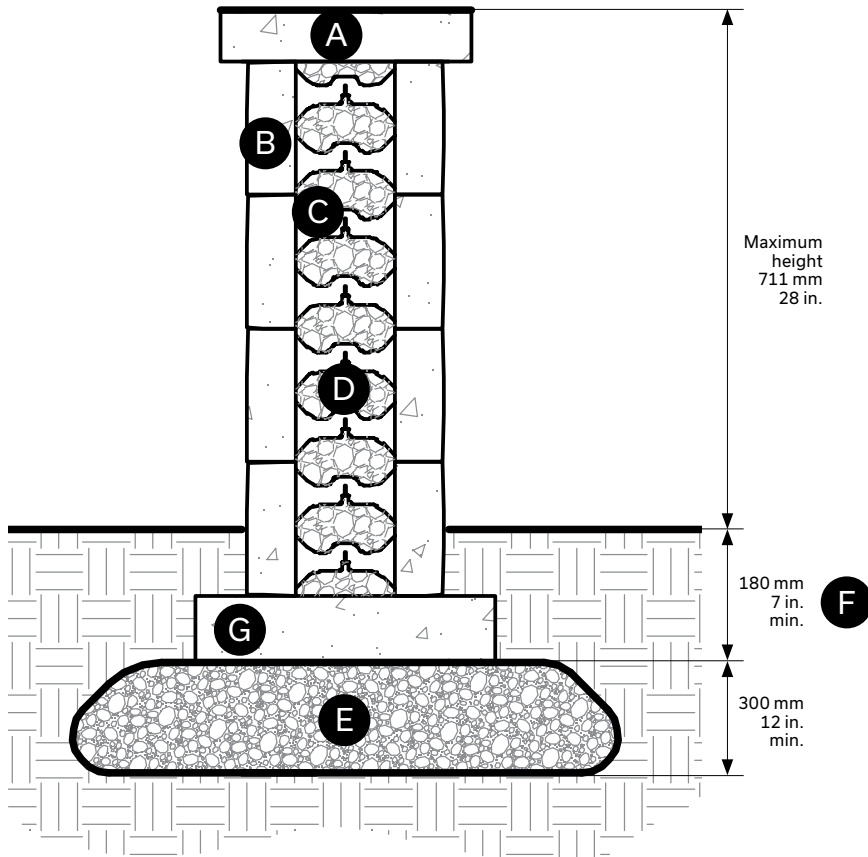

- A** Melville Plus capping unit
60 x 305 x 600 mm - 2 3/8 x 12 x 23 5/8 in.
- B** 180 mm veneer unit (Tandem System)
- C** Double-sided plastic connector
- D** Clean stone 20 mm - 3/4 in., 300 mm minimum
- E** 0 to 20 mm - 0 to 3/4 in. compacted granular foundation 300 mm - 12 in. minimum
- F** Minimum buried depth 150 mm - 6 in.
- G** Tandem Next starter unit 90 x 268 x 469 mm - 3 9/16 x 10 1/2 x 18 1/2 in.

TYPICAL CROSS-SECTION - DOUBLE-SIDED 90 mm and 180 mm VENEER UNITS

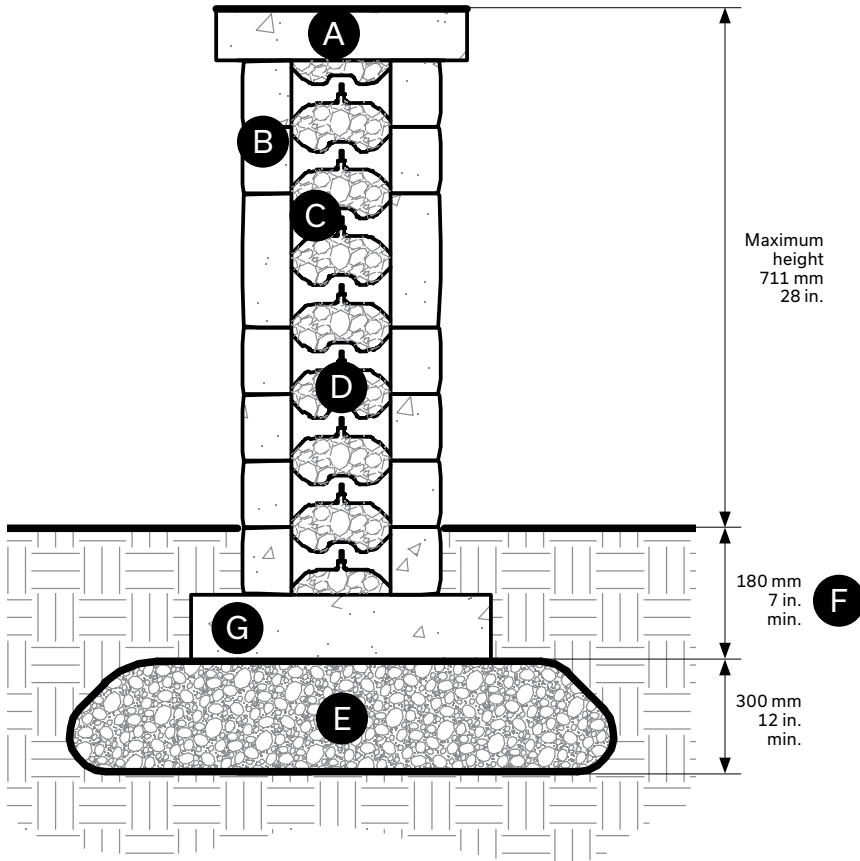

- Ⓐ Melville Plus capping unit
60 x 305 x 600 mm - 2 3/8 x 12 x 23 5/8 in.
- Ⓑ 90 mm or 180 mm veneer unit (Tandem System)
- Ⓒ Double-sided plastic connector
- Ⓓ Clean stone 20 mm - 3/4 in., 300 mm minimum
- Ⓔ 0 to 20 mm - 0 to 3/4 in. compacted granular foundation 300 mm - 12 in. minimum
- Ⓕ Minimum buried depth 150 mm - 6 in.
- Ⓖ Tandem Next starter unit 90 x 268 x 469 mm - 3 9/16 x 10 1/2 x 18 1/2 in.

BUILDING A DOUBLE-SIDED WALL

90 mm CURVED DOUBLE-SIDED WALL

CURVED DOUBLE-SIDED LAFITT AND MELVILLE TANDEM WALL WITH 90 mm VENEER UNITS AND PLASTIC CONNECTORS

To build a curved double-sided wall, while maximizing results and minimizing sizes, only the following pairs of veneer units are recommended for use:

A-A, A-B, B-B and B-C for 90 mm units and E-E, E-F, F-F and F-G for 180 mm units. Consequently, there will be more D veneer units for the remainder of the wall. Some units may have to be cut to fit perfectly into the selected curve. The design flexibility of double-sided units means that connectors can be inserted in all unit mortises, providing for better adjustment in creating curves with different radii.



UNITS A-B

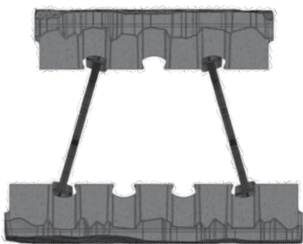

UNITS B-C

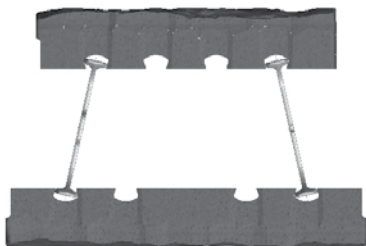

UNITS E-F

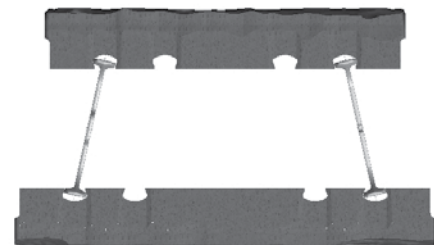

UNITS F-G

The minimum curves possible for the Lafitt Tandem wall:
90 mm = 1.5 m - 5 ft
180 mm = 1.8 m - 6 ft

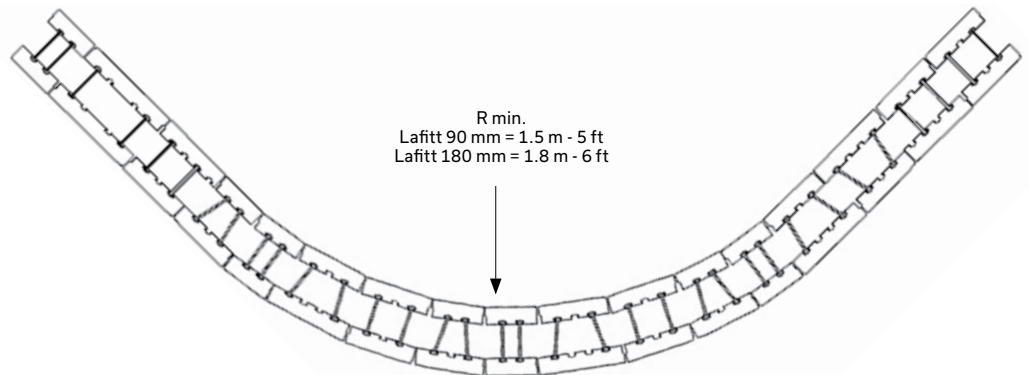

CURVED TANDEM WALL WITH PLASTIC CONNECTORS

90 mm DOUBLE-SIDED WALL END

END OF DOUBLE-SIDED LAFITT AND MELVILLE TANDEM WALL WITH PLASTIC CONNECTORS

The end of a double-sided Tandem 90 wall is built using a textured end veneer unit A installed on the end of the wall.

To ensure solid corner assembly, two double-sided connectors are overlapped in a cross shape and inserted into the mortises on the veneer units. The first connector connects the two double-sided wall veneer units, while the perpendicular connector connects the textured end veneer unit that forms the end of the wall. Glue every course forming the end of the wall using Techniseal concrete adhesive.

The end of a double-sided Tandem 180 wall is built using a textured end veneer unit E cut at 201 mm and installed on the end of the wall.

Connectors installed in a cross shape



ISOMETRIC VIEW

ASSEMBLY FOR DOUBLE-SIDED 90 mm WALL: END OF WALL

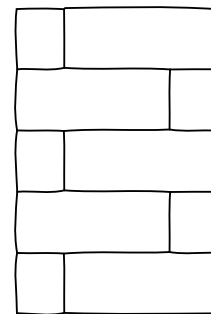
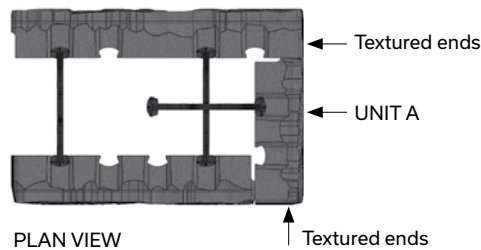

END OF WALL - SIDE VIEW

ASSEMBLY FOR DOUBLE-SIDED 180 mm WALL: END OF WALL

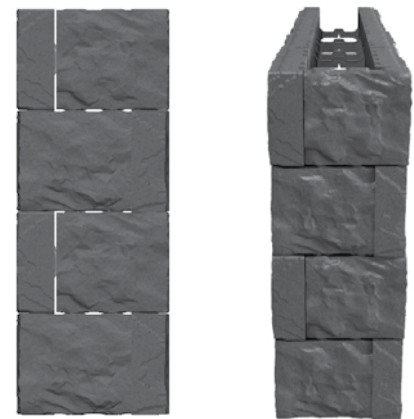
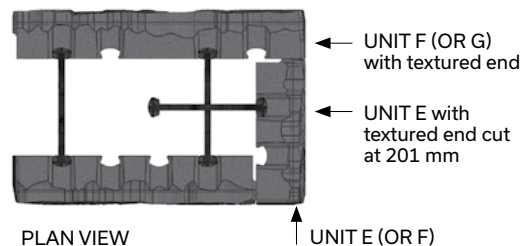

ELEVATION VIEW

END OF A DOUBLE-SIDED LAFITT AND MELVILLE TANDEM DOUBLE 90 AND 180 WALL

The end of a double-sided 90 and 180 wall is built by smoothly combining the two kinds of construction (90 and 180) for a wall end, described previously in this document. To build an end for a wall that mixes Tandem 90 and 180 units in the same wall, for each given row height, use units of the same height.

BUILDING A DOUBLE-SIDED WALL

DOUBLE-SIDED WALL WITH 90° CORNERS

DOUBLE-SIDED WALL WITH 90° CORNERS AND PLASTIC CONNECTORS

Building a 90° corner on a Lafitt and Melville Tandem wall requires installing a wall end (described earlier), then juxtaposing a second wall perpendicular to it. Glue every course in the wall corner using Techniseal concrete adhesive.

Once again, for a natural look, avoid aligning vertical joints from one row to the next on all visible surfaces.

PLAN VIEW

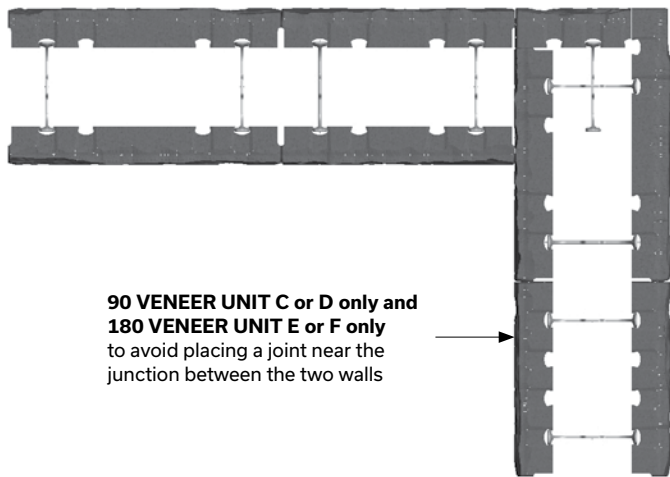

1st COURSE and all odd courses

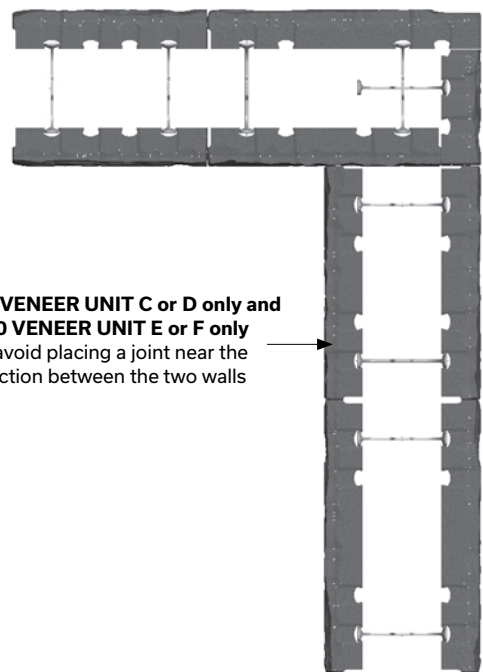

2nd COURSE and all even courses

BUILDING A DOUBLE-SIDED WALL

DOUBLE-SIDED WALL WITH 90° CORNERS (CONT'D)

90° CORNER IN A DOUBLE-SIDED 90 mm AND 180 mm WALL

Building a 90° corner on a wall requires installing a wall end (described earlier), then juxtaposing a second wall perpendicular to it. The second wall can be built starting with double-sided Tandem 90 or 180 units. Adhere every course in the wall corner using Techniseal concrete adhesive.

Corners are built using the options available for that height (90 or 180). These options were illustrated and explained earlier in this document. The selection of corner unit heights and their positioning in the wall is a matter of aesthetics. The 90 and 180 units must be inserted in a similar proportion to the remainder of the wall so that they harmonize.

CAPPING A DOUBLE-SIDED WALL

Double-sided Tandem walls are completed using Melville Plus capping (60 mm x 305 mm x 600 mm) laid side by side. To cap a 90° corner, simply install two capping units at a 90° angle. For curved walls, capping units must be bevelled on site to match the final shape of the wall.

Options: Celtik wall system capping units and Melville capping units can also be used.

PLAN VIEW

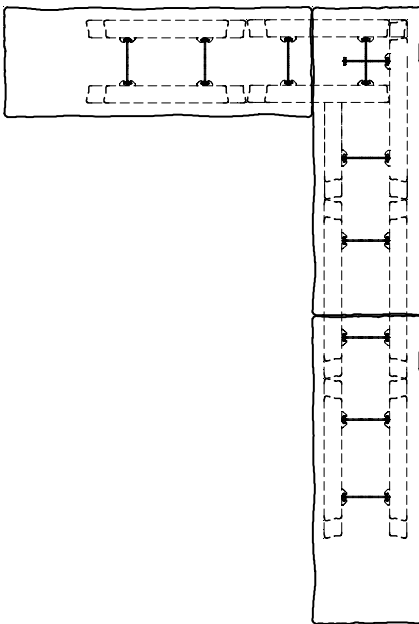

Note that all capping units must be attached to the last row of Tandem units using Techniseal concrete adhesive.

Building Stairs



MELVILLE 60 STEPS

To build Melville Plus 60 stairs, we suggest using Melville Plus 60 units combined with Melville Tandem Plus 180 units used as risers, as shown here:

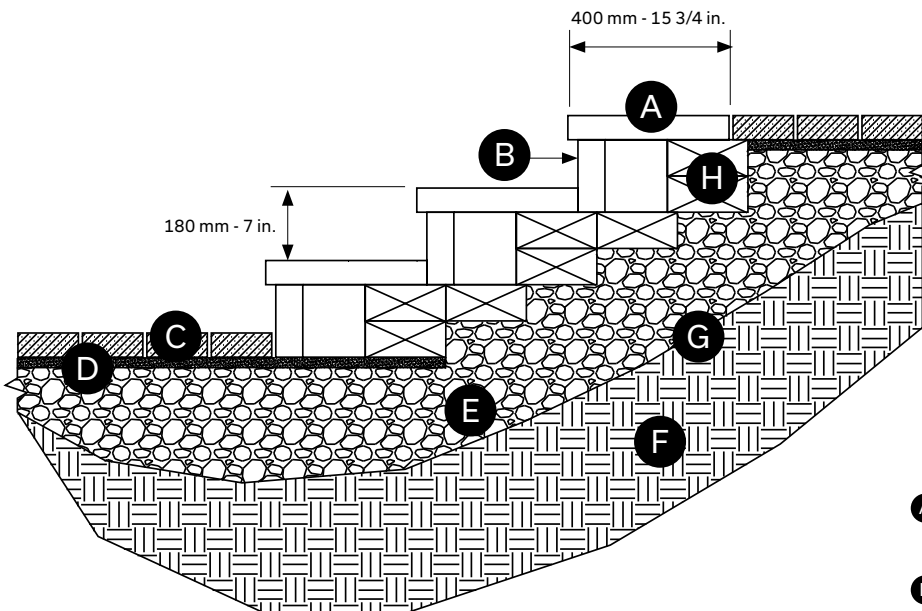

- A** Melville Plus 60 step
60 x 400 x 600 mm - 2 3/8 x 15 3/4 x 23 5/8 in.
- B** Structural and veneer Melville Tandem 180 unit
- C** Concrete paver 60 mm - 2 3/8 in.
- D** Installation bed 25 mm - 1 in.
- E** 0 to 20 mm - 0 to 3/4 in. compacted granular foundation
- F** Existing soil
- G** Geotextile membrane
- H** Starter unit 90 x 268 x 469 mm - 3 1/2 x 10 1/2 x 18 1/2 in.

MELVILLE TANDEM 60 STEP UNITS STAIR INTEGRATION / TANDEM WALL

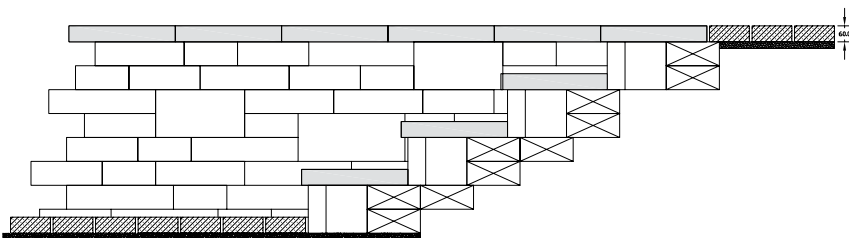

All step and riser units must be glued together using Techniseal concrete adhesive.



MELVILLE 90 STEPS

To build Melville Plus 90 stairs, we suggest using Melville Plus 90 units combined with Melville 90 units used as risers, as shown here:

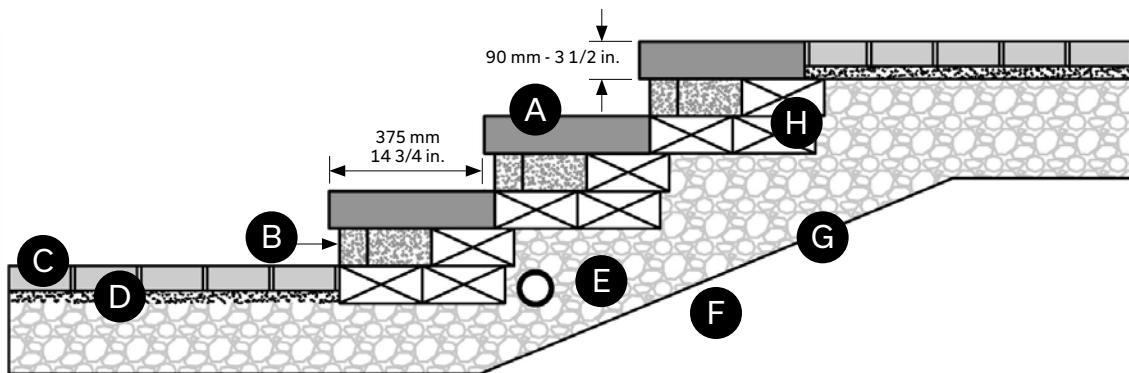

- A** Melville Plus 90 step
60 x 400 x 600 mm - 2 3/8 x 15 3/4 x 23 5/8 in.
- B** Structural and veneer Melville Tandem
90 unit
- C** Concrete paver 60 mm - 2 3/8 in.
- D** Installation bed 25 mm - 1 in.
- E** 0 to 20 mm - 0 to 3/4 in. compacted
granular foundation
- F** Existing soil
- G** Geotextile membrane
- H** Starter unit 90 x 268 x 469 mm -
3 1/2 x 10 1/2 x 18 1/2 in.

All step and riser units must be glued together using Techniseal concrete adhesive.

LAFITT 90 STEPS

To build Lafitt Tandem stairs, it is recommended that the step unit be used in combination with one of the following options for the riser:

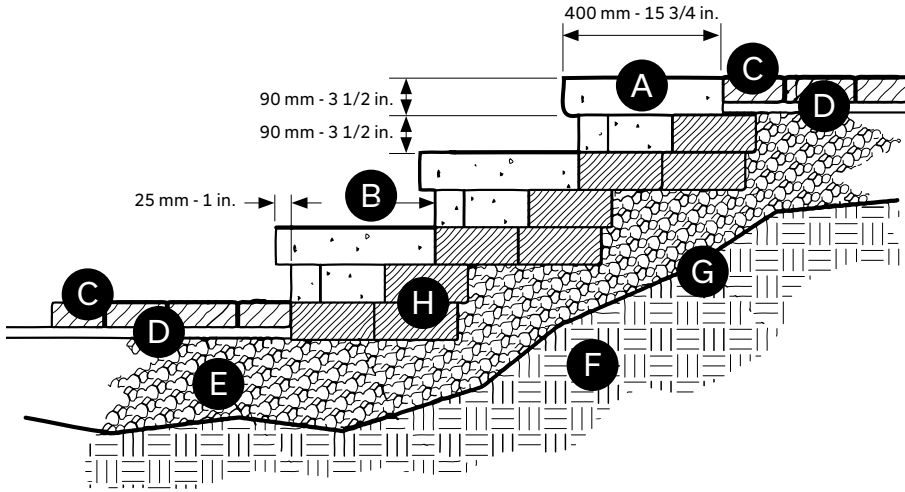

OPTION 1

Structural unit and Lafitt Tandem veneer
 90 x 222 mm x variable - 3 9/16 x 8 3/4 x variable

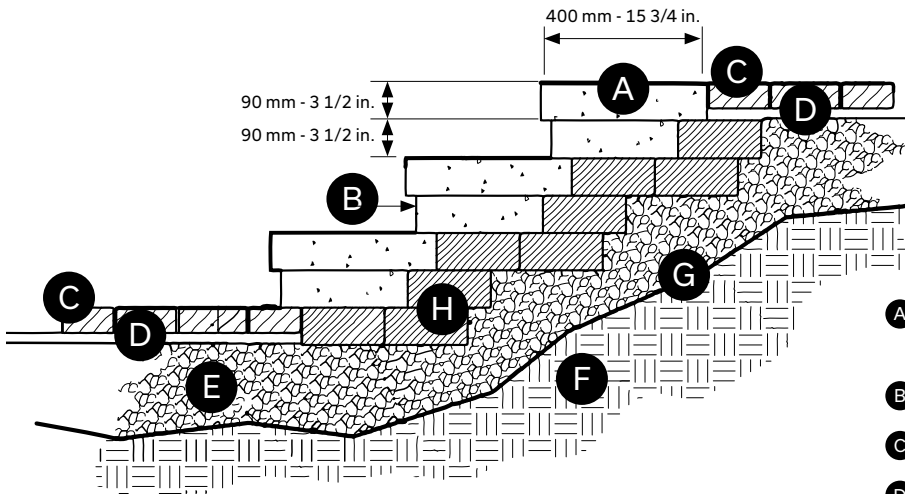

OPTION 2

Lafitt straight capping unit
 90 x 305 x 400 mm - 3 1/2 x 12 x 15 3/4 in.

- A** Lafitt Plus 90 step unit
90 x 400 x 400 mm - 3 1/2 x 15 3/4 x 15 3/4 in.
- B** **OPTION 1** or **OPTION 2**
- C** Concrete paver 60 mm - 2 3/8 in.
- D** Installation bed 25 mm - 1 in.
- E** 0 to 20 mm - 0 to 3/4 in. compacted granular foundation
- F** Existing soil
- G** Geotextile membrane
- H** Starter unit 90 x 268 x 469 mm - 3 1/2 x 10 1/2 x 18 1/2 in.

All step and riser units must be glued together using Techniseal concrete adhesive.

Building Pillars

DIFFERENT TYPES OF TANDEM PILLARS



This section discusses the different types of pillars which can be built using the Tandem system, namely:

- > Tandem pillars with steel pillar grids
- > Tandem pillars with structural units

Tandem Veneer units are used for the exterior facing of the pillar. The interior core of the column serves a structural function and can be built in accordance with one of the following two methods: using structural units (regular Tandem system) or using a steel pillar grid instead of structural units (Tandem pillar grid).

TANDEM PILLARS WITH PILLAR GRIDS

This type of pillar is built with Lafitt and Melville Tandem Veneer units only. The building of this type of column begins with the use of a steel pillar grid which provides structural support for the veneer units. The units are fastened to the pillar grid using specially-designed connectors.

The essential details for building this type of pillar are described below.

90 mm LAFITT AND MELVILLE TANDEM COLUMN WITH PILLAR GRID ASSEMBLY

With this material you can construct one pillar of 670 x 670 mm - 26 3/8 x 26 3/8 in. to a maximum height of 1080 mm - 42 1/2 in.

One pillar requires the use of 2.6 m² - 28 ft² of veneer units.

One cube contains 10 pillar grids and 10 bags of 200 grid connectors.

MATERIAL NEEDED:



GRID CONNECTORS
Bag of 200 units

LAFITT or MELVILLE TANDEM veneer units:

- > 48 regular units (12a, 12b, 12c, 12d)
- > 48 textured end corner units (12a, 12b, 12c, 12d)

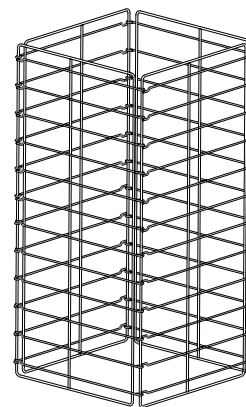

TANDEM PILLAR GRID

NOTE: All Melville veneer units come with one textured end (corner units)

CROSS-SECTION - LAFITT OR MELVILLE TANDEM PILLAR GRID

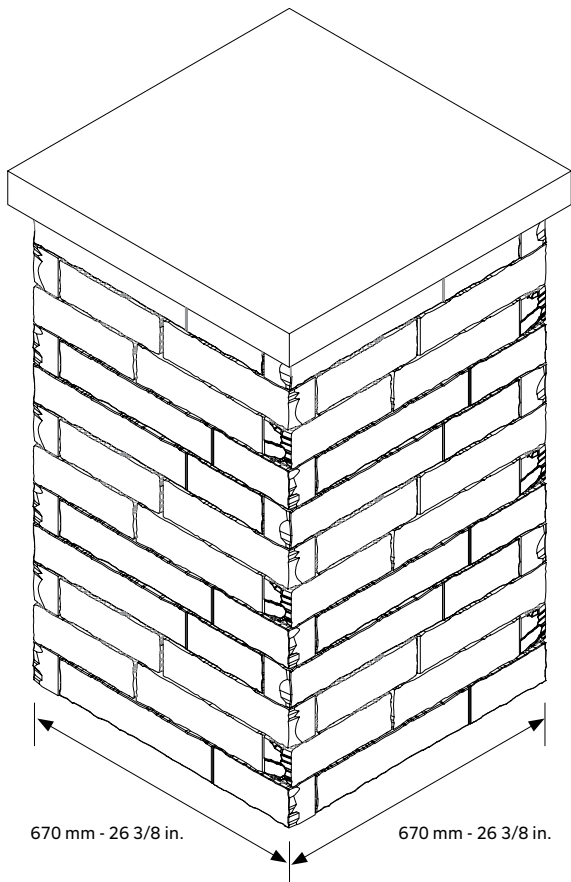
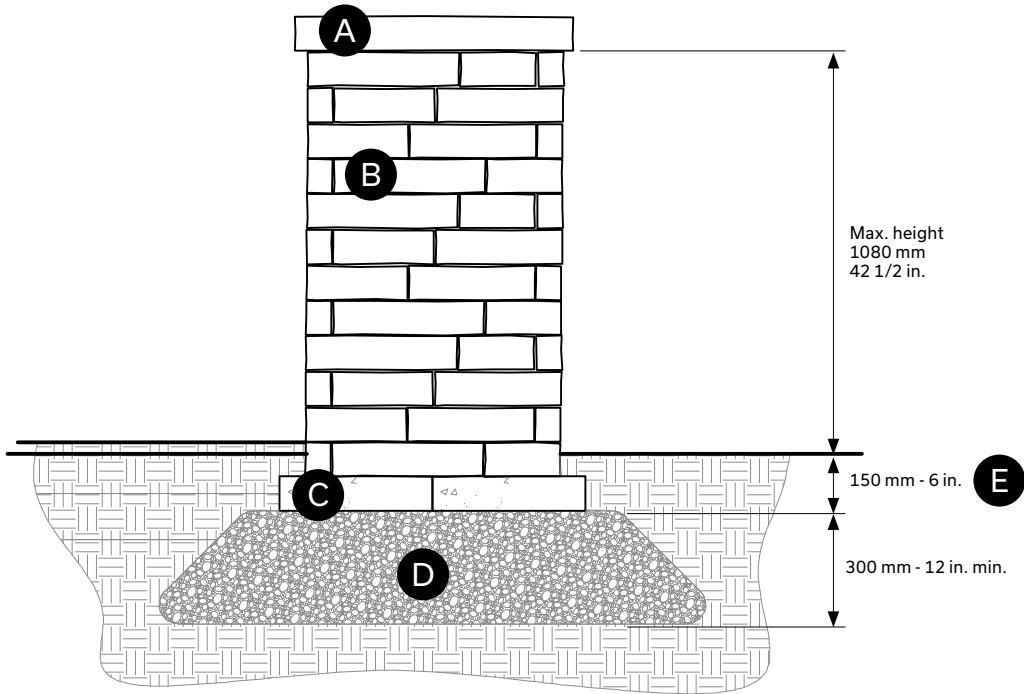

- A** Natural stone pillar capping unit 29 x 29 in.
- B** 90 mm Lafitt or Melville Tandem veneer unit
- C** Starter unit 90 x 268 x 469 mm - 3 1/2 x 10 1/2 x 18 1/2 in.
- D** 0 to 20 mm - 0 to 3/4 in. compacted granular foundation, 300 mm - 12 in. minimum
- E** Minimum buried depth 150 mm - 6 in.

LAFITT OR MELVILLE TANDEM PILLAR ASSEMBLY

Begin by placing a row (8 units) of starter units on a base of compacted crushed stone. Unfold the steel pillar grid and place it on the prepared surface.

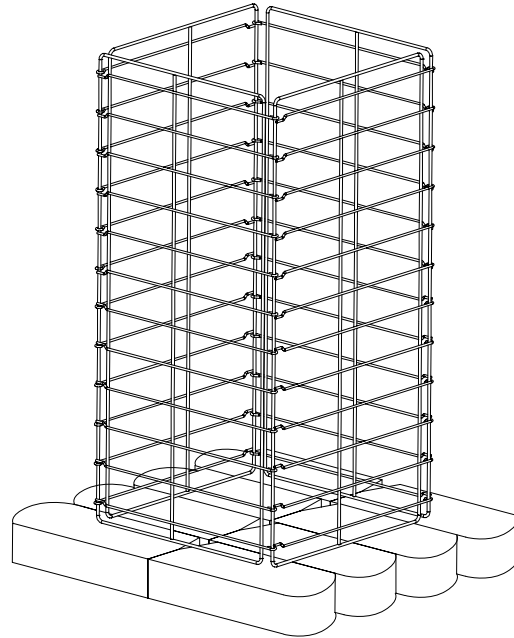
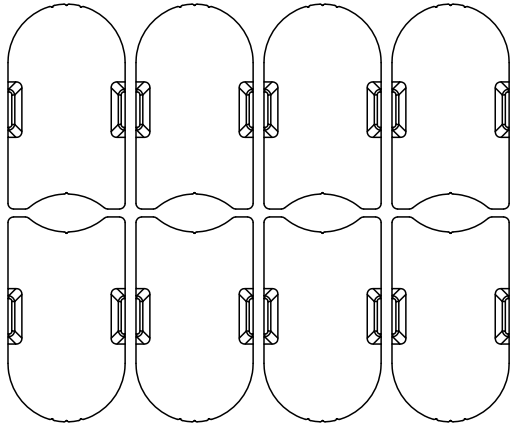

1st ROW OF STARTER UNITS

Insert the pillar connectors (using 2 connectors for each unit) into the veneer units which form the first row of the pillar. Place the veneer units for the first row around the steel pillar grid, making sure to "click" the connectors onto the horizontal wires (refer to the recommended installation pattern for the veneer units which have been selected).

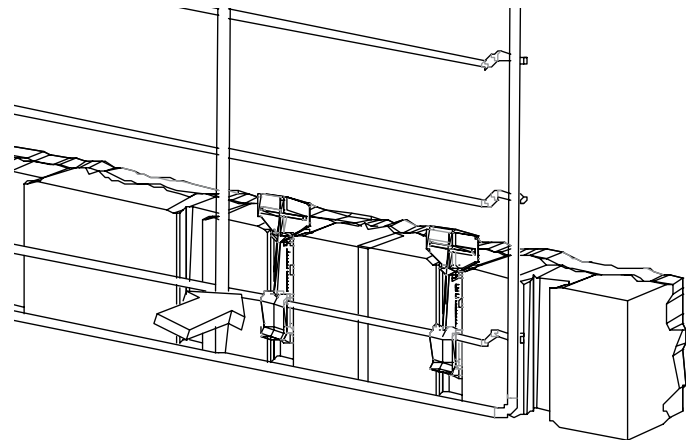
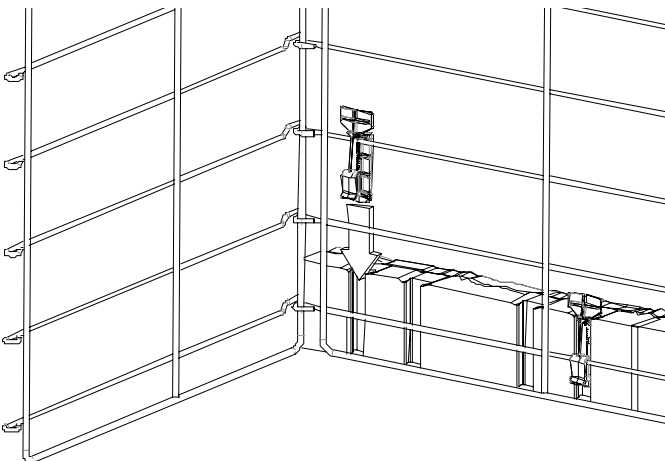

BUILDING PILLARS

LAFITT OR MELVILLE TANDEM PILLAR ASSEMBLY (CONT'D)

The corners of the pillar can be built easily by sliding the units along the wire until they line up with the corner unit which was installed previously.

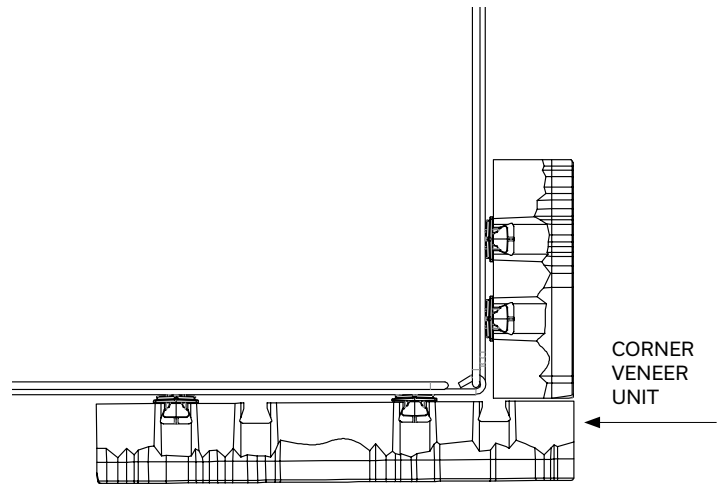
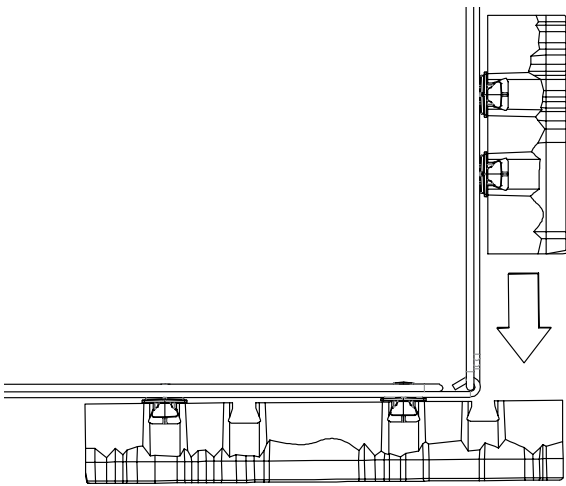
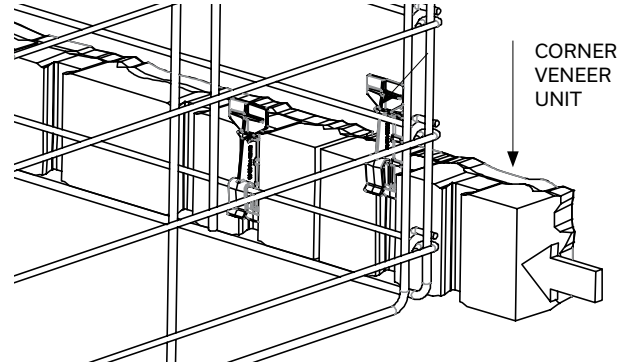
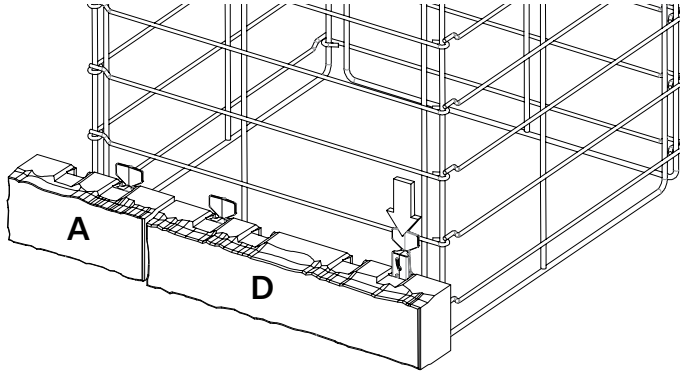

LAYING PATTERNS

TANDEM PILLAR WITH 90 mm UNITS
First 4 rows (over the starter units) 360 mm - 14 in.

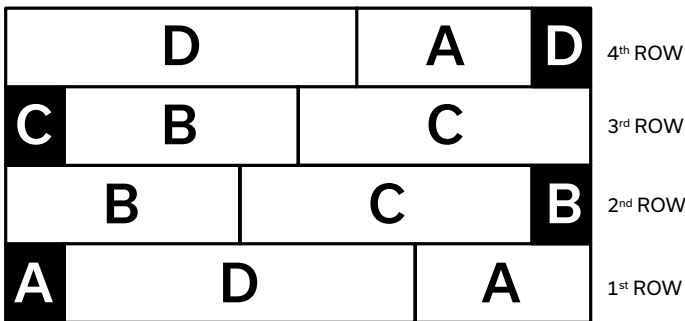

Installation pattern to repeat up to DESIRED HEIGHT

90 mm TANDEM PILLAR WITH 180 mm UNITS
First 5 rows (over the starter units) - for reference only

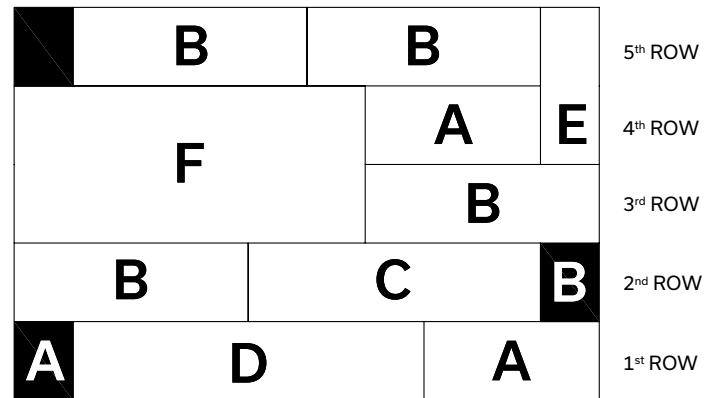

Installation pattern to repeat up to DESIRED HEIGHT

LAFITT OR MELVILLE TANDEM 90 mm PILLAR ASSEMBLY

Once the first row has been completed, fill the interior space with clean 20 mm aggregate, and then use a square to ensure that the corner units are perpendicular to each other. Repeat this step after every second row has been completed. Install subsequent rows in the same manner, up to the desired height.

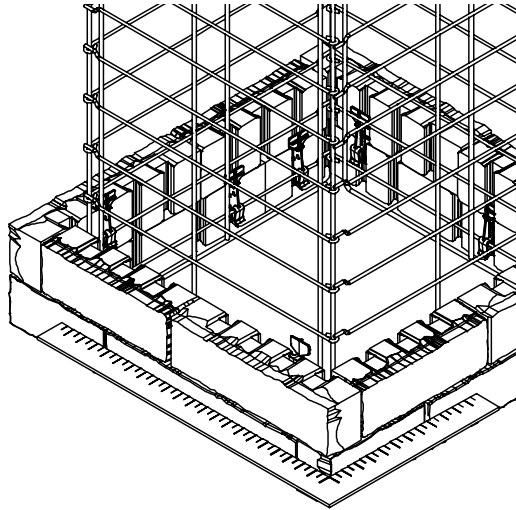

Ensure that the upper part of each connector is firmly in place behind the veneer unit, since it will serve as a support for the unit which will be installed above it.

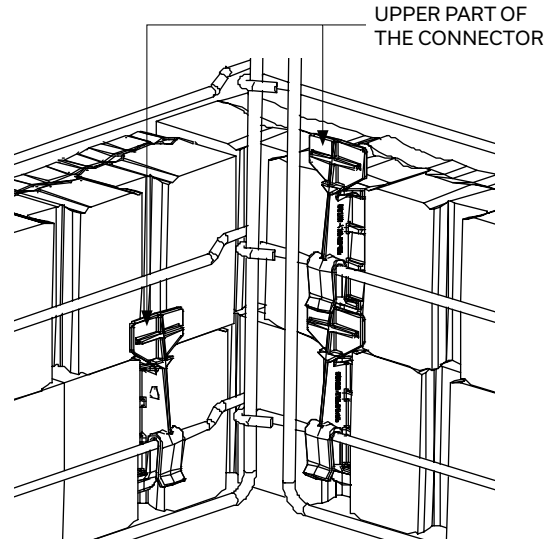

This is the recommended installation procedure for building the first four rows of a pillar. It makes optimal use of the veneer formats within a pallet: 16 regular veneers and 16 veneers with a texture end.

Repeating this pattern two more times will build a pillar with 12 rows and a height of 42 1/2 inches.

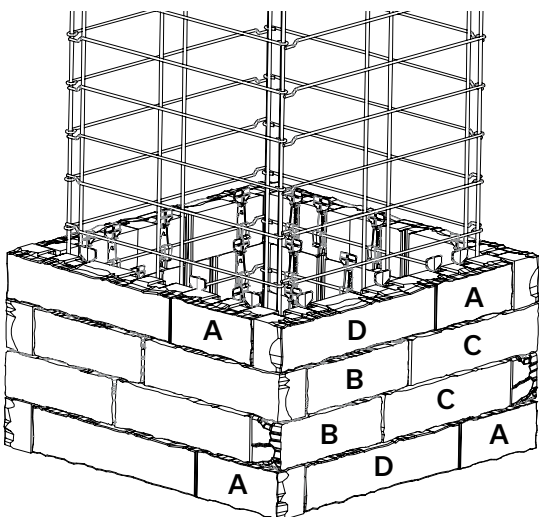

CUTTING INSTRUCTION OF PILLAR GRID

To build a pillar which is shorter than 1067 mm - 42 in., simply cut away the excess portion of the steel pillar grid with a grinder.

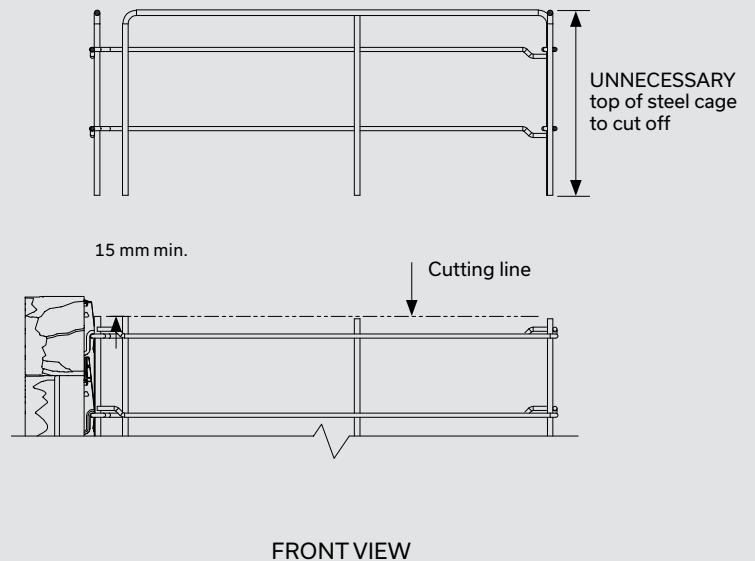

BUILDING PILLARS

LAFITT OR MELVILLE TANDEM 90 mm PILLAR ASSEMBLY (CONT'D)

A full steel pillar grid can be used to build a pillar with an overall height above ground, including the capping unit of 1067 mm - 42 in.

When the last row is reached, cut off the tops of the connectors with sheet-metal shears or twist them off by hand. Then install the capping unit on the pillar*, adhering it in place with glue.

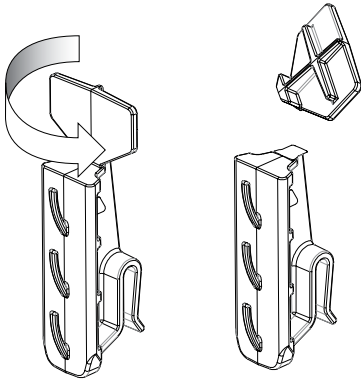
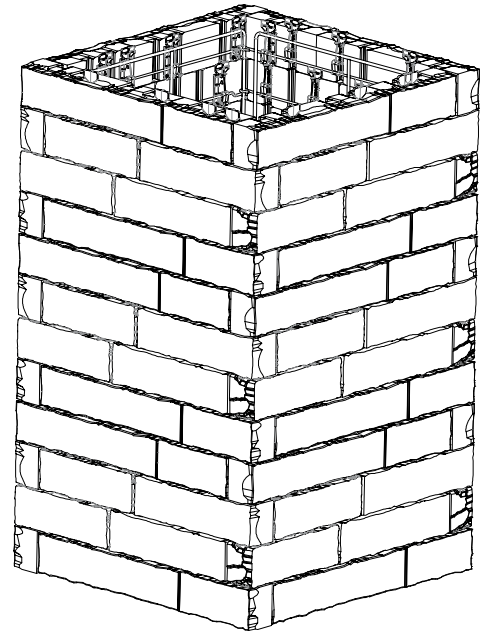

*** VERY IMPORTANT:** the capping unit must rest on the veneer units and not on the steel pillar grid.

LAFITT OR MELVILLE TANDEM PILLAR 90 mm AND 180 mm VENEER UNITS

When using 180 mm high veneer units, use four connectors as shown below, beginning with the two lower ones and ending with the two upper ones.

To integrate 180 mm units into a pillar, use only 180 mm E and F units with textured corners. Carefully place the veneer units so that the joints are staggered, and ensure that you place at least one 180 mm unit on each side of the pillar, and not more than two.

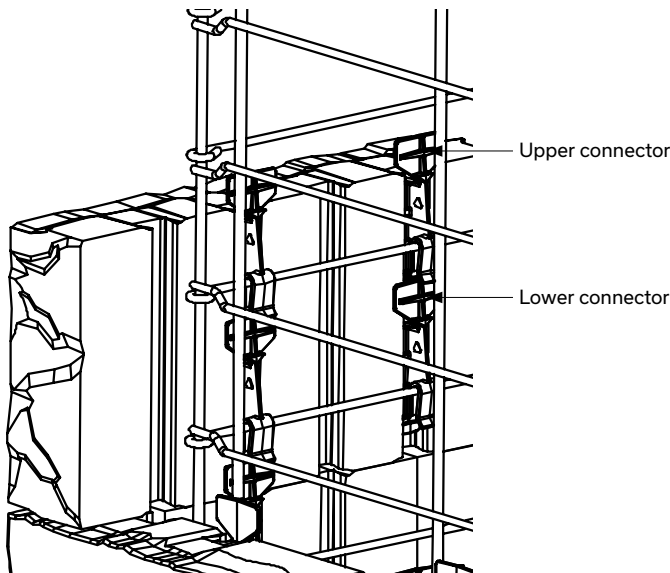

JOINING A DOUBLE-SIDED WALL TO A PILLAR

To join a double-sided wall to a pillar, you must cut the veneer unit for the pillar at every second row. Cut it at the centre of the dovetail recess.

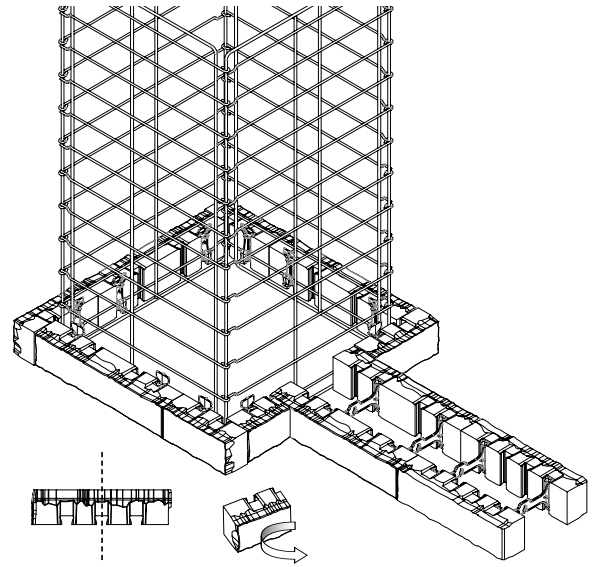

For the second row, run the unit across the double-sided wall.

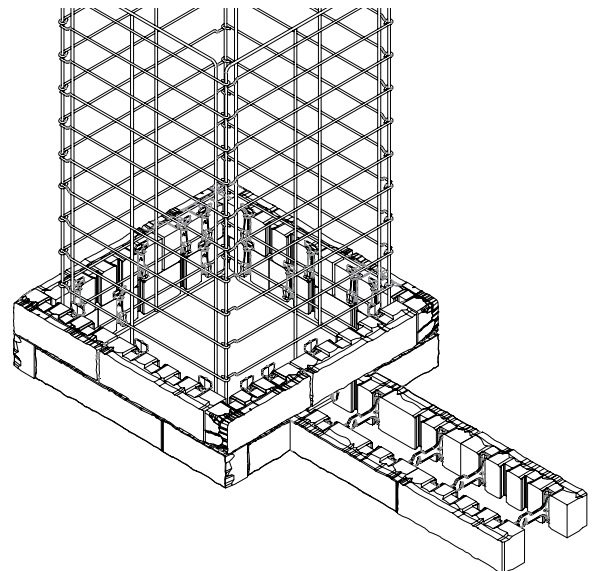

Begin the second row of the double-sided wall from the face of the pillar.

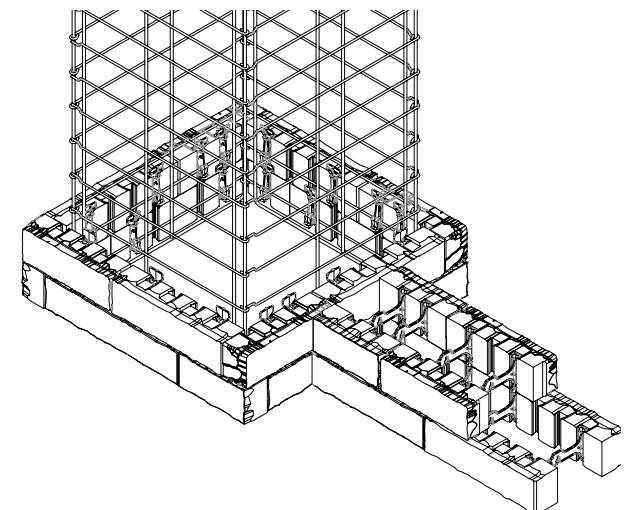

BUILDING PILLARS

LAFITT AND MELVILLE TANDEM PILLAR WITH STRUCTURAL UNITS

Two types of pillars can be built:

- > Lafitt Tandem
- > Melville Tandem

Pillars are built by placing Tandem units at 90° angles to create a square. Corners can then be completed by adding the appropriate textured veneer units. These veneers are attached using a corner connector as mentioned in the section on building a corner. It is advisable to glue each unit together for every course.

Maximum pillar height ranges from 1200 to 1500 mm - 4 to 5 ft. above ground level with a minimum buried depth of 150 mm - 6 ft. Capping is completed using a natural stone glue on last row. See table.

The predetermined installation patterns which are provided are intended to facilitate the building of each type of pillar. They also permit the optimal use of the different Tandem units and the textured veneer units.

In all cases, it is important to avoid aligning vertical joints from one row to the next on all visible facades. For these reasons, some combinations should be avoided from row to another.

Note that for some combinations, you need to use a structural unit A cut in two and fitted together with the veneer units.

When a double-sided wall ends at a pillar, the pillar must be modified to ensure it is solidly embedded, as in the illustration shown here.

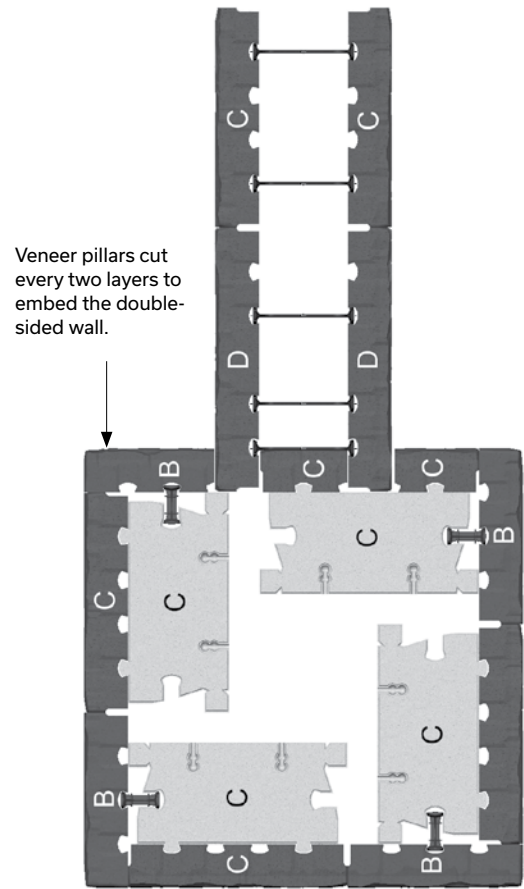

EXAMPLE OF EMBEDDING

90 PILLAR UNIT	MAXIMUM HEIGHT
670 x 670 mm 26 3/8 x 26 3/8 in.	1200 mm - 4 ft
737 x 737 mm 29 x 29 in.	1500 mm - 5 ft

BUILDING PILLARS

LAFITT AND MELVILLE TANDEM PILLAR WITH 90 mm UNITS

PILLAR

670 x 670 mm - 26 3/8 x 26 3/8 in.

1st ROW

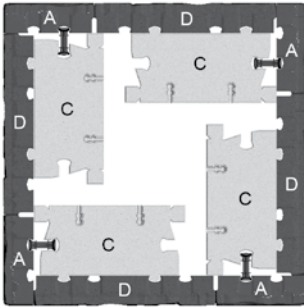

Veneer A with textured end

2nd ROW

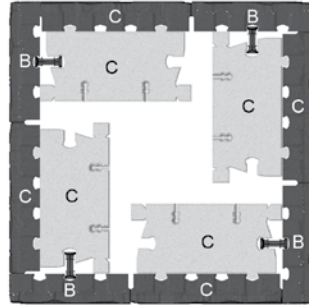

Veneer B with textured end

3rd ROW

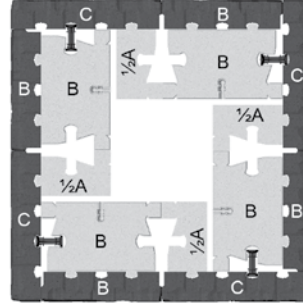

Veneer C with textured end

4th ROW

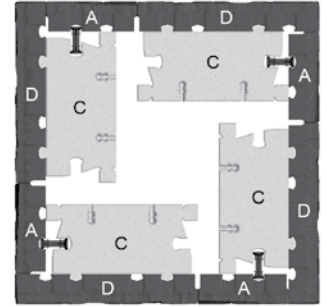

Veneer D with textured end

BUILDING PILLARS

LAFITT AND MELVILLE TANDEM PILLAR WITH 90 mm UNITS (CONT'D)

PILLAR

737 x 737 mm - 29 x 29 in.

1st ROW

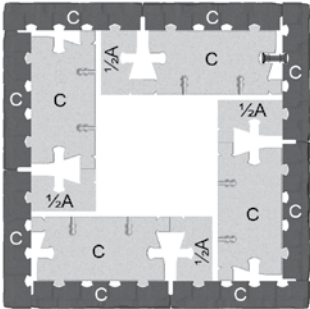

Veneer C with textured end

2nd ROW

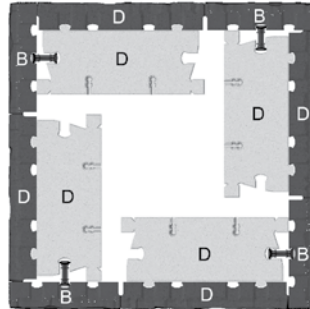

Veneer B with textured end

3rd ROW

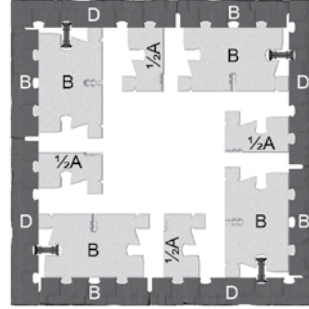

Veneer D with textured end

4th ROW

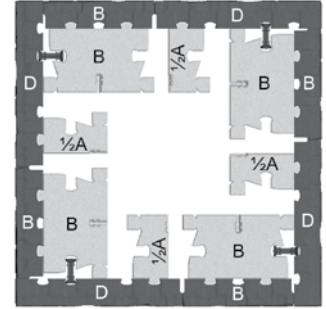

Veneer D with textured end

5th ROW

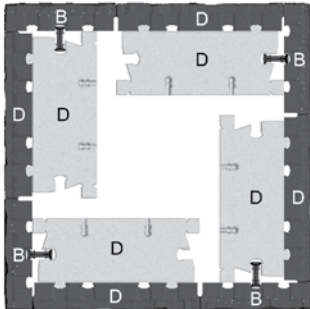

Veneer B with textured end

6th ROW

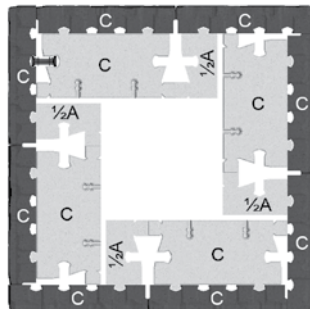

Veneer C with textured end

7th ROW

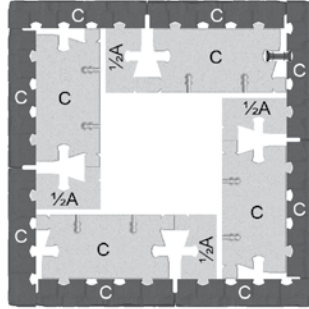

Veneer C with textured end

8th ROW

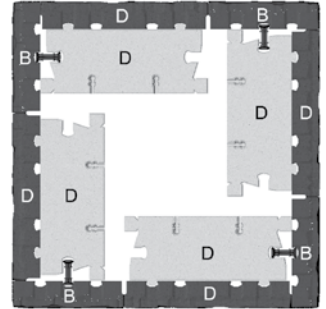

Veneer B with textured end

9th ROW

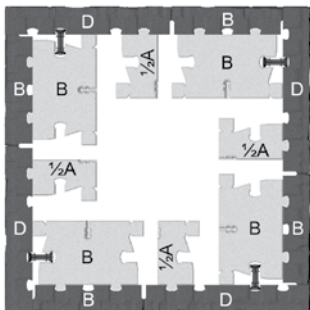

Veneer D with textured end

LAYING PATTERN

TANDEM 90 mm PILLAR
First 9 rows (over starter units)
810 mm - 31 7/8 in.

LEGEND

- D** Veneer D with textured end
- C** Veneer C with textured end
- B** Veneer B with textured end
- A** Veneer A with textured end

Installation pattern to repeat up to
DESIRED HEIGHT

D	B	D	9 th ROW
B	D	B	8 th ROW
C	C	C	7 th ROW
C	C	C	6 th ROW
B	D	B	5 th ROW
D	B	D	4 th ROW
D	B	D	3 rd ROW
B	D	B	2 nd ROW
C	C	C	1 st ROW

Outdoor Living Components

CONSTRUCTION OF OUTDOOR LIVING COMPONENTS WITH THE TANDEM MODULAR GRID (GENERALITY)



The Tandem system allows you to install different outdoor living components such as outdoor kitchens (barbecue, fridge, bar), patio furniture (bench and table), flower box, outdoor gas fireplace, privacy wall, fencing and deck skirting.

Indeed, you can easily build all these features by using the Tandem modular grid.

Our system has multiple benefits:

- > Provides a unified look for all the features of the landscaping design
- > Provides a durable, economical and maintenance-free solution
- > Offers great flexibility and unrestricted creativity regarding the configuration and size of components to be constructed
- > Offers a solution to difficult issues (e.g. deck skirting)
- > Eliminates the use of cementitious products (mortar)

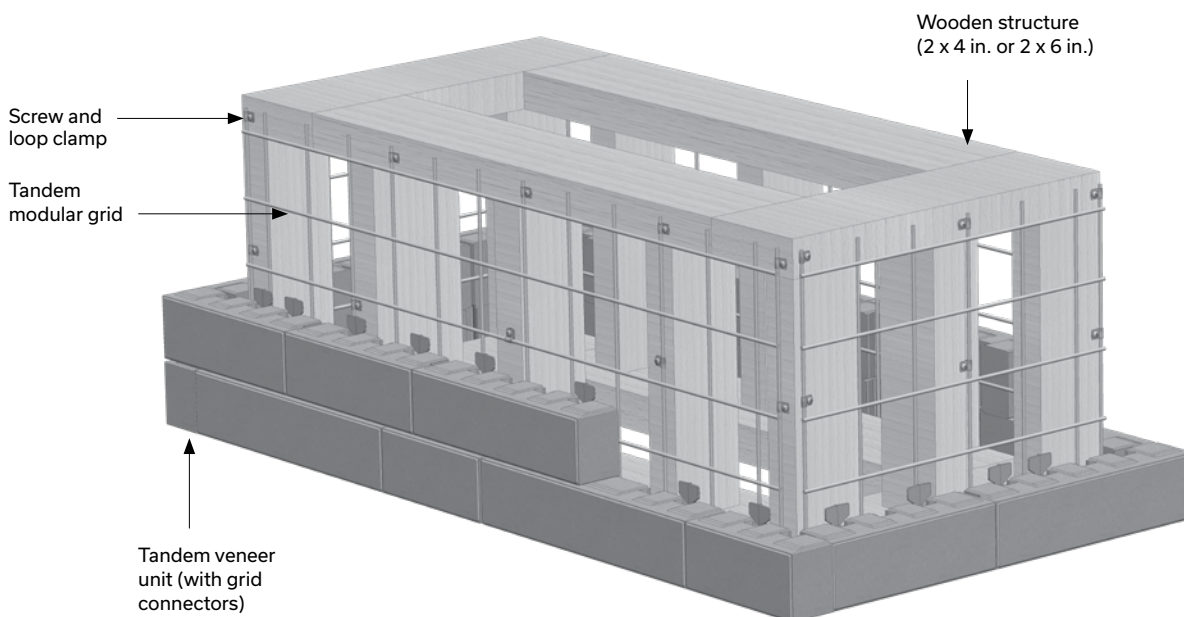

BASIC PRINCIPLES

A set of Tandem modular grids is attached to a structure of treated wood to which are attached Tandem veneer units (Lafitt or Melville). Since veneer units are manufactured in multiples of 67 mm, the overall dimensions of outdoor units should always be a multiple of 67 mm in order to avoid cuts. The wooden structure should be built taking into account the modular design of Tandem veneers. The same applies to the height, which must be a multiple of 90 mm. The item is finished off with an appropriate capping unit. You can construct a range of outdoor units of various dimensions.

MAIN COMPONENTS OF THE SYSTEM

- > Tandem modular grid, 720 x 1080 mm - 28 x 42 1/2 in., including stainless steel screws and loop clamps for fastening. A modular grid covers a facing surface of 0.78 m² - 8.40 sq.ft.). Each modular grid includes a kit of 60 connectors, 10 x 1 1/4 in. screws and 10 loop clamps.
- > Tandem veneer units (Lafitt or Melville)
- > Galvanized shelf angle (for deck skirting, privacy walls and fences) 64 x 64 x 2439 mm - 2 1/2 x 2 1/2 x 8 ft. (min 10 gauge, Z275 G90 galvanized steel, ASTM A653 Grade 33)
- > Permacon concrete capping unit (Lafitt, Melville et Mondrian Plus along with Celtik capping)

OTHER COMPONENTS NOT SUPPLIED BY PERMACON

- > Treated Wood: 2 x 4, 2 x 6 and 2 x 8 boards, 4 x 4 or 6 x 6 posts, 4 x 8 plywood sheets (all wood should be treated against rot and must be category S-P-F #1 or better). Refer to the various suppliers' specific application sheets for details.
- > Fiber cement panels 1220 x 2240 x 12 mm (48 x 96 x 1/2 in.)
- > # 10 screws of varying lengths, nuts, bolts and washers where required, all in stainless steel. It is not recommended to use treated wood screws (green ceramic) or metal plated screws (zinc, copper or other)
- > Hilti Kwik Bolt-type anchors (for concrete deck skirting)
- > Simpson Strong-Tie-type hardware for construction of wood frame for deck
- > Custom countertops made of granite, quartz, marble and natural stone as alternatives to concrete tops

CONSTRUCTION OF OUTDOOR LIVING COMPONENTS WITH THE TANDEM MODULAR GRID

WOOD FRAMING

You must always take the modular design of Tandem Veneers into account when constructing wood framing. The overall dimensions of outdoor units must always be a multiple of 67 mm in length and width and 90 mm in height. When installing the framing, remember that grids need a 16 mm - 3/8 in. space between the veneer and the frame.

Bearing this in mind, the following tables show detailed measurements for the framing of units. These tables are very useful for quickly calculating the actual dimensions of the wood framing and the unit to be constructed to build the component without any veneers cut.

**TABLE OF COMPONENTS AND WOOD FRAME DIMENSIONS
BASED ON THE MODULAR FORMAT OF VENEERS**

DIM A (mm)	DIM A (in.)	DIM B (mm)	DIM B (in.)
201	7 15/16	35	1 3/8
268	10 9/16	102	4
335	13 3/16	169	6 5/8
402	15 13/16	236	9 5/16
469	18 7/16	303	11 15/16
536	21 1/8	370	14 9/16
603	23 3/4	437	17 3/16
670	26 3/8	504	19 13/16
737	29	571	22 1/2
804	31 5/8	638	25 1/8
871	34 5/16	705	27 3/4
938	36 15/16	772	30 3/8
1005	39 9/16	839	33 1/16
1072	42 3/16	906	35 11/16
1139	44 13/16	973	38 1/4
1206	47 1/2	1040	40 15/16
1273	50 1/8	1107	43 9/16
1340	52 3/4	1174	46 1/4
1407	55 3/8	1241	48 7/8
1474	58 1/16	1308	51 1/2
1541	60 11/16	1375	54 1/8
1608	63 5/16	1442	56 3/4
1675	65 15/16	1509	59 3/8
1742	68 9/16	1576	62 1/16
1809	71 1/4	1643	64 5/8
1876	73 7/8	1710	67 5/16
1943	76 1/2	1777	69 15/16
2010	79 1/8	1844	72 5/8
2077	81 3/4	1911	75 1/4
2144	84 7/16	1978	77 7/8
2211	87 1/16	2045	80 1/2
2278	89 11/16	2112	83 1/8
2345	92 5/16	2179	85 3/4
2412	94 15/16	2246	88 7/16
2479	97 5/8	2313	91 1/16
2546	100 1/4	2380	93 11/16
2613	102 7/8	2447	96 5/16
2680	105 1/2	2514	99

TANDEM VENEERS - MODULAR DESIGN

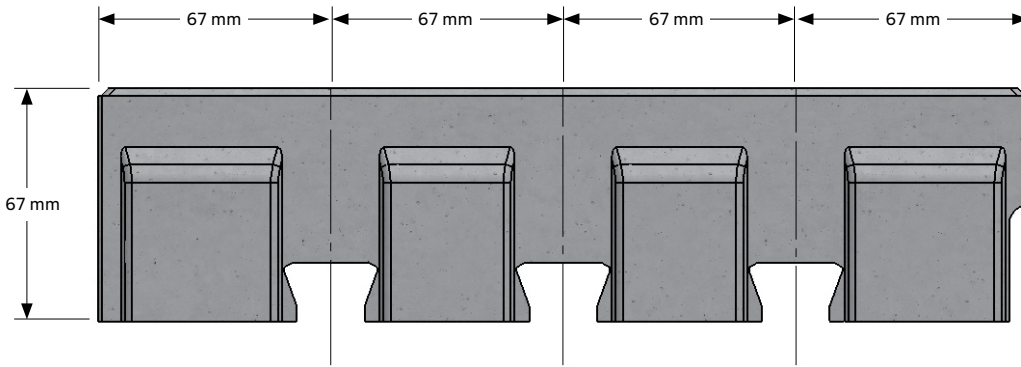

TYPICAL COMPONENT - PLAN VIEW

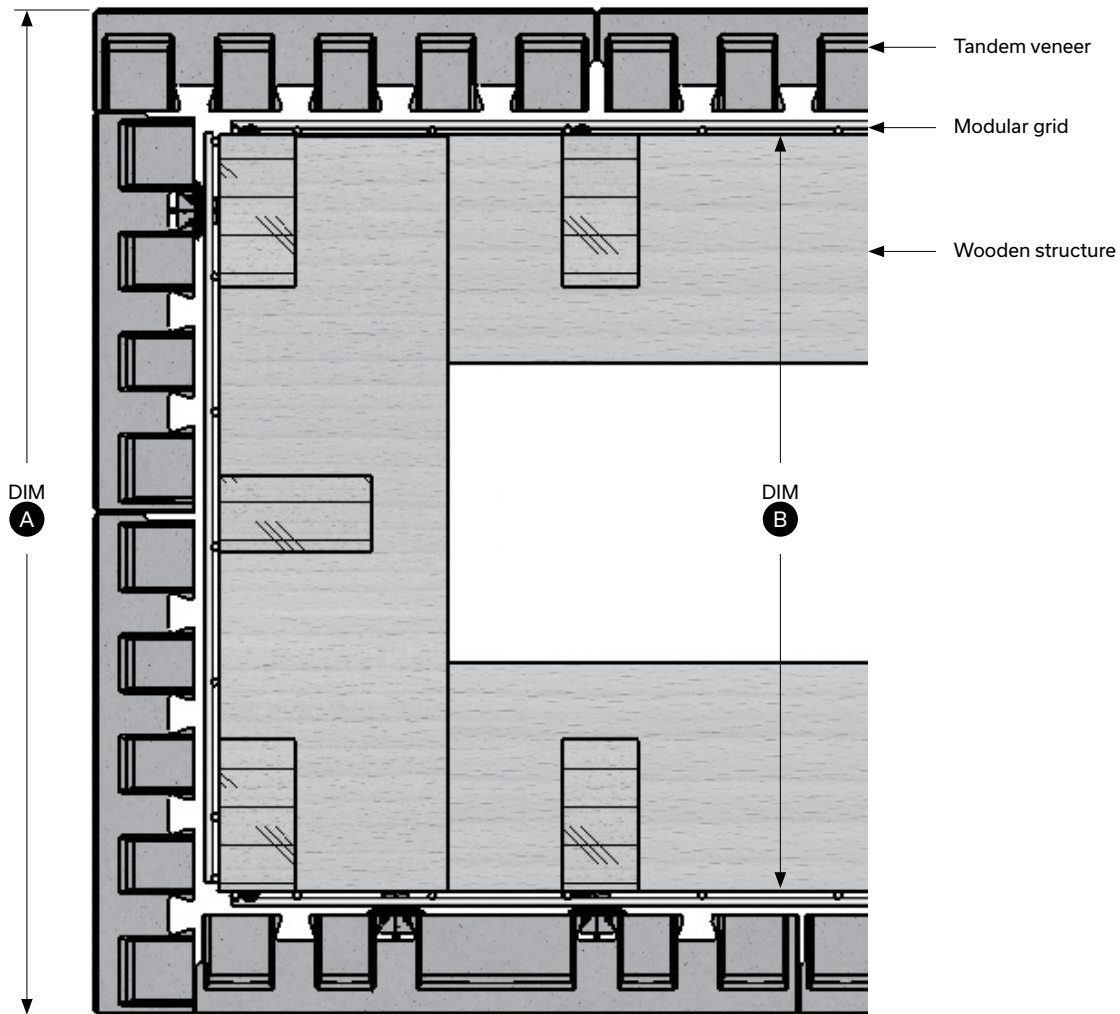

TYPICAL COMPONENT - SIDE VIEW

**HEIGHT OF COMPONENTS AND WOOD FRAME
ACCORDING TO THE MODULAR DESIGN
OF 90 mm VENEER UNITS**

NUMBER OF ROWS	HEIGHT (mm)	HEIGHT (in.)
2	180 mm	7 1/16
3	270 mm	10 5/8
4	360 mm	14 3/16
5	450 mm	17 11/16
6	540 mm	21 1/4
7	630 mm	24 13/16
8	720 mm	28 1/3
9	810 mm	31 1/8
10	900 mm	34 5/8
11	990 mm	39
12	1080 mm	42 1/2

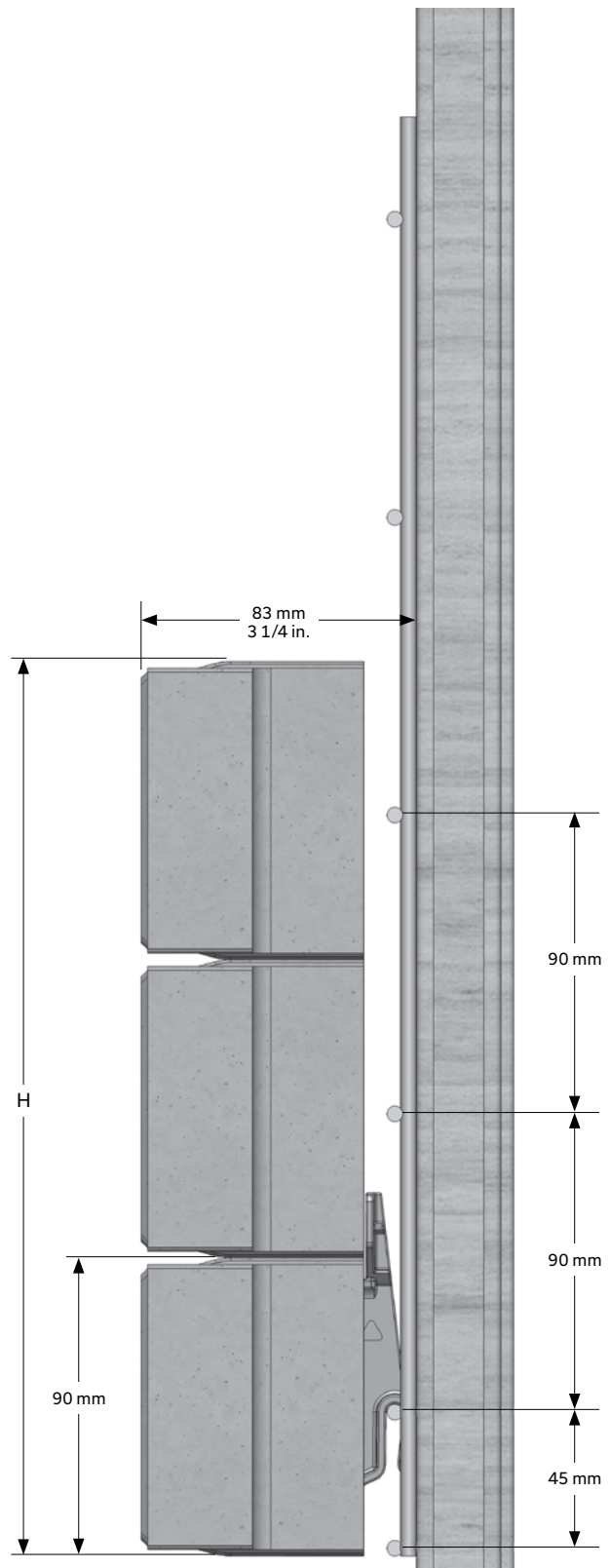

TYPICAL COMPONENT - FRONT VIEW

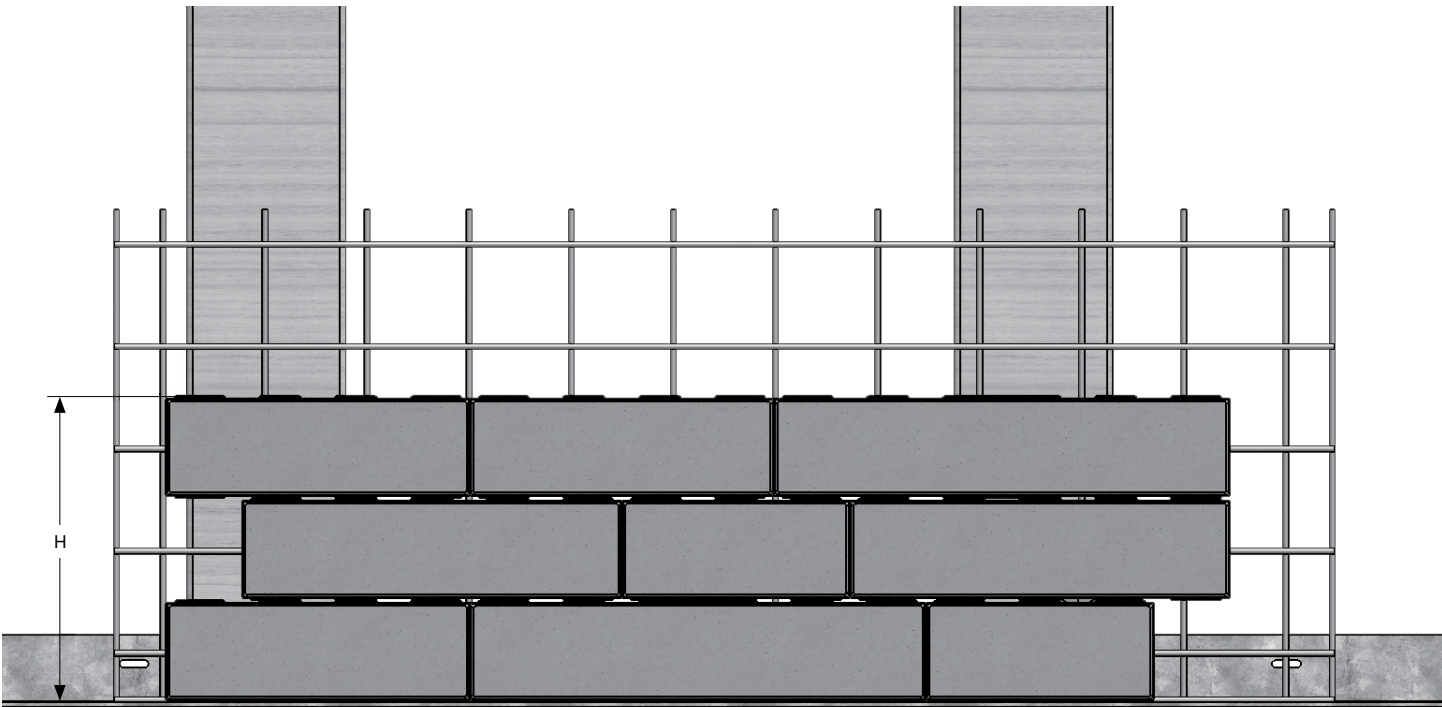

TANDEM MODULAR GRID - DETAIL 1

It is important to note that the units to be constructed must always be straight and have corners (inner and outer) forming a 90° angle. Therefore, making a corner is a common element in all construction plans. You can also refer to the plan view detail (page 44) to see how to make a 90° corner, taking into account the modular design of Tandem veneers and grids. When building the wood frame, keep in mind that you have to install Tandem grids. The flexibility of the grid means that you can install it in either direction, horizontally or vertically.

You have to cut the grids when the unit you're building is smaller in size (height or length) than a complete grid of 28 in. or 42 1/2 in. It may be helpful to decide the direction of the grid so as to minimize cuts. To cut a grid, use any suitable tool like a grinder or bolt cutters.

To avoid making cuts in the veneers, simply follow the dimensions based on the modular design of the veneers shown in the previous tables.

DETAIL 1

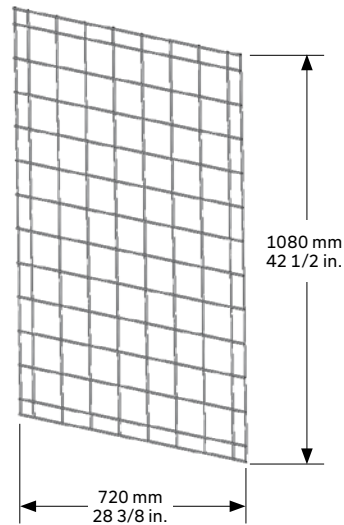

VERTICAL INSTALLATION

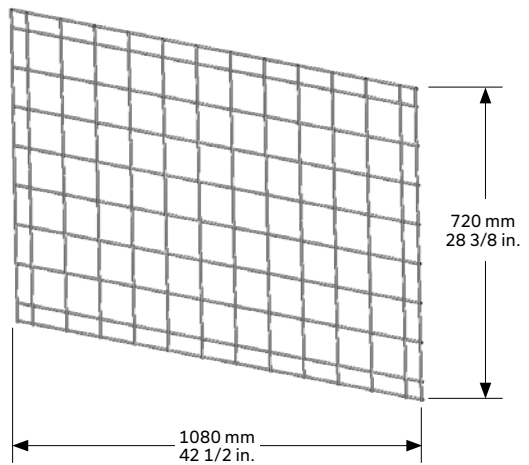

HORIZONTAL INSTALLATION

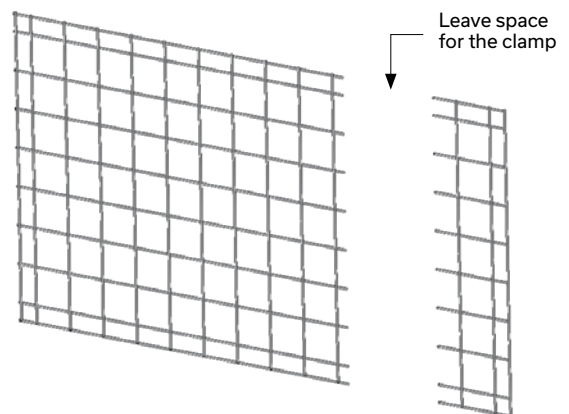

TANDEM MODULAR GRID - DETAIL 2

The grid is attached with the loop clamps and screws supplied. Simply place the loop clamps around the vertical rods of the grid and then insert a screw into the wood frame. There are 10 loop clamps per Tandem grid.

To secure a grid, the loop clamps should be evenly positioned, starting with the edge of the grid and moving towards the center. To ensure the solidity of the grid, use approximately one fastener (screw and loop clamps) per square foot of grid or 10 fasteners per square meter. To attach a grid to the wood frame, the vertical rods must be placed directly against the structure.

Since the metal rods of the grids are spaced every 90 mm, it's helpful if the intermediate posts of the wood framing are multiples of 90 mm. This will increase the available attachment area for the grid. A continuous attachment area like plywood sheeting can also be used to provide a larger surface for attaching the Tandem grid.

When a unit requires more than one grid either horizontally or vertically, they should be installed one after the other in both directions.

DETAIL 2

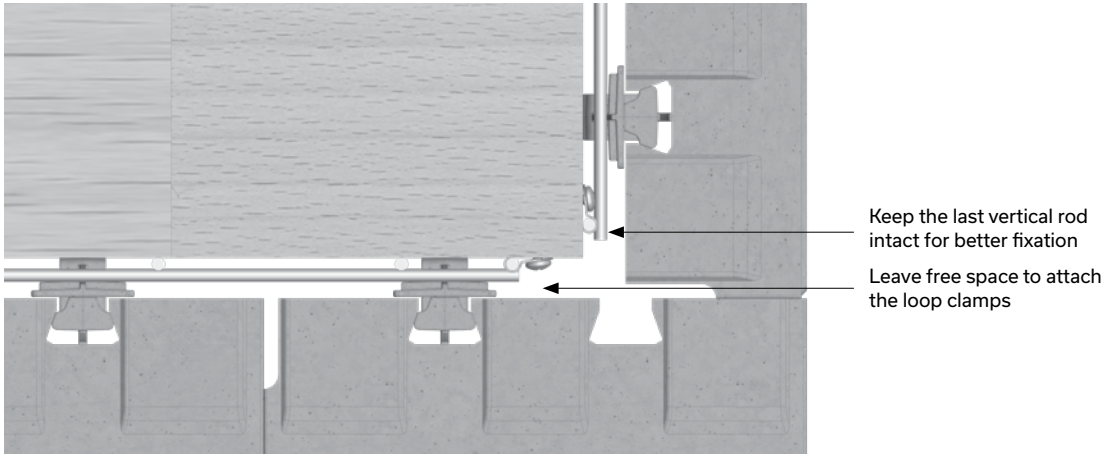

MODULAR GRID CUTTING INSTRUCTIONS (PLAN VIEW)

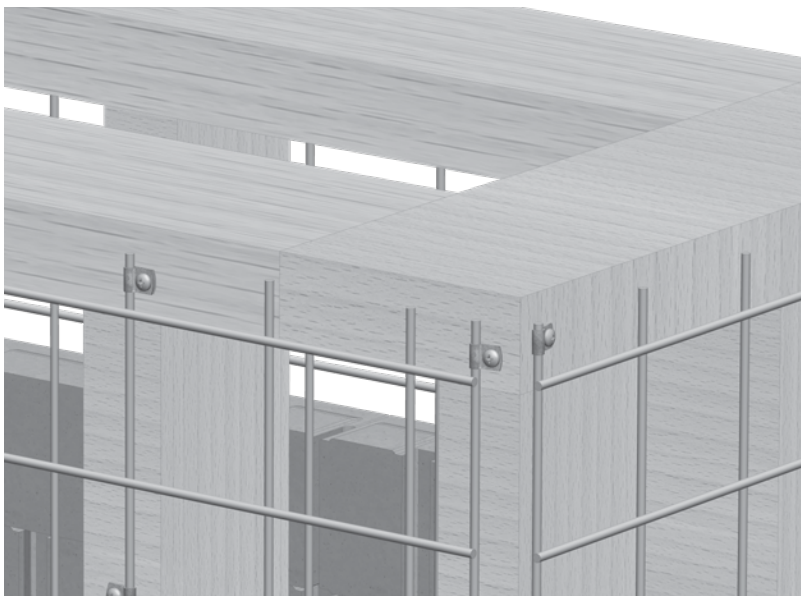

ISOMETRIC VIEW

TANDEM VENEERS

When the grids have been installed, just insert the veneers into the unit using the connectors specially designed for this purpose. We recommend using 2 connectors per veneer for a solid job, but sometimes a connector cannot be inserted due to the geometry of the grid. You must then secure the veneer by gluing it to surrounding veneers with Techniseal concrete adhesive.

Normally, for a standard project, all formats of the veneer units are used randomly. As for retaining walls, always keep in mind the principle of staggering the vertical joints from one row to another. For the corners, you need corner units just like constructing a pillar with steel grids (see BUILDING PILLARS section). But it should be noted that sometimes the construction of a short unit requires a larger quantity of the same format veneers, especially corner units (for Lafitt Tandem, the amount of veneer corner units is in a proportion of about 1/2 of a pallet. For Melville Tandem, all veneer units have a textured corner. It is important to check this when calculating the quantity so as to have enough of the appropriate veneers on hand.

It is also possible to use 180 mm veneers when constructing a unit, the same as for a retaining wall or a column.

Stacking position on pallets (with a textured end)

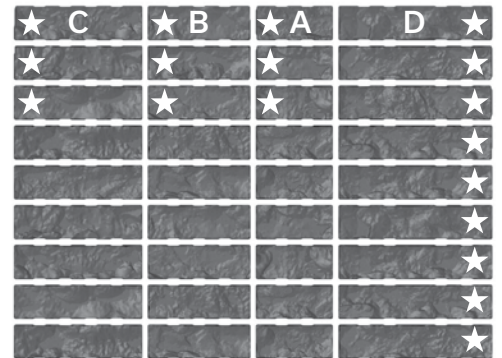

LAFITT TANDEM - UNITS 90

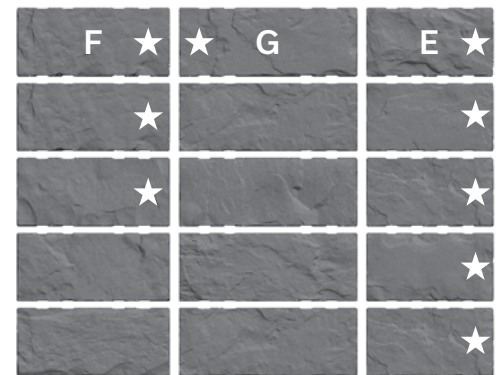

LAFITT TANDEM - UNITS 180

BRACING

Some items require bracing panels like plywood sheeting, especially for privacy walls, fencing and deck skirting. These panels are needed to strengthen the unit to withstand stress such as wind and to limit distortion under regular loads.

EXAMPLE OF BRACING (privacy wall)

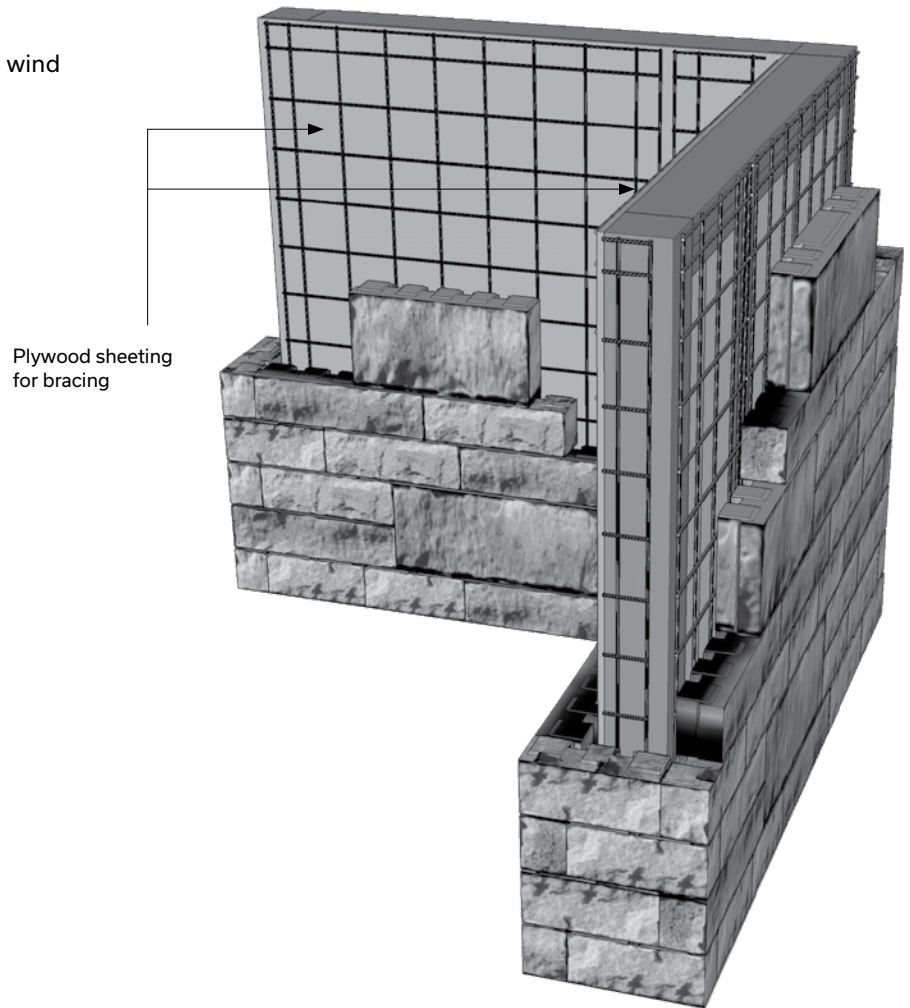

Other units require the installation of fiber cement panels for heat insulation (barbecues and outdoor gas fireplaces) or as protection against moisture (flower boxes). In these situations, we recommend fiber cement panels of a minimum thickness of 12 mm - 1/2 in.

EXAMPLE OF A HEAT PROTECTION SET-UP

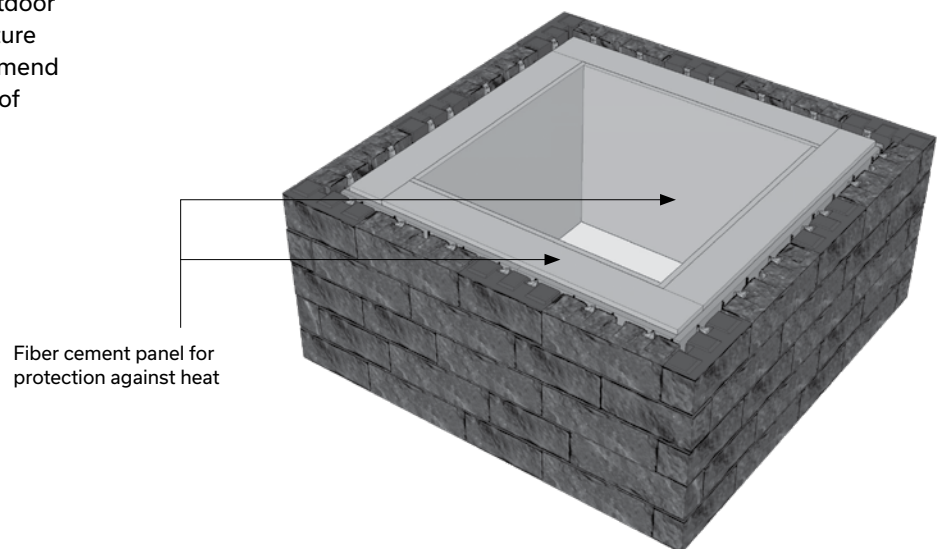

BASE SUPPORT FOR OUTDOOR UNITS

Outdoor units like a bench, flower box or outdoor fireplace can usually be built on a base of concrete foundation (starter units) or placed directly onto concrete pavers. A granular base of compacted crushed stone should be laid before the foundation. However, we recommend that long or heavy units be supported on a concrete slab (minimum thickness of 150 mm or 6 in. We also recommend that units like barbecues or tables with a single granite, quartz or marble top over their entire surface be supported on a reinforced concrete slab to prevent the top from breaking if the ground shifts. In each case, a compacted granular base should underlie the concrete slab.

CROSS SECTION - COMPONENTS SUPPORTED ON A CONCRETE SLAB

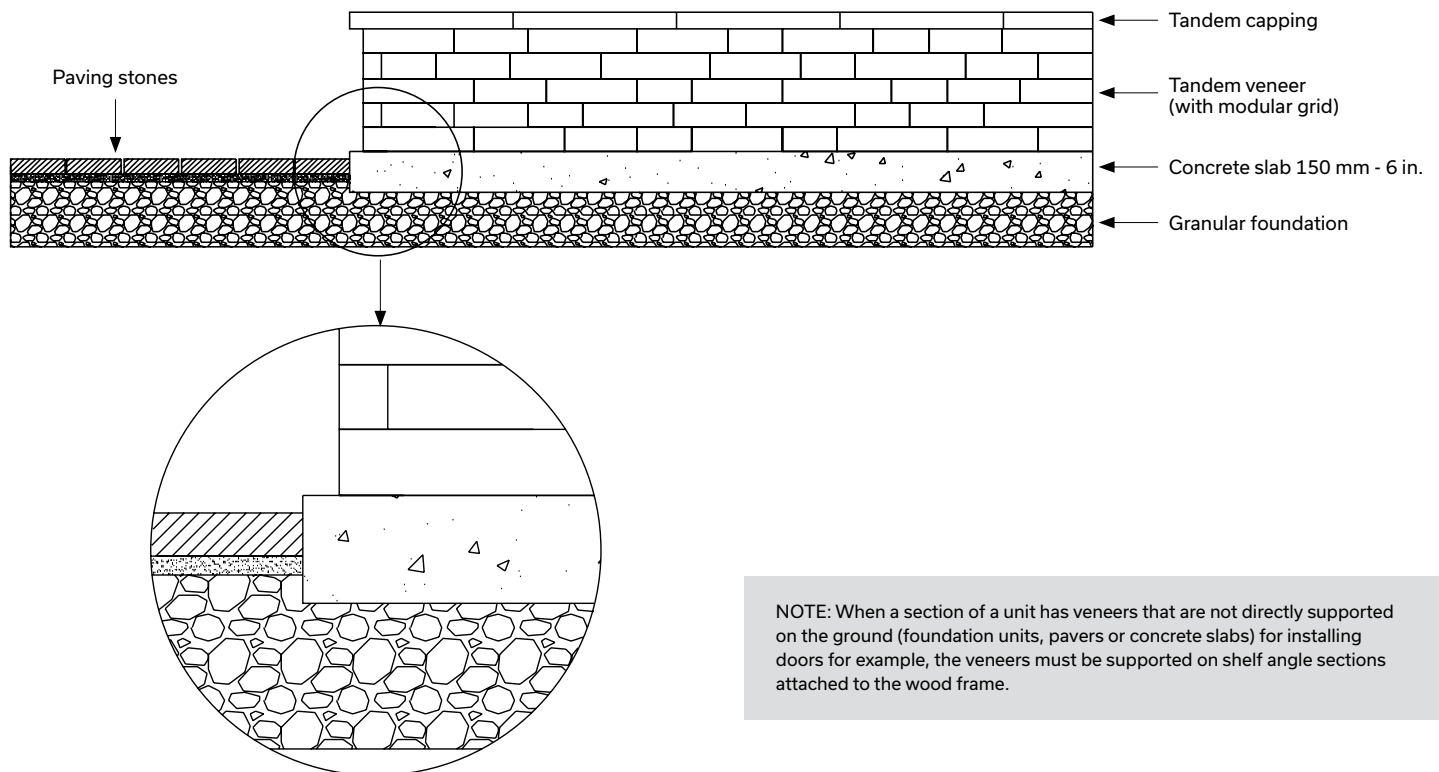

NOTE: When a section of a unit has veneers that are not directly supported on the ground (foundation units, pavers or concrete slabs) for installing doors for example, the veneers must be supported on shelf angle sections attached to the wood frame.

CONSTRUCTION LUMBER

Building the different units in this guide requires construction lumber for the framing: 2 x 4, 2 x 6 and 2 x 8 boards, 4 x 4 and 6 x 6 posts and plywood sheets. We recommend that all wood used outdoors be treated against rot according to established procedures approved by Health Canada. You should use S-P-F #1 or #2 wood or better. This type of wood usually has a minimum life of 15 years without maintenance in normal outdoor conditions.

NOTE: Wooden components that have been cut or sawed should be treated with an anti-rot product.

COMPLIANCE WITH CONSTRUCTION STANDARDS

In all circumstances, units to be constructed must always comply with the requirements of the National Building Code (version specific to your region) and local municipal bylaws and regulations.

Building an Outdoor Gas Fireplace

CONSTRUCTION OF AN OUTDOOR GAS FIREPLACE

Note that the only type of fireplace recommended for this type of construction is a propane gas or natural gas fireplace. A wood fireplace is not permitted.

Construction should begin with laying a solid foundation that is leveled, compacted and well drained.

The wood framing must be built according to the type of fireplace chosen. Dimensions are calculated using the data on shop drawings provided by the fireplace manufacturer. It may be necessary to add some extra parts like plywood shims for adjusting to the exact modular dimensions of the fireplace (Tandem modular veneers according to the wood frame design).

It is essential to install heat insulation. A fiber cement panel of a minimum thickness of 12 mm - 1/2 in. is recommended for adequate protection. The panels must be installed all around the heating element (burner).

You must also plan to install conduits in the ground for gas pipes and for electric cables if required.

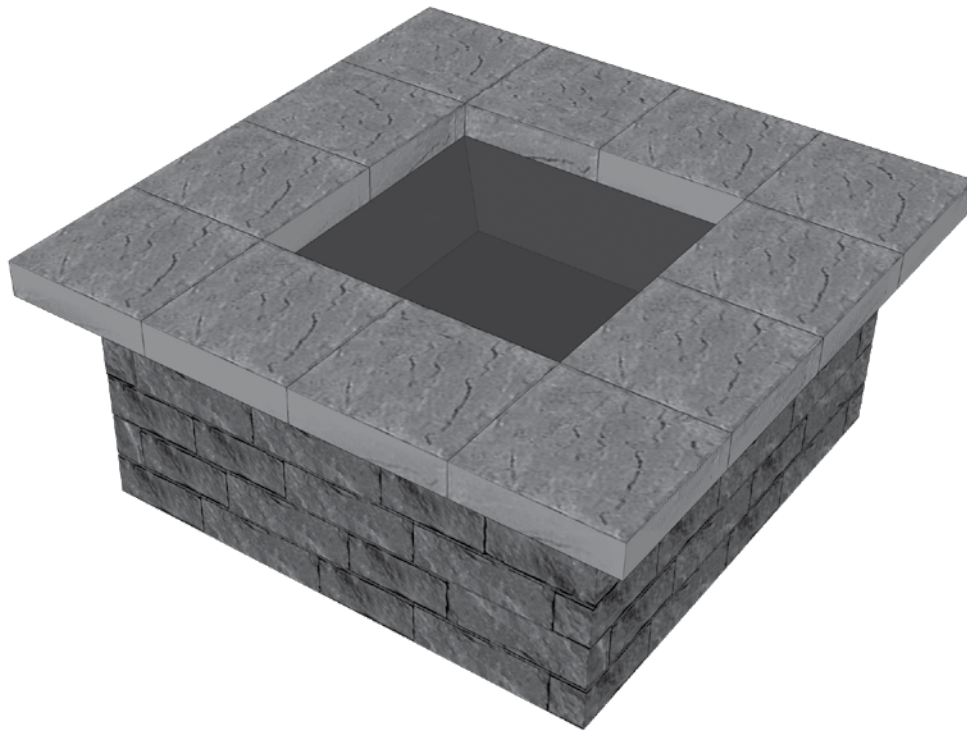

Building an Outdoor Kitchen

BUILDING AN OUTDOOR KITCHEN - BARBECUE, REFRIGERATOR, BAR

The wood frame must be constructed according to the type of barbecue chosen. Dimensions are calculated using data on the shop drawings provided by the barbecue manufacturer. Additional accessories such as a fridge or integrated cabinet doors are also possible. Naturally, you have to plan on adding pieces of wood to attach accessories to the wooden structure, like a frame in the case of doors. When purchasing supplies, you will usually find moldings to finish the edges of the various units.

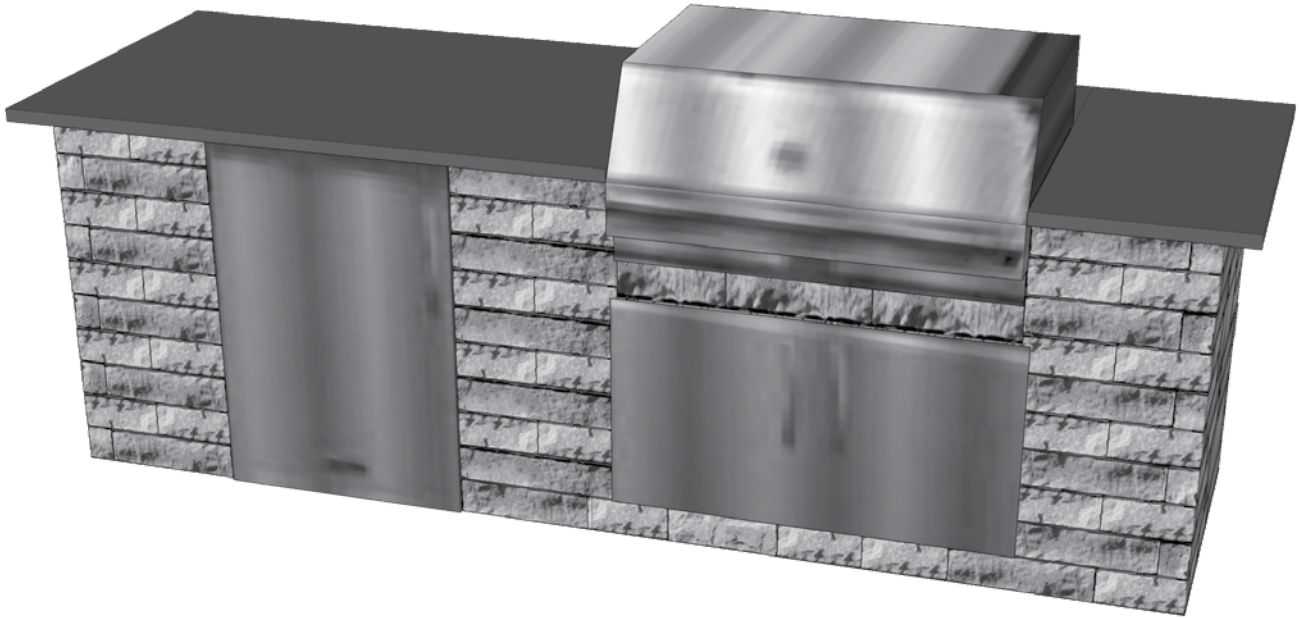

It is essential to install protection from heat and sparks. A fiber cement panel of a minimum thickness of 12 mm - 1/2 in. or a double-skinned steel section if provided by the BBQ manufacturer is recommended for adequate protection. The panels must be installed all around the heating element (burner).

Finish off with concrete capping or panels of granite, quartz, marble or natural stone. The panels must be made to measure by specialized companies. You must make special provisions for handling and installation to avoid possible breakage. The panels are attached on top of the plywood with silicone adhesive to prevent movement.

Provide adequate means for venting gases when constructing the barbecue. (Refer to the barbecue manufacturer's recommendations for the position and size of the ventilation grid required).

You should also plan to install conduits for gas pipes and electric cables. The conduits may in certain cases be installed in the ground.

Building Patio Furniture

BUILDING PATIO FURNITURE (TABLE AND BENCH) AND FLOWER BOX

TABLE

You can make a table by building a Tandem unit (grid and veneers) to form the base and then adding a tabletop. The tabletop can be wood, granite, quartz, marble or natural stone.

Dimensions may vary. It is essential to leave a minimum space between the table edge and the base. At least 460 mm - 18 in. is needed for leg room.

Granite, quartz or marble tabletop: the tabletop must be attached to the veneers with a silicone adhesive. We recommend that a tabletop resting on a Tandem unit be made from a single piece to increase rigidity and stability. This allows you to avoid adding a metal fastener to secure the tabletop to the structure for increased stability and extra protection where necessary. For very large tabletops, it is recommended to install steel supports (angles) to better stabilize the whole unit. You should enquire from the tabletop supplier what are the optimal sizes and thicknesses for stability and security and to avoid possible breakage.

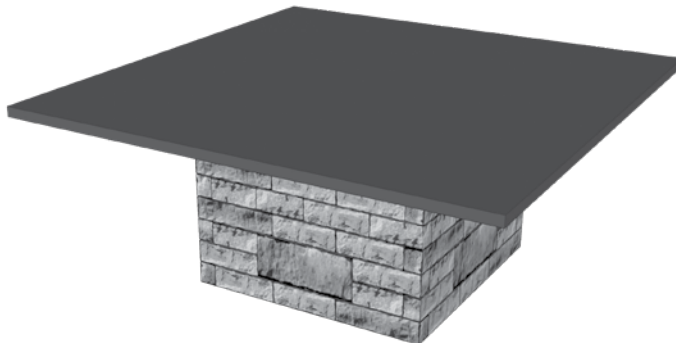

BENCH

You can make a bench by building a structure for the base and simply adding a concrete capping unit for the seat. Bench dimensions can vary, but it may be helpful to make your decision based on available capping units in order to avoid cuts. For a typical bench, the capping will be of the Melville Plus type.

Bench minimum width is 21 in.

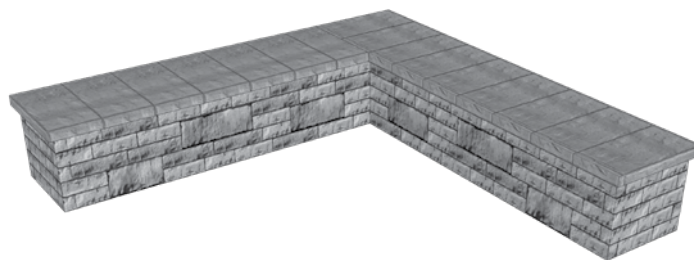

FLOWER BOX

It is recommended to install a fiber cement panel and a geotextile membrane to protect the wood against deterioration caused by vegetable and mineral materials (plants and soil). You should provide water drainage when building the structure.

For the capping, use the following products for retaining walls: Mondrian 50, Lafitt Plus Tandem, Melville Plus and Celtik capping.

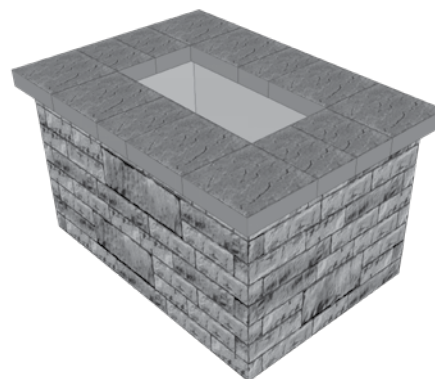

Building Privacy Walls and Fences

CONSTRUCTION OF A PRIVACY WALL AND A FENCE

When building a fence or when wanting to hide or conceal various pieces of equipment (e.g. pool filter, heat pump) or utility items (e.g. trashcans or storage bins), the Tandem modular grid system is just what you need.

Fencing is mostly built with treated wood posts (structural, select quality) supported by cast-in-place concrete foundations (Sonotubes) for the main structure. An intermediate structure in treated wood boards is then installed between the posts to attach the fence components of Tandem modular grids and veneers. A shelf angle is fixed to the base of the structure to provide continuous support for the weight of the veneers. The shelf angle (2 1/2 x 2 / 12 x 8 in.) is attached to the base of the structure (wood poles and boards forming the stringer) with suitable screws (#10 x 3 1/2 in.) every 200 mm - 8 in. The shelf angle can be cut to the size of the unit under construction.

The wooden structure between the posts, combined with the shelf angle, supports the weight of the walls and transfers it to the foundations. Fences and privacy walls must rest on pillars (Sonotubes) and concrete foundations to transfer the weight of the walls to the ground. The foundations are also necessary to prevent the walls from collapsing due to the force of the wind.

The dimensions of the foundations in this guide were calculated to respect the weight-bearing capacity of the soil and to limit irregular subsidence that could lead to distortions in the wall. Calculations were made for soil conditions of low weight-bearing

capacity. For different soil conditions, we recommend consulting a qualified engineer. The foundation must be built to withstand local frost conditions. The depth of frost in this guide is 1.8 m - 6 in. The use of screw piles is not recommended for this type of application.

Privacy walls are made with the same main structure to which a perpendicular section is added to obscure non-aesthetic items.

The maximum height of a fence or a privacy wall is limited to 1.8 m - 6 ft.

The maximum length of a wall facade between posts is 2.4 m - 8 ft.

The unit can be built to display its aesthetic appearance on one side or both sides simultaneously.

The wood frame must integrate a bracing panel such as a sheet of 12 mm - 1/2 in. treated plywood to provide a continuous attachment area and stabilize the structure to withstand loads. To finish the walls, attach a cap on top of the wood frame, either in concrete (sizes to be decided on site) or metal (custom bent by a specialized company). Tandem Melville Plus steps can be used to finish the top of a fence or privacy wall.

The capping unit is fixed with a suitable concrete adhesive spread on the wooden structure and the top of veneers. It may be useful to fix the wooden structure to the concrete cap with a metal attachment to provide additional wind protection.

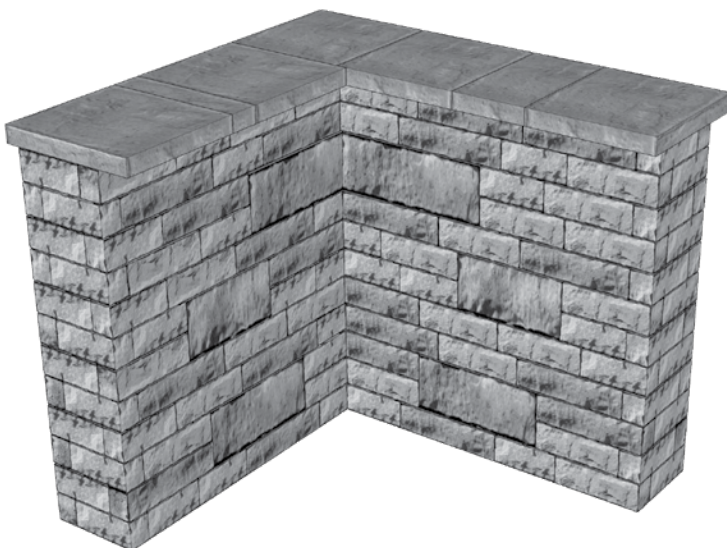

PRIVACY WALL

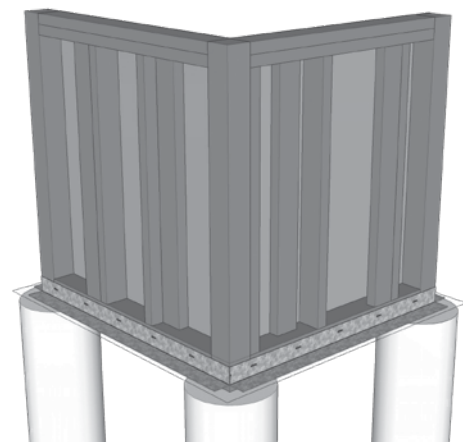

PRIVACY WALL on concrete pillar (Sonotube) - construction details of wooden structure

CONSTRUCTION OF OUTDOOR LIVING COMPONENTS WITH THE TANDEM MODULAR GRID

DESIGN DATA FOR FENCES

Since unit components will vary according to height from 0 to 1.8 m - 6 in., we present the main minimum requirements in table form.

FENCE WITH VENEER ON ONE SIDE					
FENCE HEIGHT	Ø PILASTER	FOOTING	EMBEDDING POST	POST	STRUCTURE
0 to 4 ft. OPTION 1	300 mm - 12 in.	Ø 600 mm - 24 in.	600 mm - 24 in.	4 x 4*	2 x 4
OPTION 2	300 mm - 12 in.	400 x 400 mm - 16 x 16 in.	600 mm - 24 in.	4 x 4*	2 x 4
OPTION 3	600 mm - 24 in.	N/A	600 mm - 24 in.	4 x 4*	2 x 4
4 to 5 ft. OPTION 1	300 mm - 12 in.	Ø 600 mm - 24 in.	600 mm - 24 in.	6 x 6**	2 x 6
OPTION 2	300 mm - 12 in.	400 x 400 mm - 16 x 16 in.	600 mm - 24 in.	6 x 6**	2 x 6
5 to 6 ft. OPTION 1	300 mm - 12 in.	Ø 600 mm - 24 in.	600 mm - 24 in.	6 x 6**	2 x 6
OPTION 2	300 mm - 12 in.	500 x 500 mm - 20 x 20 in.	600 mm - 24 in.	6 x 6**	2 x 6
FENCE WITH VENEER ON BOTH SIDES					
0 to 4 ft. OPTION 1	300 mm - 12 in.	Ø 600 mm - 24 in.	600 mm - 24 in.	4 x 4*	2 x 4
OPTION 2	300 mm - 12 in.	500 x 500 mm - 20 x 20 in.	600 mm - 24 in.	4 x 4*	2 x 4
4 to 5 ft. OPTION 1	300 mm - 12 in.	Ø 600 mm - 24 in.	600 mm - 24 in.	6 x 6**	2 x 6
OPTION 2	300 mm - 12 in.	500 x 500 mm - 20 x 20 in.	600 mm - 24 in.	6 x 6**	2 x 6
5 to 6 ft. OPTION 1	300 mm - 12 in.	Ø 600 mm - 24 in.	600 mm - 24 in.	6 x 6**	2 x 6
OPTION 2	300 mm - 12 in.	550 x 550 mm - 22 x 22 in.	600 mm - 24 in.	6 x 6**	2 x 6

N/A: Not Applicable * 4 x 4 SFP wood select structural ** 6 x 6 #1 SFP wood

It should be noted that the base of concrete pillars should normally have a wider section in the ground for a footing. The footing can take two shapes, square or round. There are round footings on the market, sold as BIGFOOT, which can be used for the construction of pillars. Square footings must be made on site with wooden formwork.

CONSTRUCTION OF OUTDOOR LIVING COMPONENTS WITH THE TANDEM MODULAR GRID

CAMOUFLAGE SCREEN DESIGN DATA

As the components of an element vary according to height (from 0 to 1.8 m - 6 ft.) we present in table form the main minimum criteria to consider.

WALL WITH VENEER ON ONE SIDE					
WALL HEIGHT	Ø PILASTER	FOOTING	EMBEDDING POST	POST	STRUCTURE
L1 and L2 configuration = 1.2 m - 4 ft.					
0 to 3 ft.	400 mm - 16 in.	N/A	600 mm - 24 in.	4 x 4*	2 x 4
3 to 6 ft. OPTION 1	600 mm - 24 in.	N/A	600 mm - 24 in.	6 x 6	2 x 6
OPTION 2	300 mm - 12 in.	400 x 400 mm - 16 x 16 in.	600 mm - 24 in.	6 x 6	2 x 6
OPTION 3	300 mm - 12 in.	Ø 600 mm - 24 in.	600 mm - 24 in.	6 x 6	2 x 6
L1 configuration = 2.4 m - 8 ft. and L2 = 1.2 m - 4 ft.					
0 to 4 ft. OPTION 1	600 mm - 24 in.	N/A	600 mm - 24 in.	4 x 4*	2 x 4
OPTION 2	300 mm - 12 in.	400 x 400 mm - 16 x 16 in.	600 mm - 24 in.	4 x 4*	2 x 4
4 to 5 ft. OPTION 1	600 mm - 24 in.	N/A	600 mm - 24 in.	6 x 6**	2 x 6
OPTION 2	300 mm - 12 in.	400 x 400 mm - 16 x 16 in.	600 mm - 24 in.	6 x 6**	2 x 6
OPTION 3	300 mm - 12 in.	Ø 600 mm - 24 in.	600 mm - 24 in.	6 x 6**	2 x 6
5 to 6 ft. OPTION 1	300 mm - 12 in.	400 x 400 mm - 16 x 16 in.	600 mm - 24 in.	6 x 6**	2 x 6
OPTION 2	300 mm - 12 in.	Ø 600 mm - 24 in.	600 mm - 24 in.	6 x 6**	2 x 6
WALL WITH VENEER ON BOTH SIDES					
L1 and L2 configuration = 1.2 m - 4 ft.					
0 to 4 ft.	400 mm - 16 in.	N/A	600 mm - 24 in.	4 x 4*	2 x 4
4 to 6 ft. OPTION 1	300 mm - 12 in.	400 x 400 mm - 16 x 16 in.	600 mm - 24 in.	6 x 6	2 x 6
OPTION 2	300 mm - 12 in.	400 x 400 mm - 16 x 16 in.	600 mm - 24 in.	6 x 6	2 x 6
L1 configuration = 2.4 m - 8 ft. and L2 = 1.2 m - 4 ft.					
0 to 3 ft. OPTION 1	600 mm - 24 in.	N/A	600 mm - 24 in.	4 x 4*	2 x 4
3 to 4 ft. OPTION 1	300 mm - 12 in.	400 x 400 mm - 16 x 16 in.	600 mm - 24 in.	4 x 4*	2 x 4
OPTION 2	300 mm - 12 in.	Ø 600 mm - 24 in.	600 mm - 24 in.	4 x 4*	2 x 4
4 to 6 ft. OPTION 1	300 mm - 12 in.	400 x 400 mm - 16 x 16 in.	600 mm - 24 in.	6 x 6**	2 x 6
OPTION 2	300 mm - 12 in.	Ø 600 mm - 24 in.	600 mm - 24 in.	6 x 6**	2 x 6

N/A: Not Applicable * 4 x 4 SFP wood select structural ** 6 x 6 #1 SFP wood

It should be noted that the base of concrete pillars should normally have a wider section in the ground for a footing. The footing can take two shapes, square or round. There are round footings on the market, sold as BIGFOOT, which can be used for the construction of pillars. Square footings must be made on site with wooden formwork.

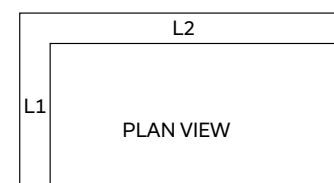

DESIGN ASSUMPTIONS

- The construction of privacy walls or fences must take into account the following assumptions:
- > Wall weight (grid and veneers): 28 lbs/ft² (1.35 kN/m²)
 - > Wind: 20 lbs/ft² (1 kPa)
 - > Minimum allowable bearing capacity of soil: 1575 lbs/ft² (75 kPa)
 - > Density of soil around pillars and foundations (γ): 18 kN/m³
 - > Backfill must be compacted around Sonotubes and spread footings

- > Minimum depth of foundations: 6 ft (1.8 m} away from frost (consult an engineer to check the typical depth of frost for your area) It may be necessary to consult an engineer.

Leave a free space under the Tandem wall of at least 75 mm - 3 in. to ensure proper ventilation and adequate room for the potential effects of freezing and thawing.

NOTE: Design assumptions do not take into account earthquake effects. It may be necessary to consult an engineer.

PRIVACY WALL AND FENCE - TYPICAL FRONT VIEW

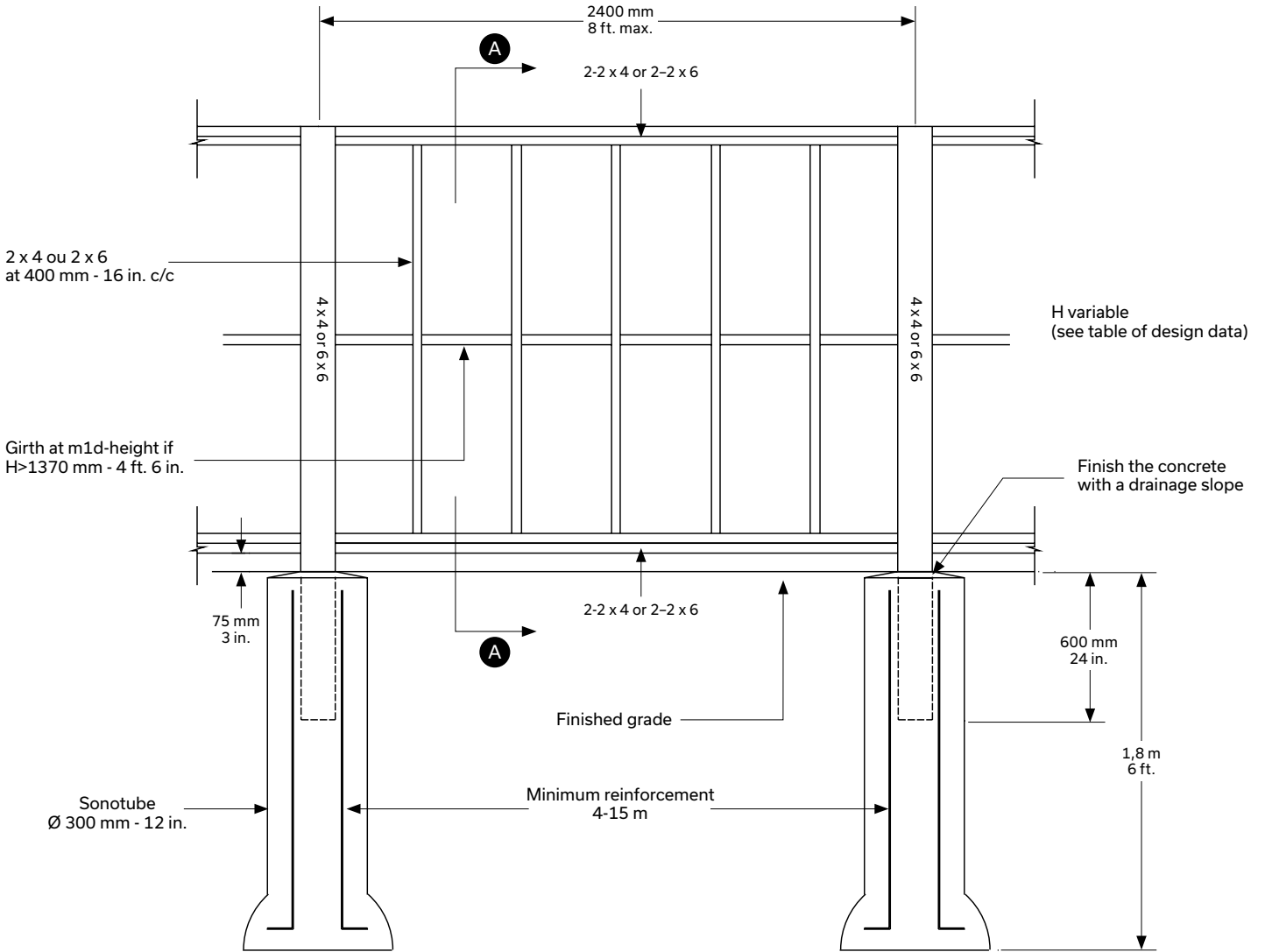

FOOTING
For different footing options, see the design data chart.

NOTE: The details shown here are only valid for the application suggested in this guide, taking into account the prescribed limitations. You are strongly recommended to engage a structural engineer or specialist in the field to validate structural design details for other configurations or for different soil conditions (lower or higher load capacity, presence of blocks, support on rock, etc.).

PRIVACY WALL AND FENCE - CROSS-SECTION A-A

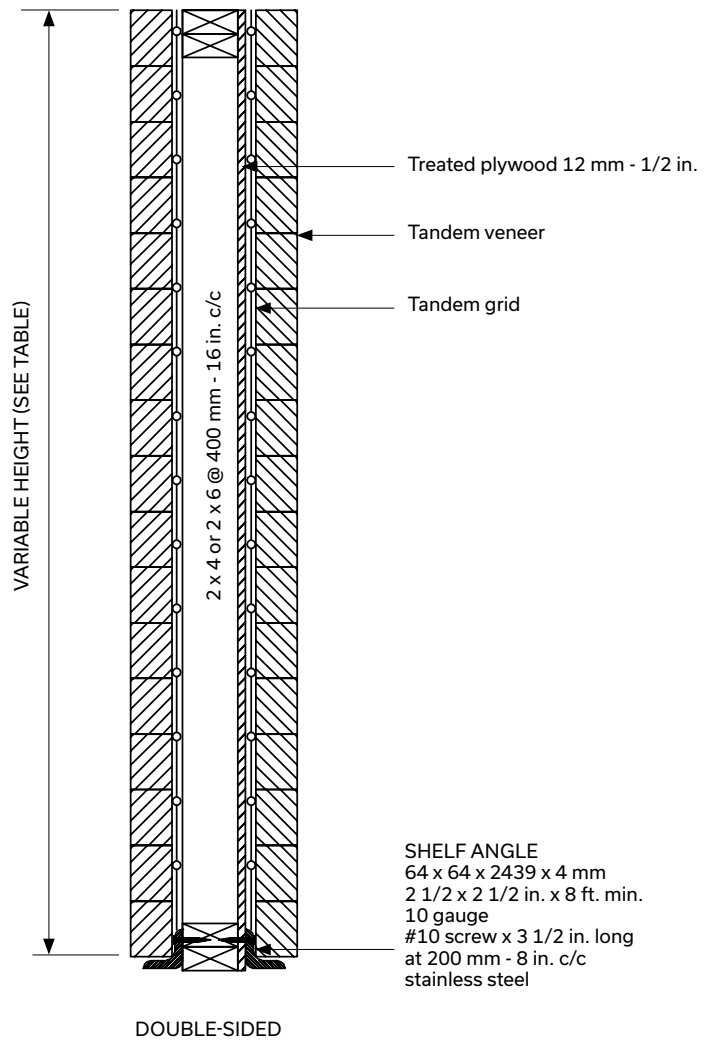
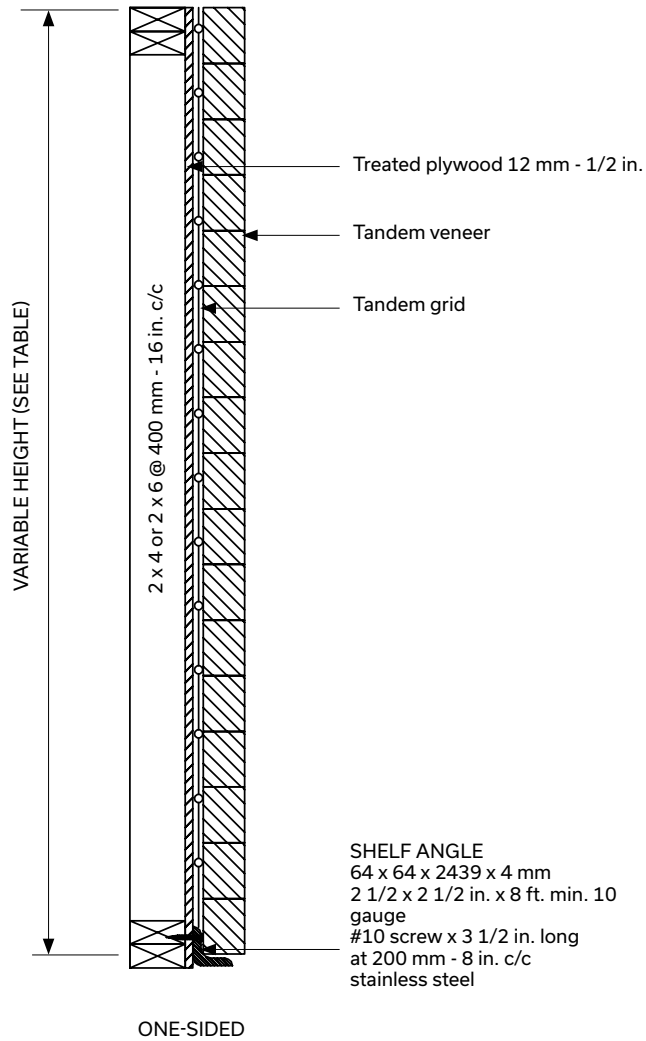

WOODEN STRUCTURE SCREW DIAGRAM OF COMPONENTS

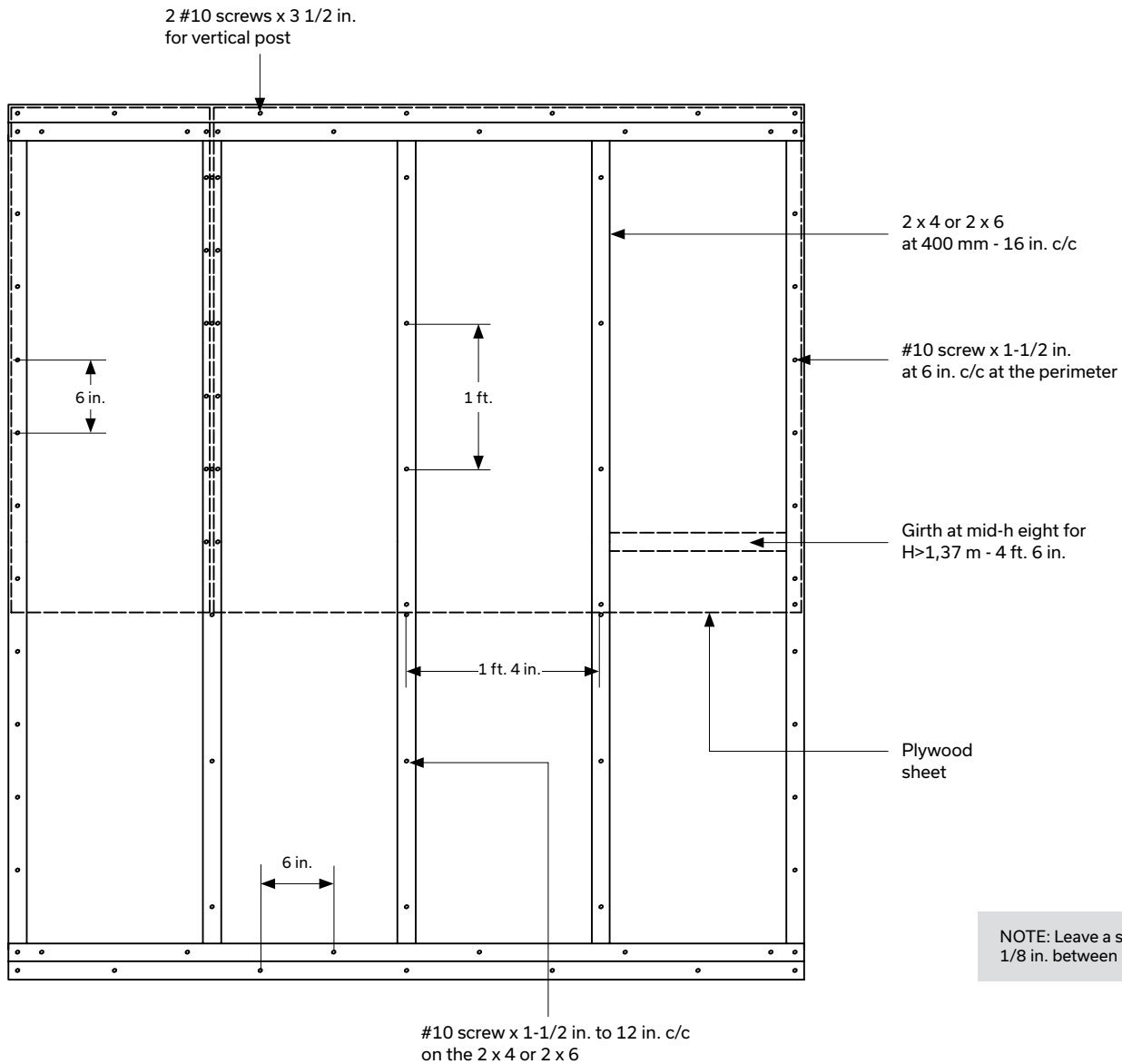

NOTE: Leave a space of 2-3 mm - 1/8 in. between plywood sheets

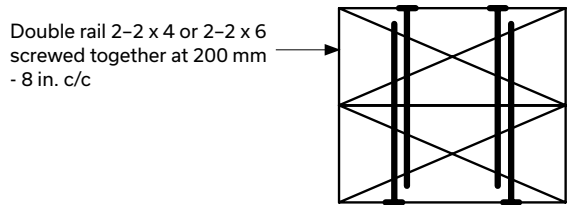

Assembly 2-2 x 4 or 2-2 x 6 #10 screw x 3 1/2 in. long staggered

BUILDING DECK SKIRTING

**APPLICATIONS:
NEW WOOD OR CONCRETE DECKS OR EXISTING CONCRETE DECKS**

Another application of the Tandem grid consists of covering the free space under a deck by building a Tandem wall around it. Tandem veneers are supported by a galvanized shelf angle and a wood frame fixed to the deck (wood or concrete). The wood frame consists of treated plywood to provide a continuous attachment area for the grid, and vertical bracing to stabilize the structure and withstand lateral loads such as the wind. The whole structure is supported by appropriate foundations (screw piles for wooden decks and concrete foundations for concrete decks).

MAXIMUM HEIGHT OF TANDEM WALL: 1.5 m - 5 fl.

To install deck skirting on existing concrete structures, you must first ensure that the initial structure (the deck itself) can bear the additional weight of new covering components, wooden structure, shelf angle and Tandem veneers.

For this kind of project, it is strongly recommended to engage a structural engineer or specialist in the field to validate the structural design details for adequate load bearing.

In all cases, it is necessary to minimally comply with the design criteria shown below:

- > Wall weight (grid and veneers): 1.35 KN/m² (28 lb/sq.ft.)
- > Wind: 1 kPa (21 lb/sq.ft.)
- > Overload: 1.9 kPa (40 lb/sq.ft.)

**MINIMUM ALLOWABLE BEARING CAPACITY OF SOIL:
75 KPA (1575 lbs/sq.ft.)**

NOTE: Design assumptions do not take into account earthquake effects. It may be necessary to consult an engineer.

Minimum depth of foundations in soil: 1.8 m - 6 ft. away from frost (consult an engineer to check the typical depth of frost for your area).

Leave a free space of at least 75 mm - 3 in. under the Tandem wall.

NOTE: As there is no direct access from the top of a unit (since the Tandem wall is built under the deck), it will be impossible to attach the last row of veneers to the Tandem grid with connectors. Simply glue the last row of veneers to the second-to-last row with Techniseal concrete adhesive.

The sketches shown here have been designed to withstand the additional loads of Tandem walls. The details shown are valid for applications suggested in this guide. It is strongly recommended to engage a structural engineer or specialist in the field to validate structural design details for other configurations.

NOTE: Please consult your Permacon sales representative for more information on how to create a curved wall.

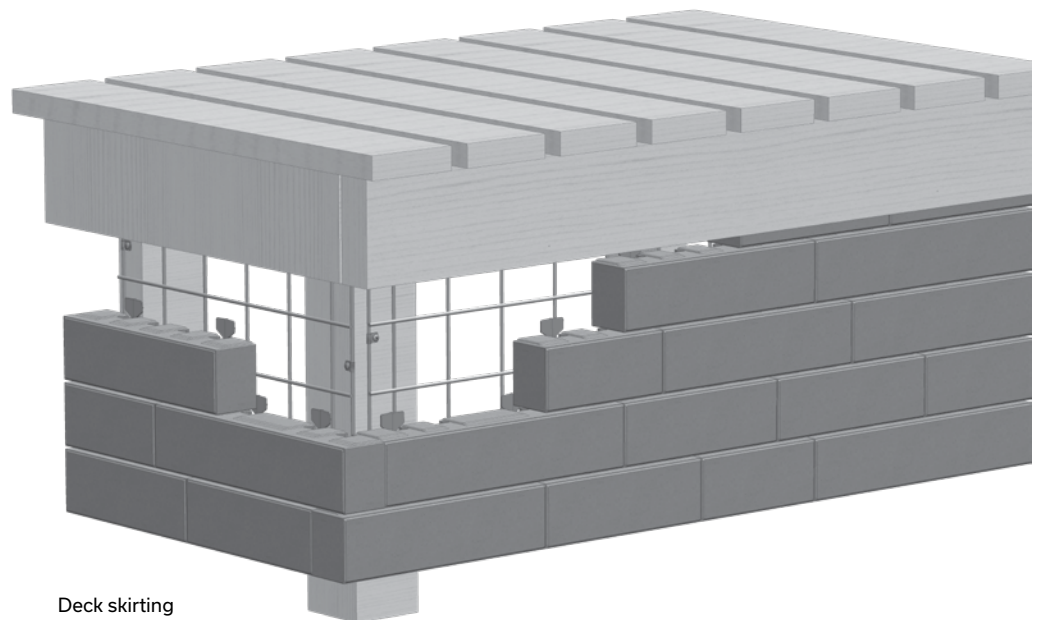

Deck skirting
ISOMETRIC VIEW

CONSTRUCTION OF OUTDOOR LIVING COMPONENTS WITH THE TANDEM MODULAR GRID

CONCRETE DECK

To cover a concrete deck, you must comply with additional minimum design criteria detailed below:

THE MINIMUM THICKNESS OF THE SLAB should be 140 mm - 5 1/2 in.

The slab should be reinforced with a minimum IOM reinforcement at 300 mm - 12 in. c / c in both directions and positioned at the center of the slab. The concrete deck should be supported by pillars of reinforced concrete (Sonotubes), 200 mm - 8 in. in diameter with a minimum footing of 600 mm - 24 in. or larger in diameter.

The compressive strength of the concrete (slab and pillars) must be at least 30 MPa with 5% to 8% entrained air.

MAXIMUM DISTANCE BETWEEN PILLARS: 2400 mm - 8 ft.

MAXIMUM OVERHANG OF CONCRETE SLAB: 600 mm - 2 ft.

To attach the components of the wooden structure to the concrete slab, you should use mechanical anchors like Hilti Kwik Bolt TZ (12 mm diameter by 140 mm long) or equivalent (not supplied by Permacon).

Leave a space of at least 12 mm - 1/2 in. between the top of the Tandem wall and the underside of the concrete slab.

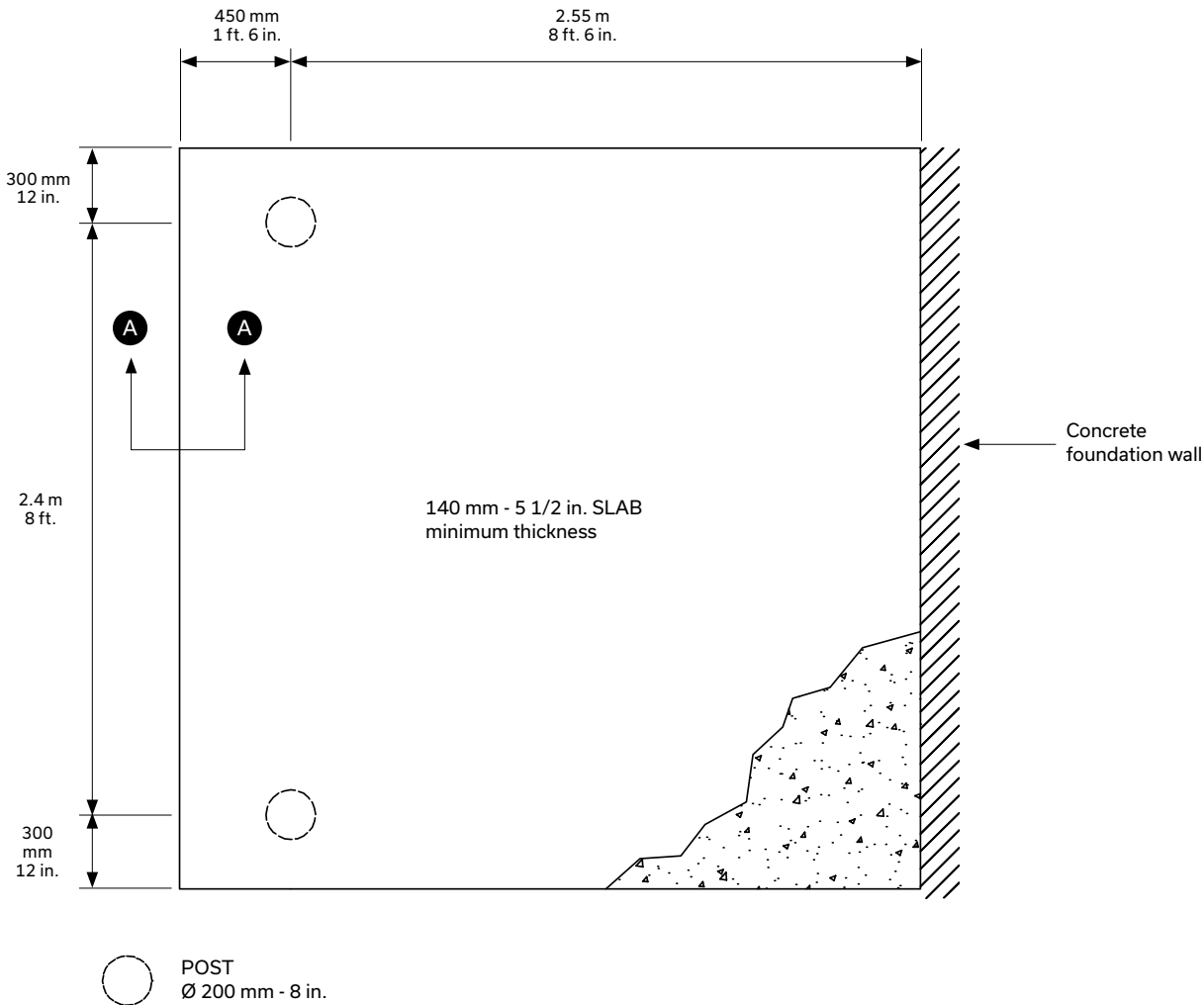

Concrete deck skirting
PLAN VIEW

CONCRETE DECK SKIRTING - CROSS-SECTION A-A

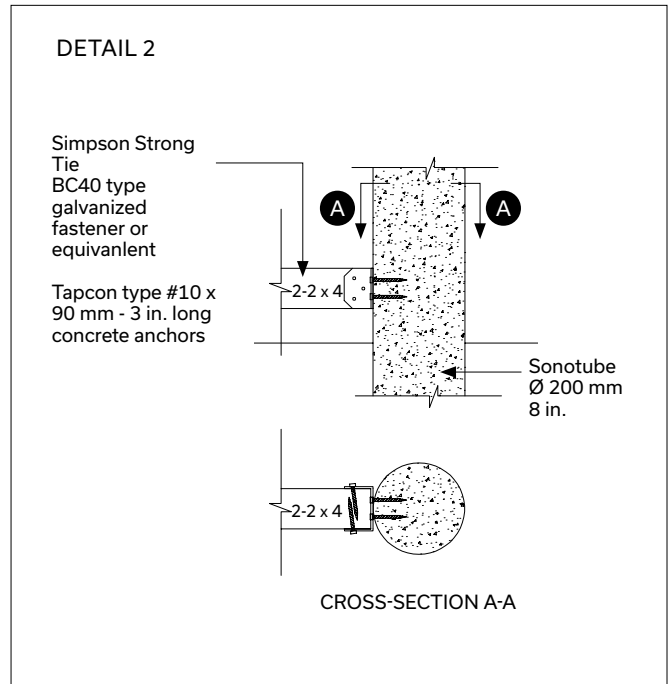
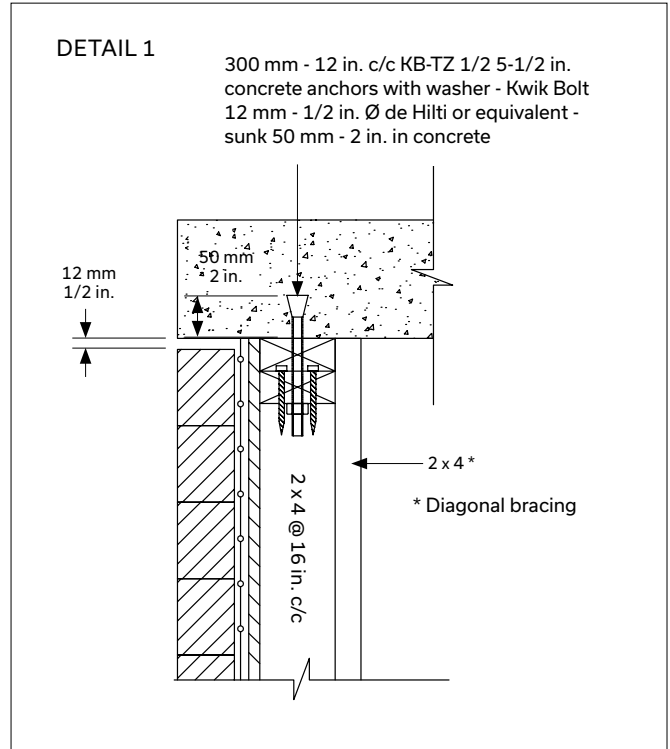
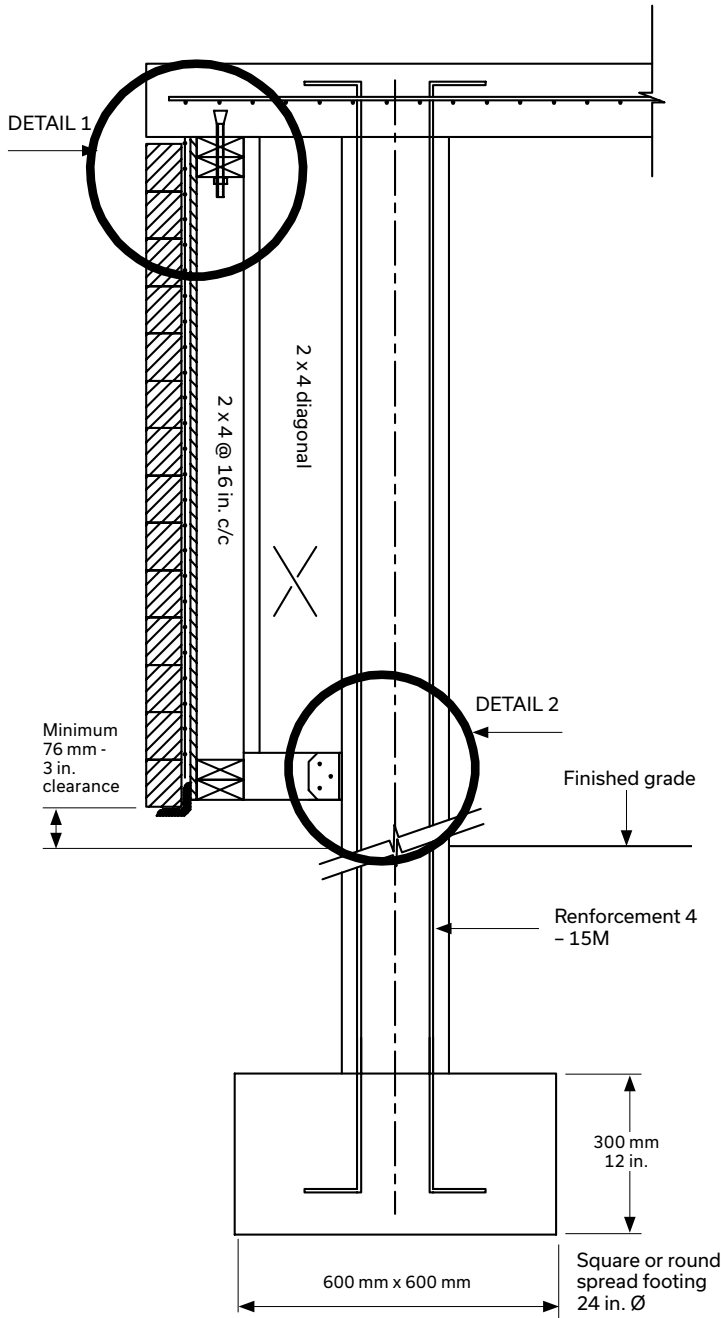

WOOD DECK

WARNING: We recommend installing a Tandem wall only for new wooden decks to be built according to the minimum specifications and data detailed below.

The wooden deck should be built with a structure composed of 2 x 8 joists spaced every 400 mm - 16 in. or less. The deck beams must be made of at least two 2 x 8 boards.

The beams are supported on 89 x 89 mm - 4 x 4 in. wooden posts. The posts themselves are supported on screw piles designed for this purpose (helical piles).

MAXIMUM LENGTH OF WOOD JOISTS IN BOTH DIRECTIONS: 2400 mm - 8 ft.

MINIMUM OVERHANG of 300 mm - 12 in. and MAXIMUM OVERHANG of 600 mm - 2 ft.

To attach the components of the wooden structure to the deck joists, you should use #10 stainless steel wood screws.

Simpson Strong-Tie hardware (or equivalent) should be used.

A waterproofing membrane must be installed on top of the wood frame to protect the wood from water saturation and rot (in the case of wood board flooring with free space). The membrane can be omitted for waterproof deck flooring such as fiberglass.

It is recommended to leave a space of 1/8 to 1/4 in. between the wooden boards of the deck for ventilation under the deck so as not to trap moisture.

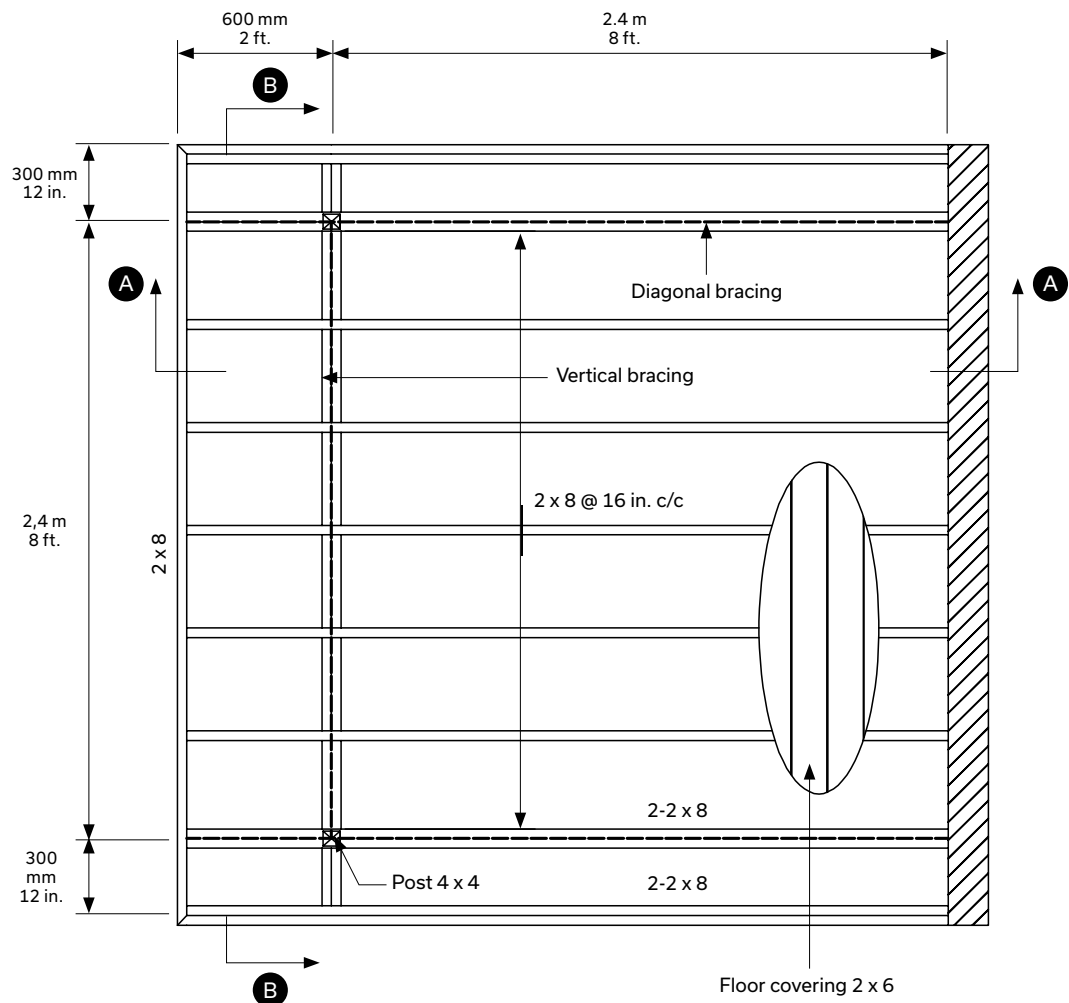

Floor structure - PLAN VIEW

CONSTRUCTION OF OUTDOOR LIVING COMPONENTS WITH THE TANDEM MODULAR GRID

WOODEN DECK SKIRTING - CROSS-SECTION A-A

- A Simpson Strong-Tie LUS 26 and LUS 26-2 (GA 18) galvanized steel joist hangers or equivalent
- B 2x8 continuous rail attached to foundation wall with Hilti KB-TZU 12 x 140 mm - 1/2 in. x 5 1/2 in. anchors or equivalent
Alternative: joists resting on foundation wall
- C Diagonal brace at mid-height for wall over 1200 mm - 4 in. tall
- D Floor coverings 2 x 6 spaced at 6 mm - 1/4 in.

NOTE: During construction, 2 x 4 posts should face floor joists to enable assembly construction.

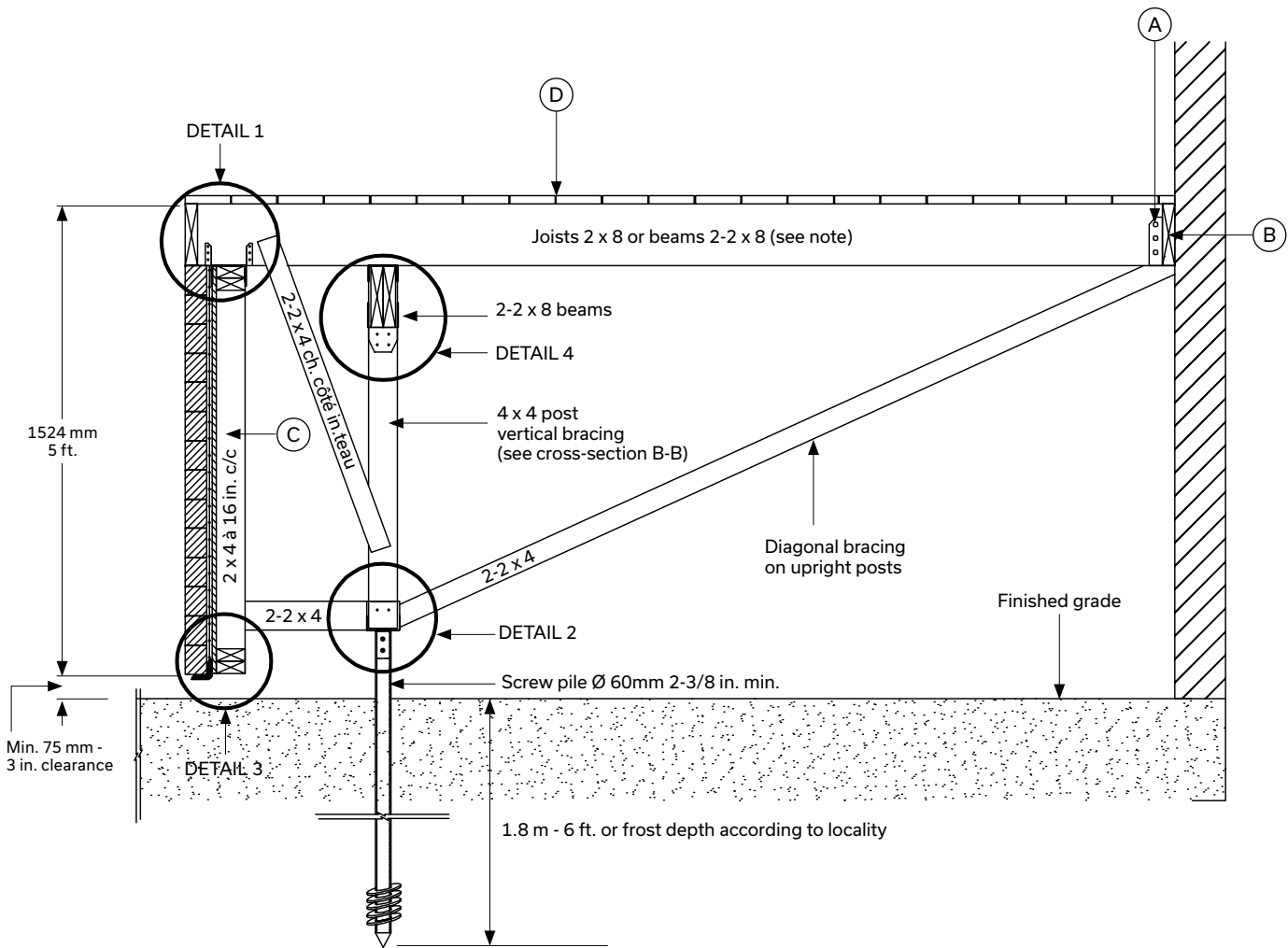

WOODEN DECK SKIRTING - CROSS-SECTION B-B

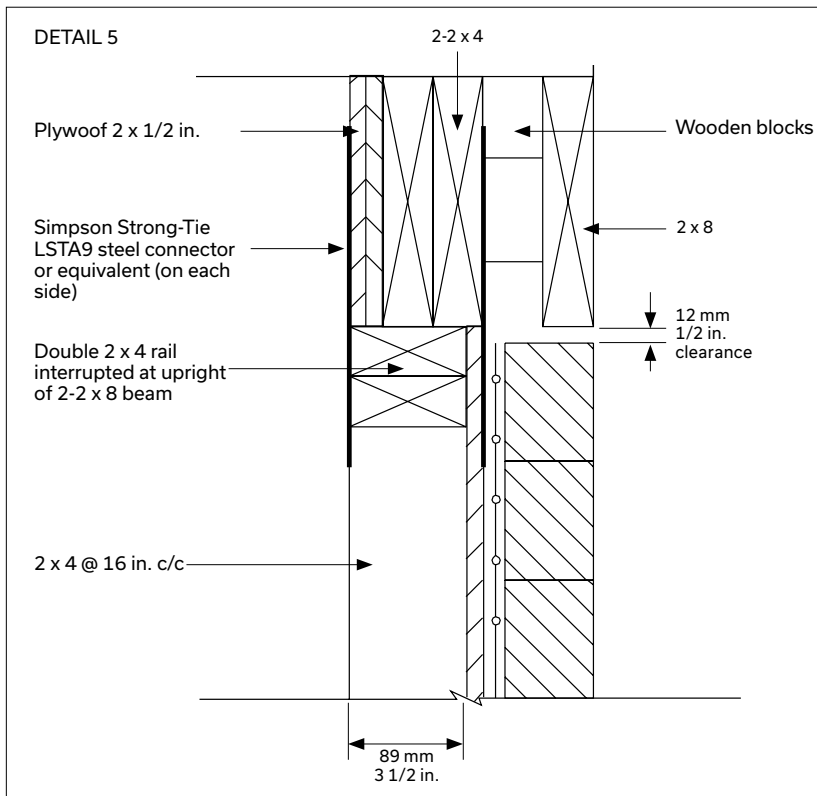
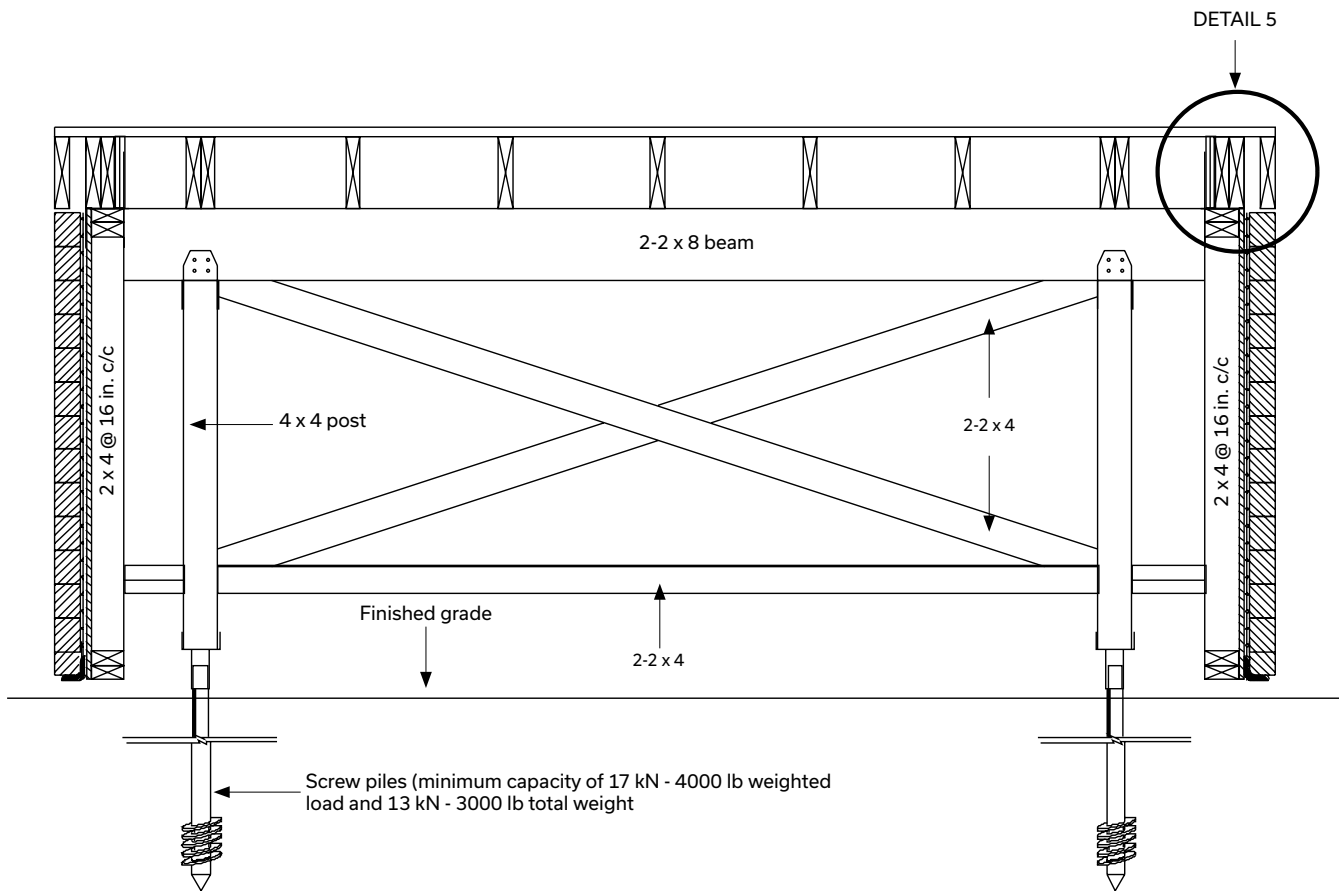

WOODEN DECK SKIRTING DETAILS - CROSS-SECTION A-A

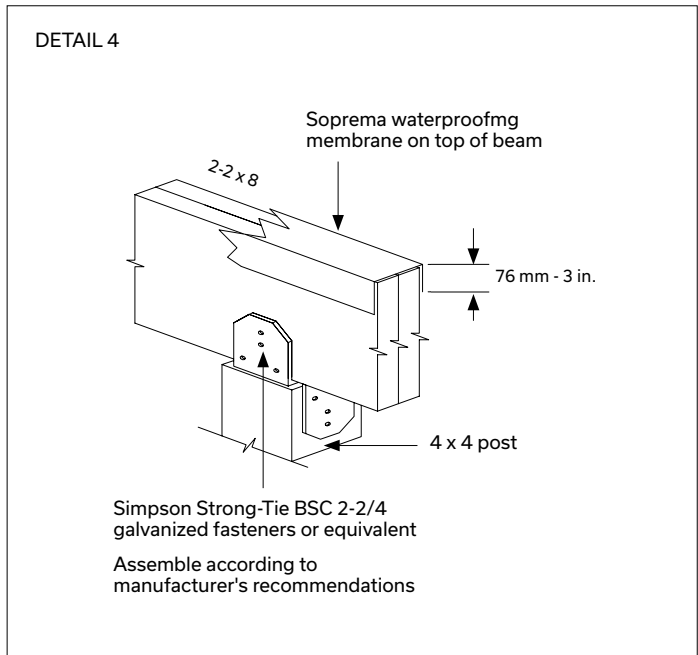
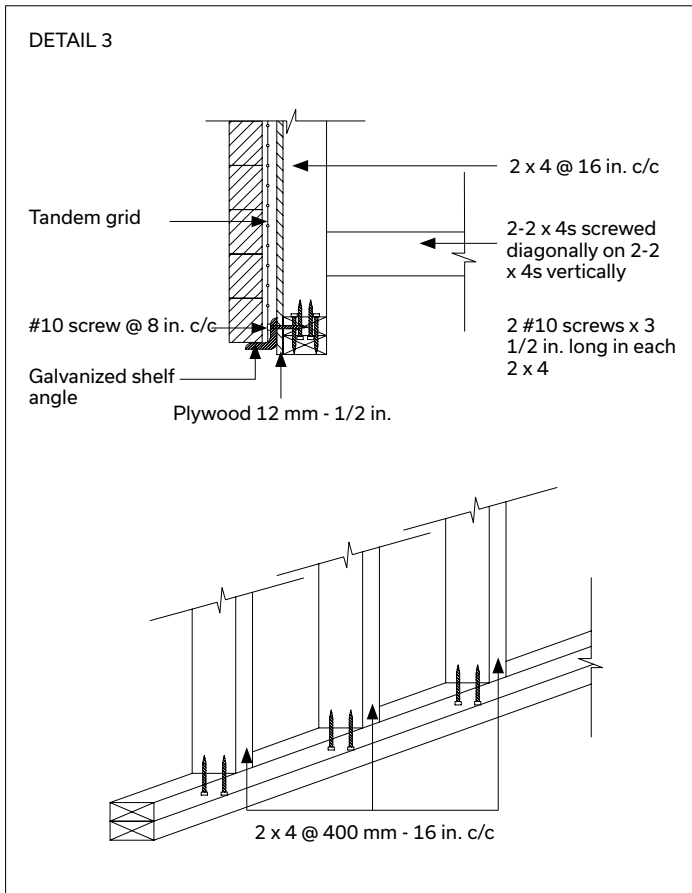
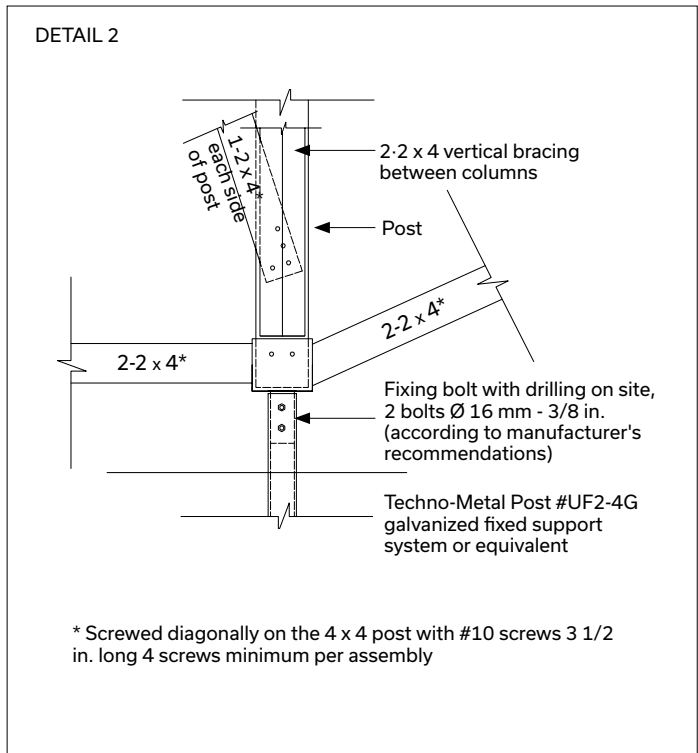
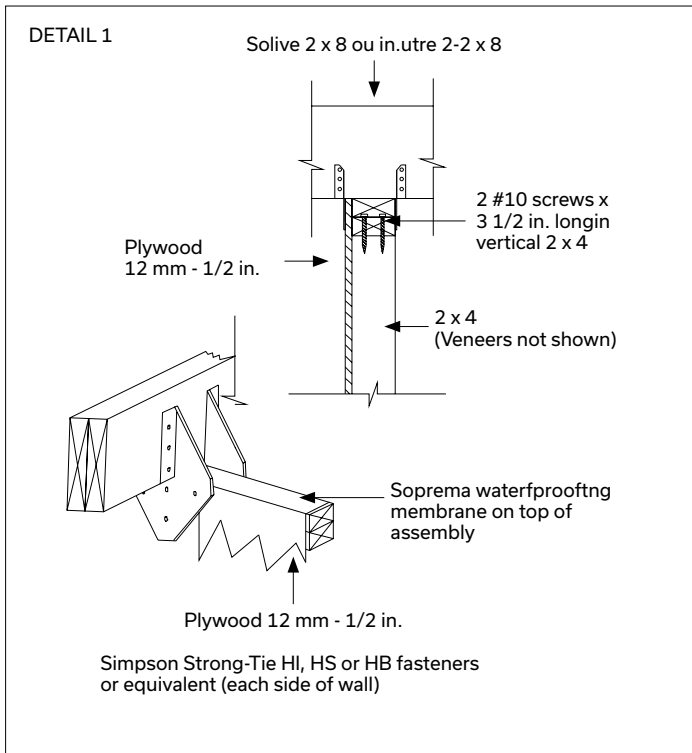

Celtik® Plus 90 Wall

DESCRIPTION



With a maximum height of 42 inches, the Celtik wall is reminiscent of old stone structures typical of the Irish and Scottish countryside. Its rich texture and variety of units gives you a choice between the uneven look of cut stone and the more linear look of a brick.

ADVANTAGES:

Patented anchor pin system located at the back of the block makes it possible to:

- > build sloped or vertical walls with minimum cutting, chiselling or using a guillotine
- > easily create a radius or curves

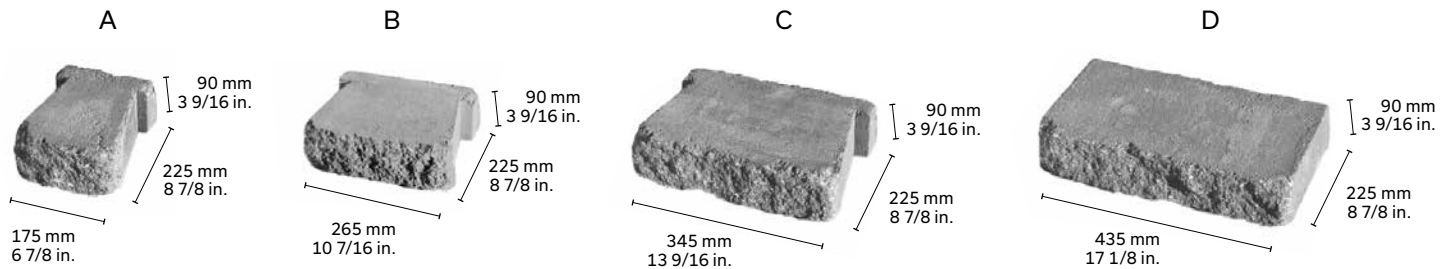

LAYING PATTERN

LINEAR PATTERN

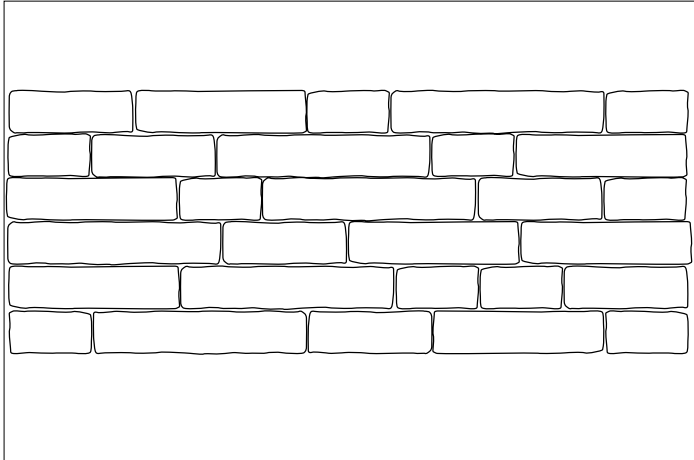

ANCHOR PIN SYSTEM

The Celtik wall anchor pin system is designed to facilitate the construction of walls with a maximum height of 42 in - 1.1 m. The special pin system is designed to stabilize the overall structure and guide the installation of units. The dual-position system allows for the construction of vertical or 9° sloped walls. Units are delivered with two different anchor pins: a regular pin with blades (C1) and a second pin without blades (C2), designed for the construction of corners.

For a 9° of slope, the setback per row of 90 mm is 14 mm - 9/16 in.

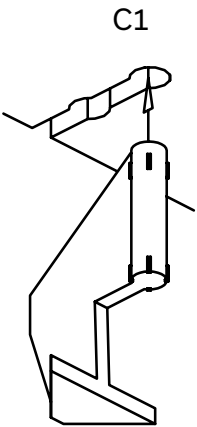

Position for building a wall on a 9° slope.
Maximum height of 1.05 m - 42 in.

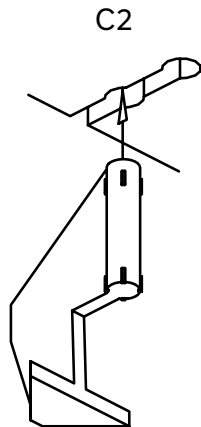

Position for building a vertical wall.
Maximum height of 0.65 m - 26 in.

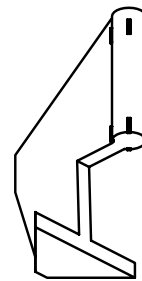

C1 - Base model

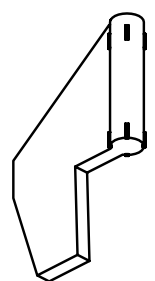

C2 - Model without blades

LAYING IDEAS

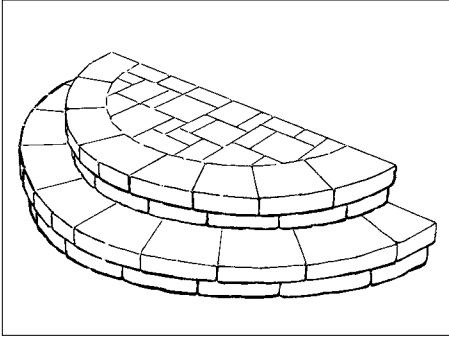

CURVED STEPS using 90 mm

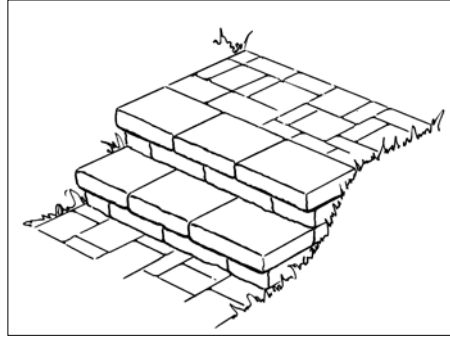

STRAIGHT STEPS

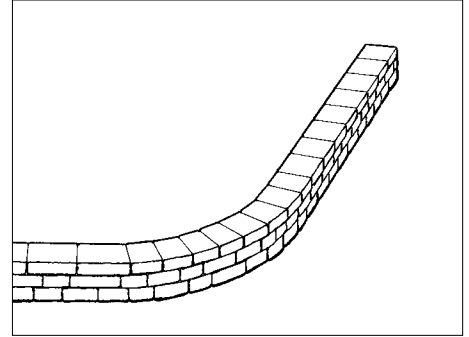

CURVED AND STRAIGHT WALL

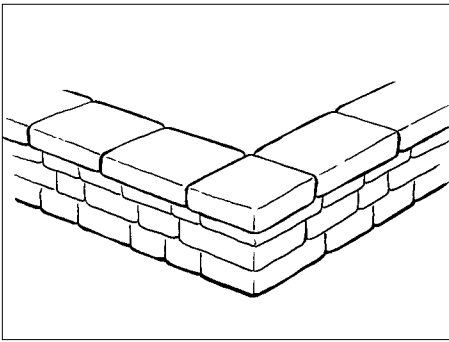

CORNER WITH STRAIGHT CUT

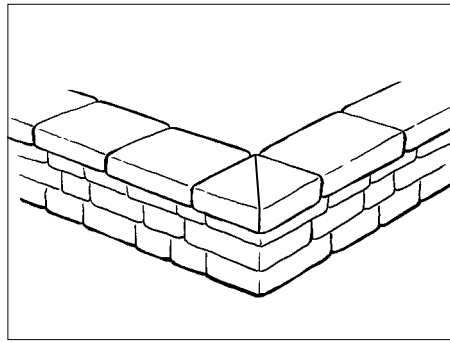

CORNER WITH 45° ANGLE CUT

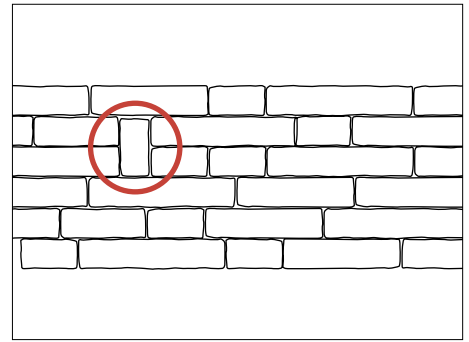

90 mm UNIT WITH JUMPER (vertical element)

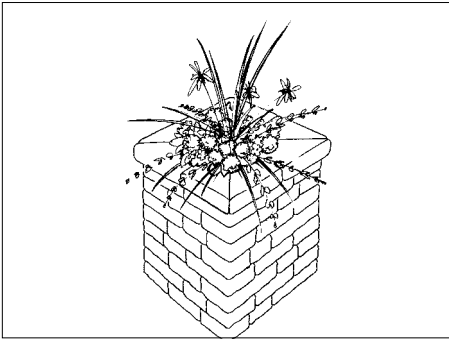

PILLAR with flowers

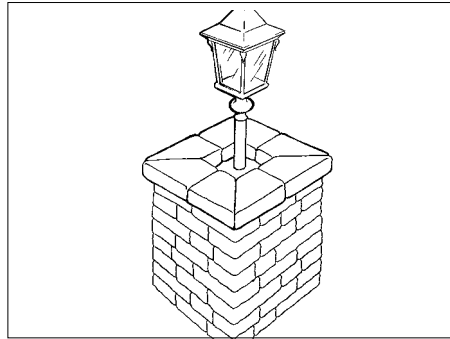

LIGHT PILLAR

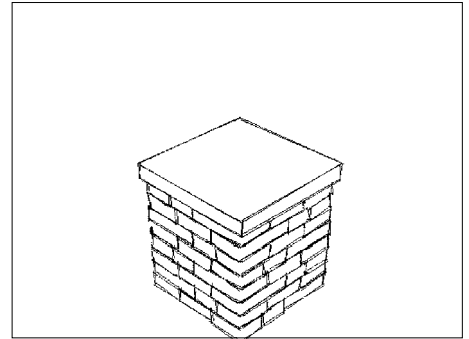

CELTIK 90 PILLAR

CELTIK PLUS WALL CONSTRUCTION

STEP 1

INSTALLATION OF THE FIRST ROW

Lay the units of the same thickness on the compacted foundation. It is important to carefully align the first row of units horizontally to ensure that the wall will be levelled. At this stage, no pins are used.

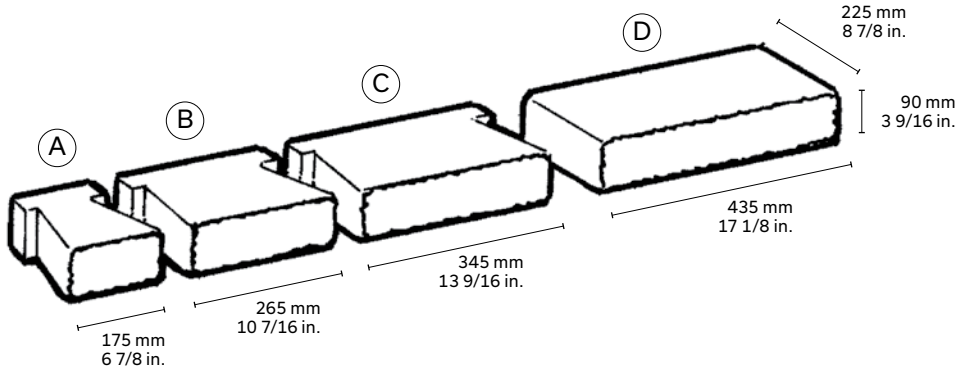

STEP 2

INSTALLATION OF THE FOLLOWING ROWS

Carefully lay the units of the following rows, remembering however, to insert a pin in each unit before installation. First insert pins in units to be installed. Use appropriate grooves depending on whether the wall is vertical (maximum 26 in.) or 9' sloped (maximum 42 in.). Lay each row by overlapping joints of the last row installed.

Supplied radiuses may be used vertically to give a natural and original look to the layout. Two of the radiuses measures two rows high. Use unit A (6 7/8 in.) to match two 90 mm rows.

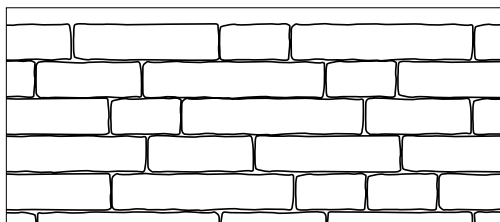

90 mm UNITS

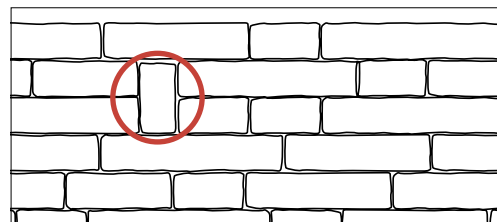

90 mm UNITS WITH JUMPERS (vertical elements)

STEP 3

BACK FILLING

Every two rows, fill the space behind units only with 3/4 in. - 20 mm clean stone. Repeat steps 2 and 3 up to the desired height.

NOTE: The dimensions of the Imperial system are approximate

CELTIK PLUS WALL CAPPING

OPTION A - REGULAR UNITS

Walls can also be capped using Celtik standard units, in one of two styles:

- > flush
- > overhanging

In either case, the units must be properly secured with adhesive to ensure wall stability. Save straight unit (D) for capping the straight portions of the wall. Use bevelled units for the curved portions; less cutting will be required.

ADVANTAGE

A Celtik retaining wall with standard units as capping units is economical, easy to install and versatile, offering a number of possibilities.

NOTE: Several small units will give a shorter bend radius, while larger units will give a larger radius.

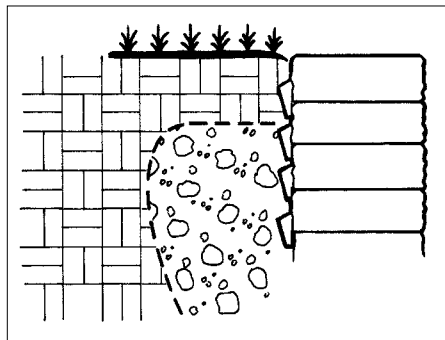
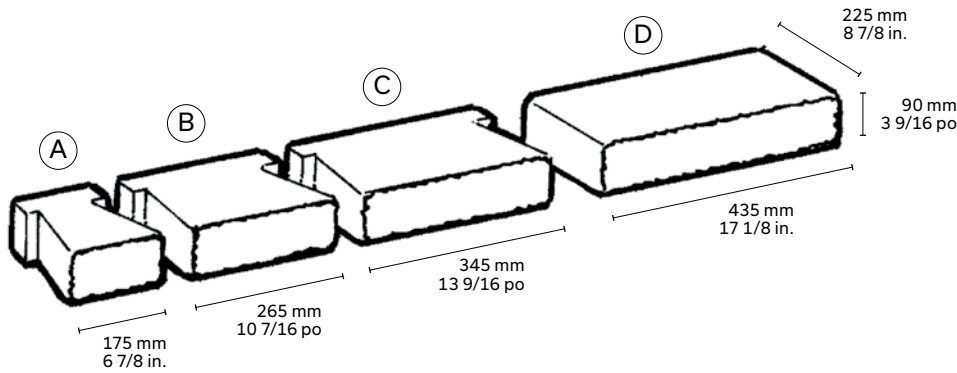

FLUSH CAPPING

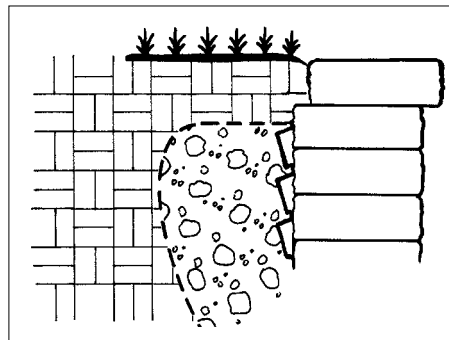

OVERHANGING CAPPING

BEFORE

AFTER

TO CREATE CURVES IN A CELTIK WALL: the minimum radius is 0.9 m - 3 ft.

CONVEX CURVE: strike the extremities of the unit at the back

CONCAVE CURVE: unit will have to be cut

OPTION B - CELTIK PLUS CAPPING UNITS

Use Celtik capping units to complete your wall. It is important to anchor the Celtik caps with Techniseal concrete adhesive.

NOTE: The dimensions of the Imperial system are approximate

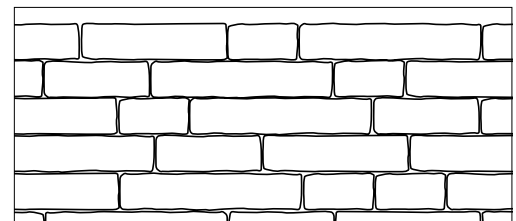

90 mm UNITS

CELTIK PLUS PILLAR USING ALL CELTIK PLUS UNITS

CELTIK PILLAR: 734 x 734 mm - 29 x 29 in.

To build a pillar minimizing joint alignment and better stability, be sure to follow the laying order for each step and row, as illustrated. Measure the site for the pillar(s). Each pillar measures of 734 x 734 mm - 29 x 29 in. Always secure each row with adhesive to ensure stability.

FOR THE CORNERS, CUT C AND D UNIT AS ILLUSTRATED:

- > Trim the C unit in the middle
- > Trim the D unit along one of the two grooves (left or right)

1 INSTALLATION OF THE FIRST ROW

Lay the first four units as illustrated (A, B, C and D) followed by the next four.

2 INSTALLATION OF THE SECOND, THIRD AND FOURTH ROWS

For each row, proceed as illustrated. Starting from the fifth row, repeat instruction steps 1 and 2, followed by the next ones until the desired height is reached (see illustration).

3 CAPPING A PILLAR

Use Celtik Plus straight capping units or a natural stone capping unit

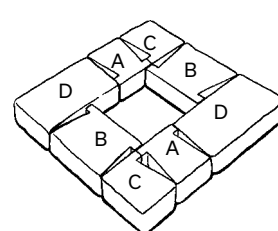
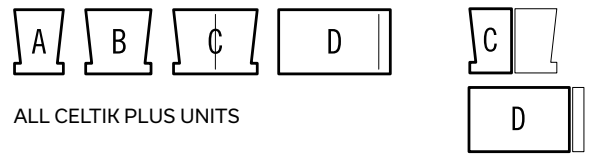

STEP 1 : rows 1 and 5

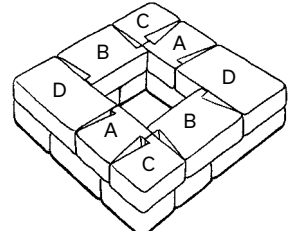

STEP 2 : rows 2 and 6

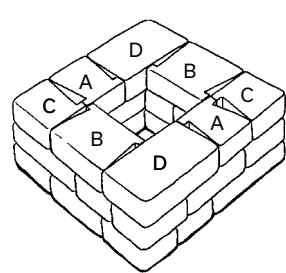

STEP 3 : rows 3 and 7

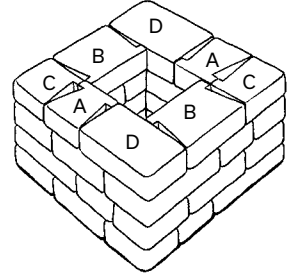

STEP 4 : rows 4 and 8

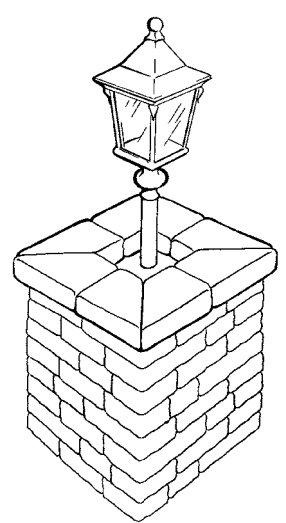
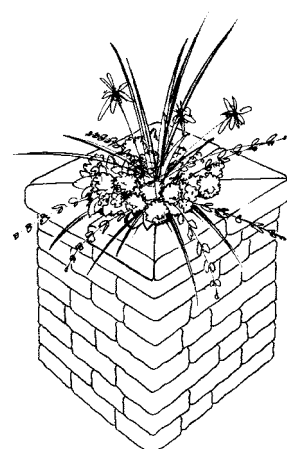
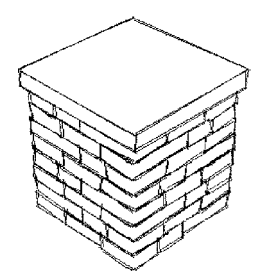
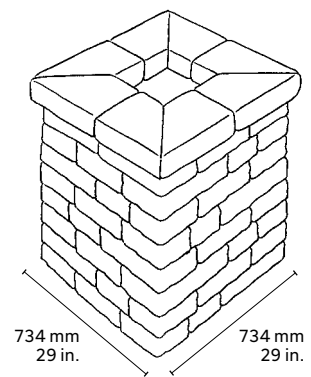

WARNING

If a lit pillar is desired, make sure all electrical wiring is completed before the units are laid.

If flowers are to be planted above the pillar, install a geotextile membrane inside the pillar before filling with garden soil.

CELTIK PLUS STRAIGHT CAPPING UNIT

The Celtik Plus straight capping unit can be used for all applications.

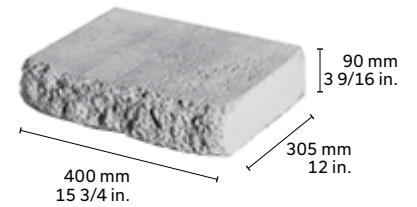

LAYING IDEA

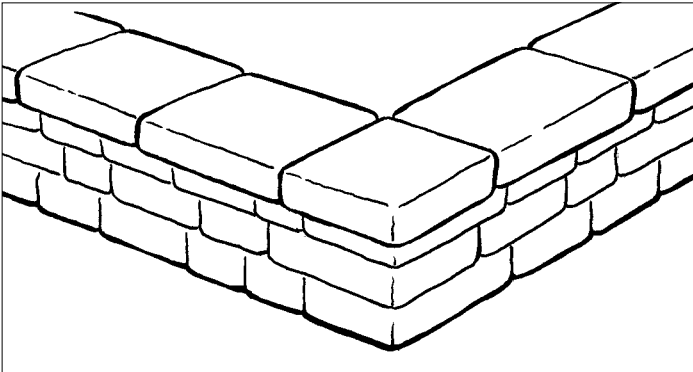

HOW TO ORDER

Celtik straight capping units are purchased individually. Each unit is 400 mm - 15 3/4 in. length.

- > Calculate the length in linear feet that you require for capping your Celtik wall
- > Divide the number of linear feet by 1.333 (the result will give you the number of units you need to cap your wall)
- > Order the required number of units

CAPPING A CORNER

PREPARE A CELTIK PLUS STRAIGHT CAPPING UNIT AS FOLLOWS:

- 1** Using a cold chisel or a guillotine, cut 100 mm - 4 in. from one of the ends of the capping unit
- 2** Flip the unit over and cut off the retaining lip
- 3** Hit the newly cut face with a sledge hammer to achieve the same finish as for the other sides
- 4** Install this corner cap first before proceeding with the installation of the other capping units
- 5** Always spread a layer of concrete adhesive along the top row of Celtik wall before laing the capping units

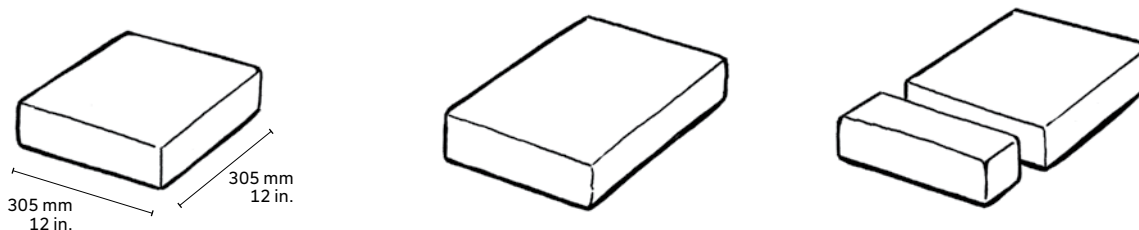

Grande® Wall

DESCRIPTION



The durable Grande® retaining wall comes in two architectural finishes: split face or smooth face.

The units that make up the Grande® wall are based on a unique tongue and groove interlocking technology. This provides greater flexibility, allowing you to build walls of virtually any height, with vertical setback or slope, relying on gravity or reinforced geogrid solutions.

BENEFITS:

- > Finish options: split or smooth
- > Quick and easy mechanical installation
- > Curved applications using Grande Wedge units
- > Ideal for large-scale retaining walls
- > Gravity or reinforced with geogrid installation, according to each project needs
- > No hardware required, thanks to its tongue and groove system
- > Several Grande Wall units suitable for different projects: standard wall unit, corner unit, step, capping and more



Since the design of a Grande Wall varies from one project to another, depending on the specifications of each, Permacon is able to provide a custom cross-section. For more information, please contact your Permacon representative or send an inquiry directly to our website.

The information contained in these technical documents is supplied for information purposes only. Any application of the information is the sole responsibility of the installer. The installer must ensure that the installation and use of retaining wall projects comply with local regulations and code requirements. A qualified engineer must be consulted for final design for construction purposes. Oldcastle Building Products Canada, Inc. and its affiliates cannot be held responsible for the improper use of information contained in these technical documents. Mettre la photo lifestyle plus petite au besoin.

GRANDE WALL - INSTALLATION

GRANDE WALL STANDARD UNITS

ISOMETRIC VIEW

375 STANDARD

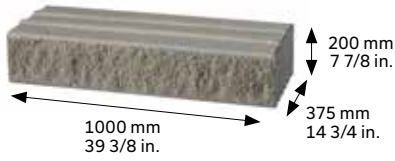

750 STANDARD

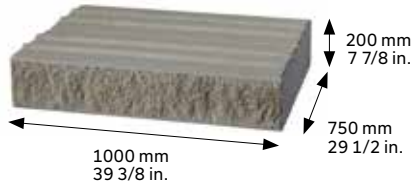

1125 STANDARD



TYPICAL ROW - TOP VIEW



ISOMETRIC VIEW

CORNER UNIT

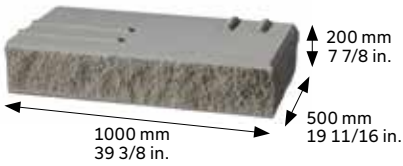

STEP 175

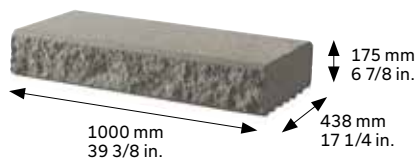

CAPPING 438

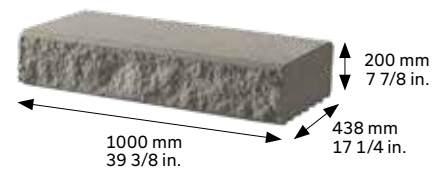

TYPICAL ROW - TOP VIEW

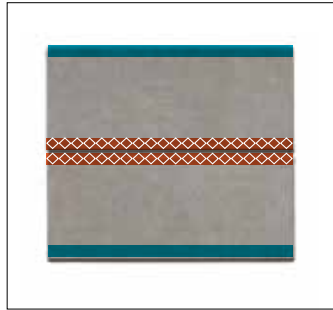
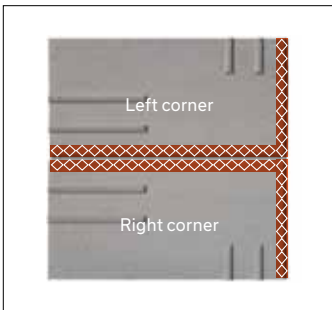

LEGENDE Smooth face  Split face 

GRANDE SMOOTH WALL STANDARD UNITS

375 STANDARD

ISOMETRIC VIEW

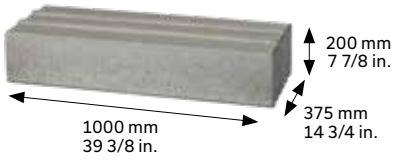

750 STANDARD



1125 STANDARD

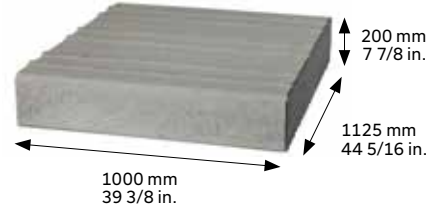

TYPICAL ROW - TOP VIEW



CORNER UNIT

ISOMETRIC VIEW

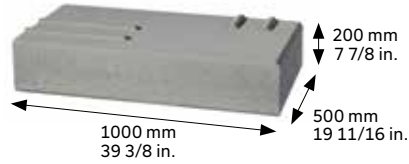

STEP 175

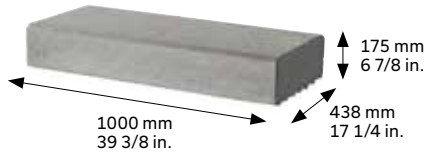

CAPPING 438

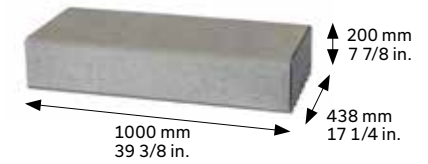

TYPICAL ROW - TOP VIEW

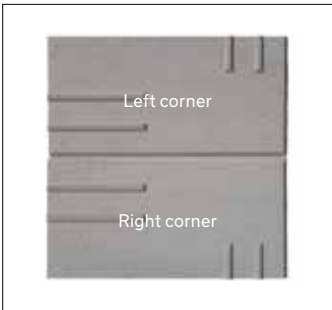

GRANDE WALL - INSTALLATION

GRANDE WALL WEDGE UNITS

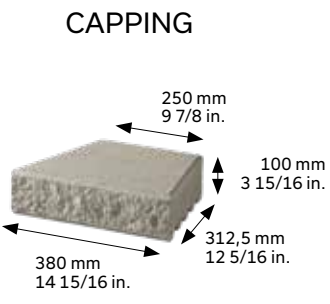
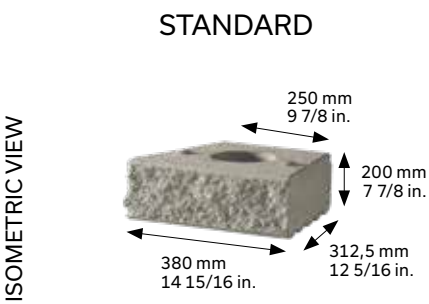

Please note that Grande Wedge Wall is available in split face finish only, with one split face, and one smooth face on each unit.

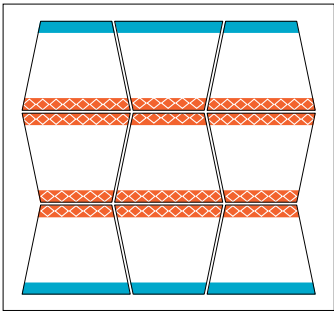
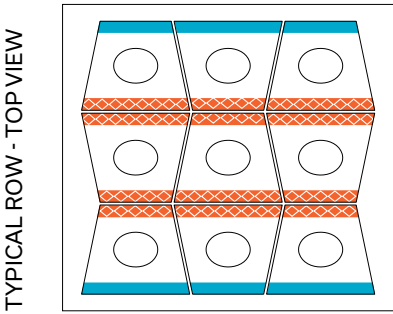

LEGENDE Smooth face  Split face 

BASIC PRINCIPLES

Grande 375 Standard Unit



Grande Corner Unit (right)

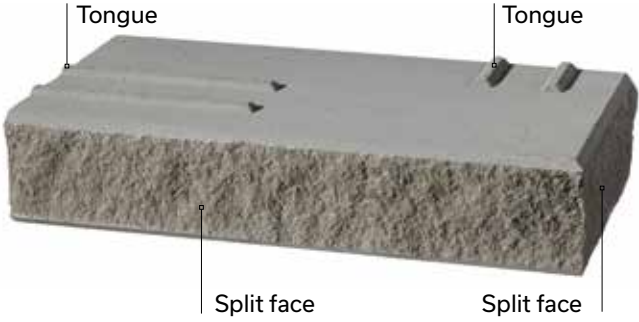

Grande Smooth 375 Standard Unit

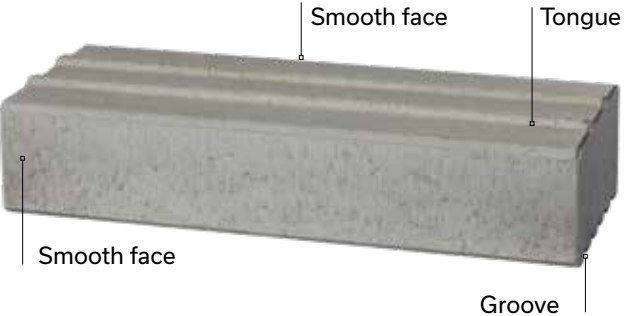

Grande Smooth Corner Unit (right)

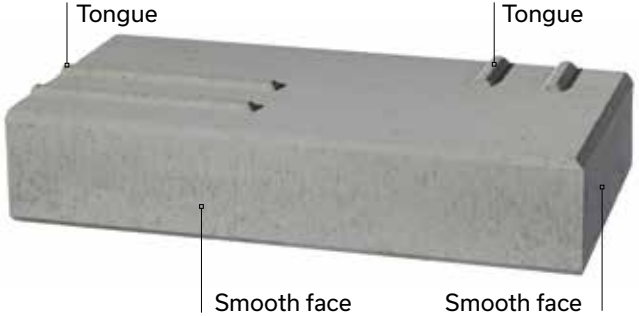

GRANDE WALL - INSTALLATION

LAYING PATTERN

RUNNING BOND PATTERN

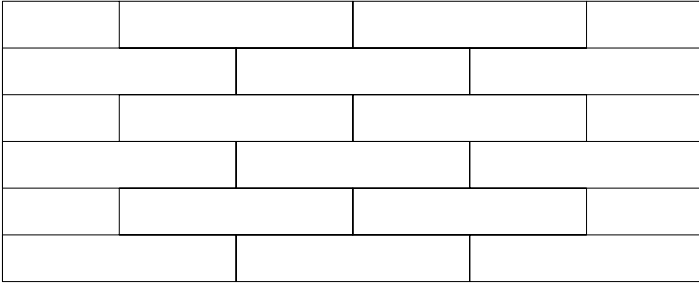

CREATING OUTER AND INNER CORNERS

It is recommended to always begin the construction of a retaining wall with a corner in order to avoid cuts and an alignment of vertical joints from one row to another.



ISOMETRIC VIEW - OUTER CORNER



ISOMETRIC VIEW - INNER CORNER

GRANDE WALL - INSTALLATION

OUTER 90° CORNER

To create a 90° outer corner, follow these instructions:

- 1 - Begin the construction of a retaining wall with a corner in order to avoid cuts and an alignment of vertical joints from one row to another
- 2 - Alternate each row
- 3 - It is possible to start with a right corner or a left corner, as desired
- 4 - Use Techniseal concrete adhesive between each corner unit to ensure increased stability
- 5 - Units requiring cutting should be cut at least 125 mm - 5 in.
- 6 - Part of the corner units tongues should be chiseled off to allow interlocking with the upper rows

Plan view - Odd rows

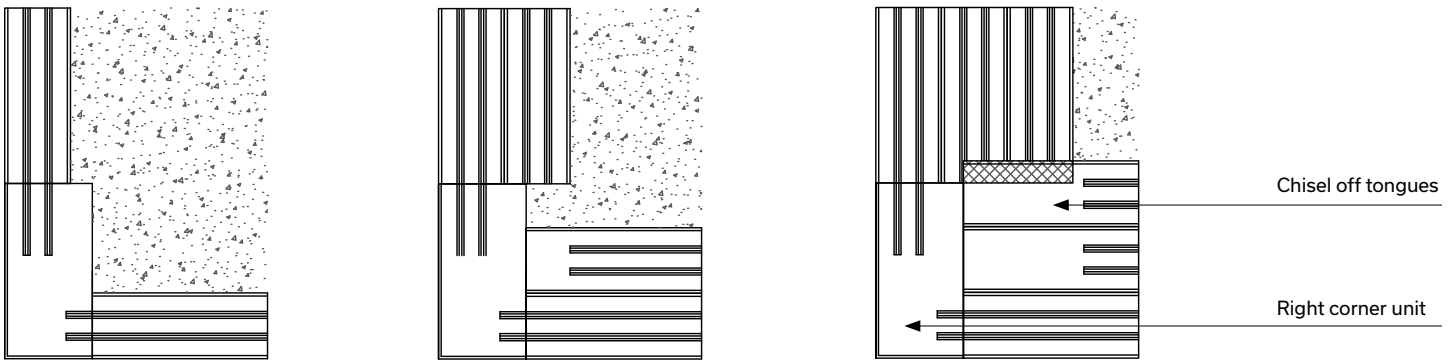

Plan view - Even rows

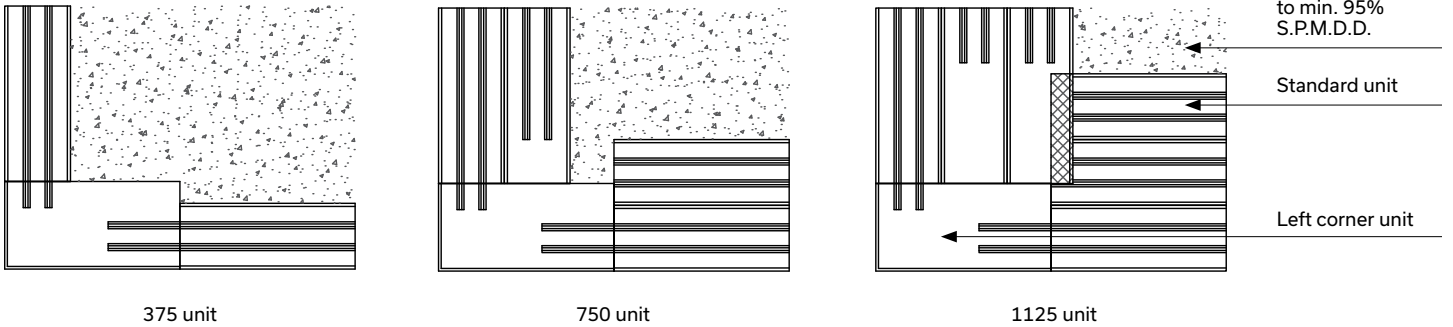

INNER 90° CORNER

To create a 90° inner corner, follow these instructions:

- 1 - Begin the construction of a retaining wall with a corner in order to avoid cuts and an alignment of vertical joints from one row to another
- 2 - Alternate each row
- 3 - It is possible to start with a right corner or a left corner, as desired
- 4 - Use Techniseal concrete adhesive between each corner unit to ensure increased stability
- 5 - Part of the corner units tongues should be chiseled off to allow interlocking with the upper rows

Plan view - Odd rows

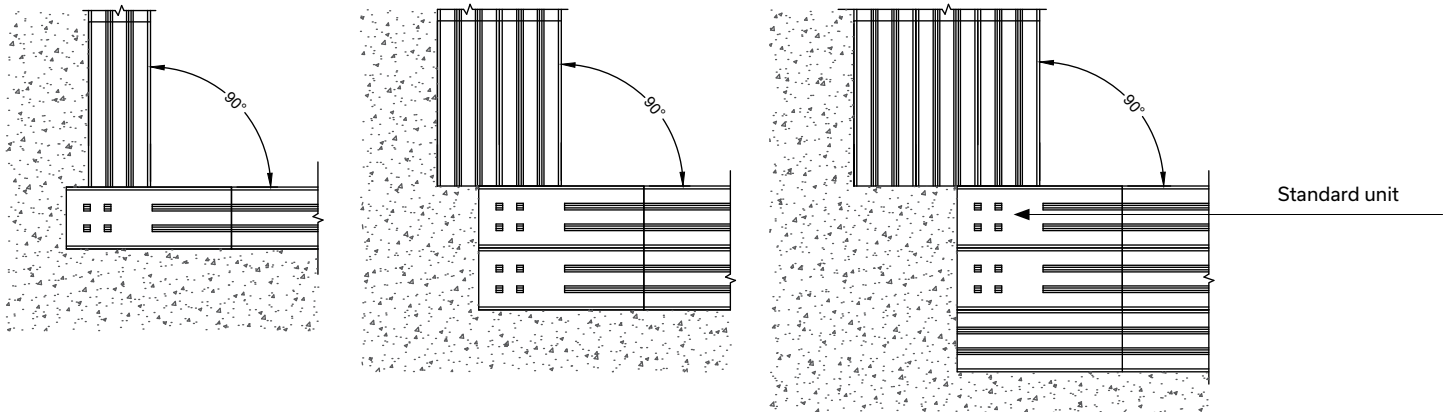

Plan view - Even rows

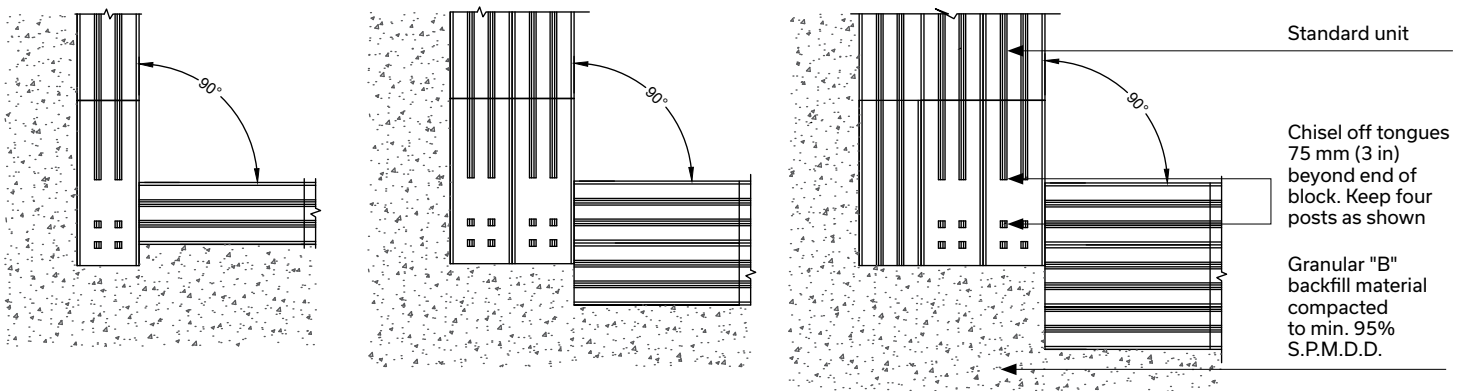

375 unit

750 unit

1125 unit

GRANDE WALL - INSTALLATION

OUTER ANGLE CORNER

To create an outer angle corner, follow these instructions:

- 1 - Begin the construction of a retaining wall with a corner in order to avoid cuts and an alignment of vertical joints from one row to another
- 2 - Alternate each row
- 3 - It is possible to start with a right corner or a left corner, as desired
- 4 - Use Techniseal concrete adhesive between each corner unit to ensure increased stability
- 5 - Part of the corner units tongues should be chiseled off to allow interlocking with the upper rows

Plan view - Odd rows

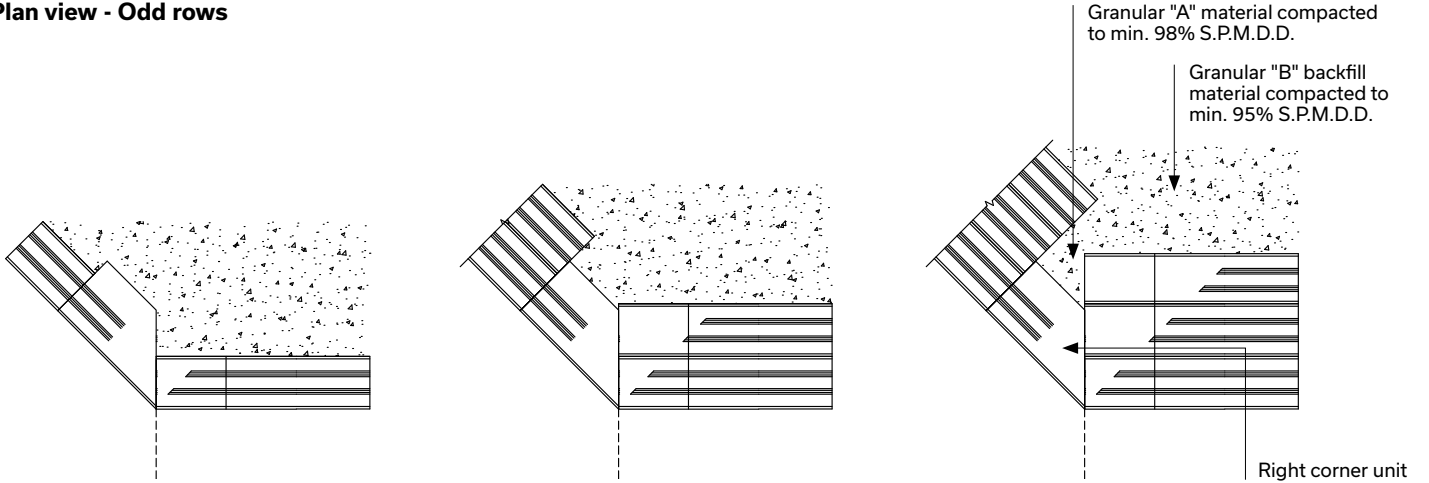

Plan view - Even rows

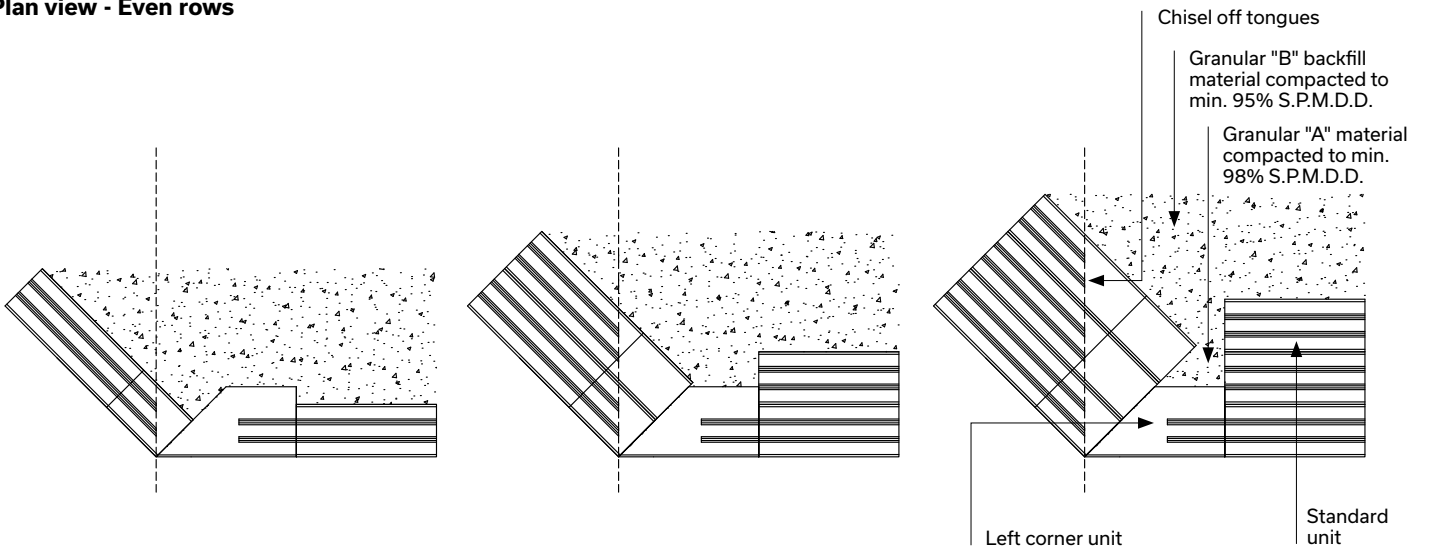

375 unit

750 unit

1125 unit

GRANDE WALL - INSTALLATION

INNER ANGLE CORNER

To create an inner angle corner, follow these instructions:

- 1 - Begin the construction of a retaining wall with a corner in order to avoid cuts and an alignment of vertical joints from one row to another
- 2 - Alternate each row
- 3 - It is possible to start with a right corner or a left corner, as desired
- 4 - Use Techniseal concrete adhesive between each corner unit to ensure increased stability
- 5 - Units requiring cutting should be cut in a way to have a unit of at least 500 mm - 20 in. in length

Plan view - Odd rows

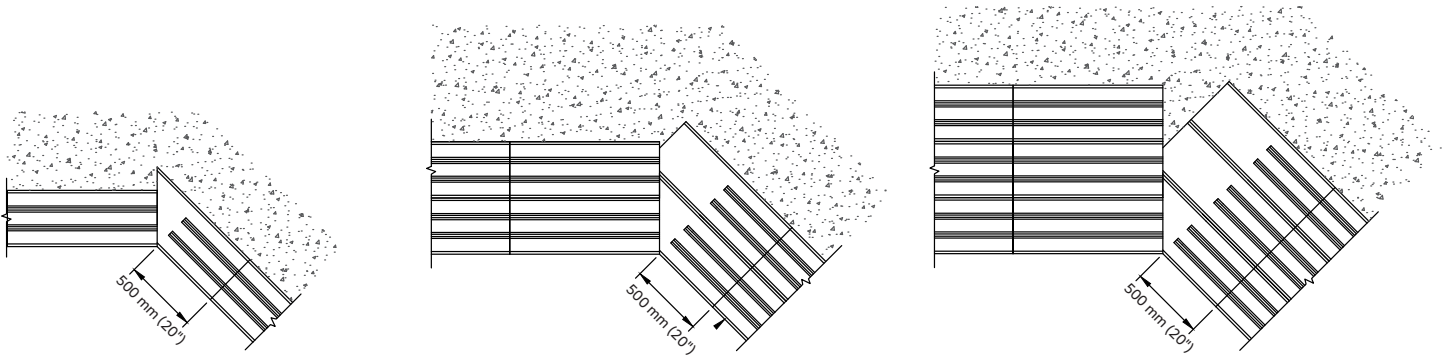

Plan view - Even rows

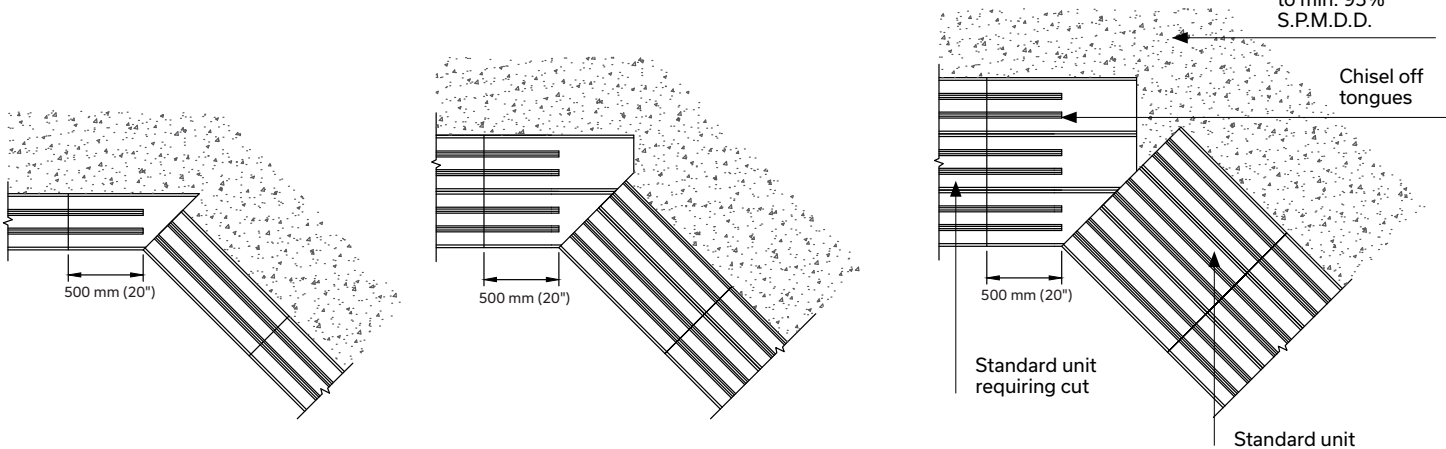

375 unit

750 unit

1125 unit

GEOGRID INSTALLATION

Instructions to follow for installing geogrids:

- > Follow the geogrid manufacturer instructions. Recommended type: Mirafi
- > Make sure the granular material is leveled with the geogrid once compacted
- > Place the geogrid by hand
- > Ensure the geogrid is oriented perpendicularly to the Grande Wall face
- > Pull tight on the geogrid while laying it down on the granular material to prevent wrinkles
- > Stake the geogrid down (on the granular material) before adding another layer of granular material

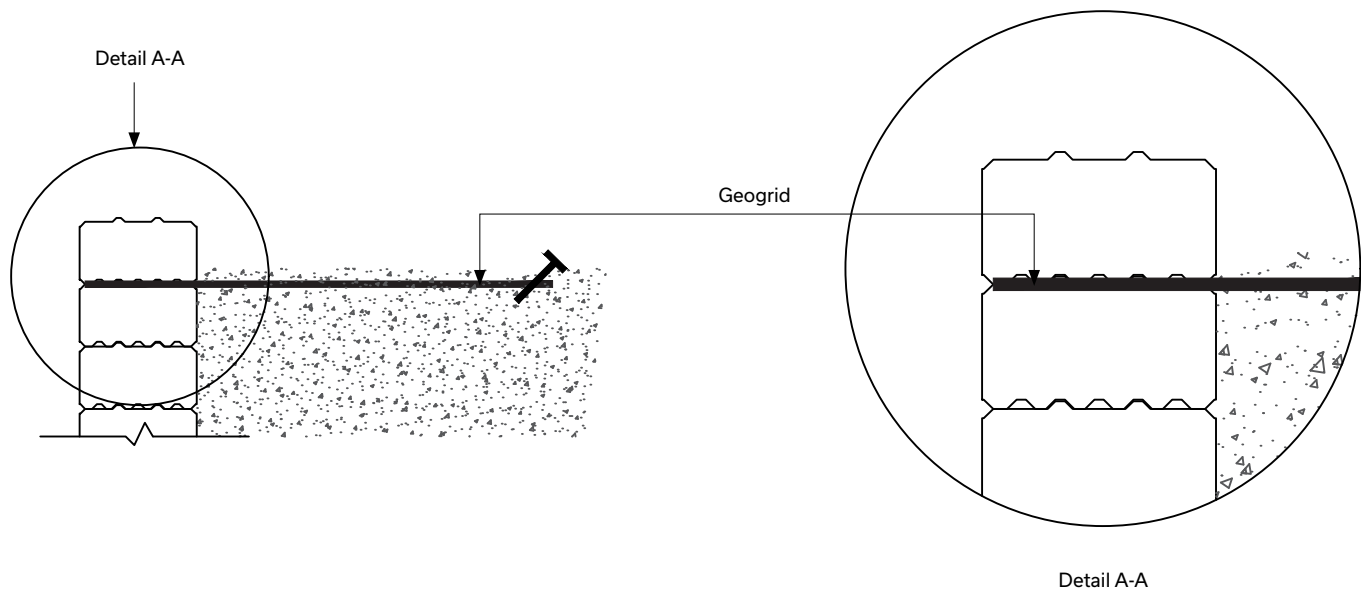

GRANDE WALL - INSTALLATION

CROSS-SECTION - GRANDE WALL 9° SETBACK GRAVITY 6 ROWS

Grande Wall 6 rows high (1.2 m or 3.9 ft.), including capping

- > 9° setback
- > Gravity
- > With 2.4 kPa surcharge
- > No slope behind the wall

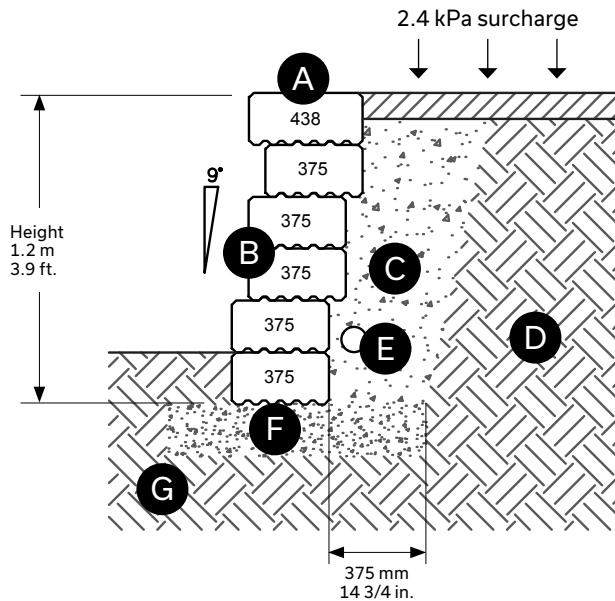

- A** Grande Wall - Capping 438 unit
- B** Grande Wall - 375 Standard: 5 rows high
- C** Granular "B" backfill material compacted to min. 95% S.P.M.D.D. Width: 375 mm - 14 3/4 in. behind the wall
- D** Undisturbed soil
- E** Perforated drain connected to services: 100 mm Ø - 4 in.
- F** Granular "A" material compacted to min. 98% S.P.M.D.D. Depth: 200 mm - 8 in. minimum
- G** Undisturbed soil or compacted granular foundation: 0 to 20 mm - 0 to 3/4 in. to obtain a min. bearing capacity of 150 kPa

Maximum gravity wall heights assume no slopes or surcharge behind the wall and that the wall retains sand or gravel ($\phi = 34$ degrees, $\gamma = 21 \text{ kN/m}^3$)

GRANDE WALL - INSTALLATION

CROSS-SECTION - GRANDE WALL 9° SETBACK GRAVITY 9 ROWS

Grande Wall 9 rows high (1.8 m or 5.9 ft.), including capping

- > 9° setback
- > Gravity
- > With 2.4 kPa surcharge
- > No slope behind the wall

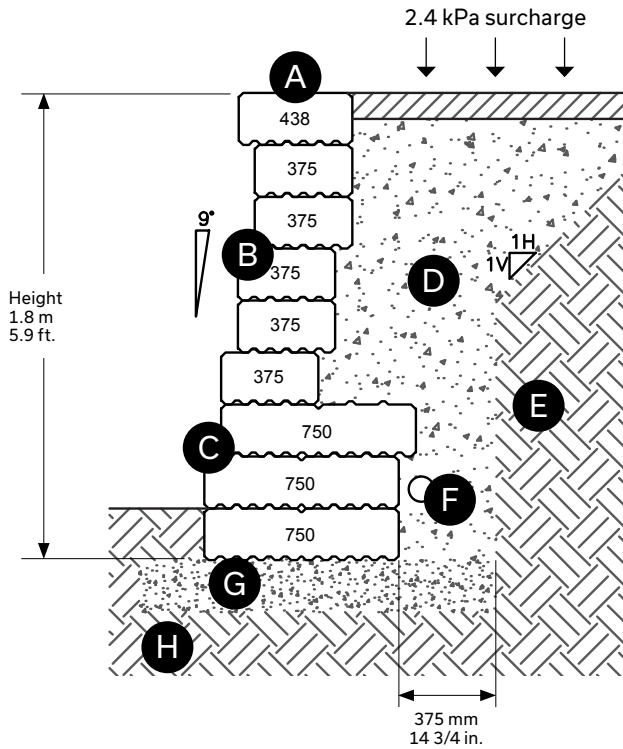

- A** Grande Wall – Capping 438 unit
- B** Grande Wall – 375 Standard: 5 rows high
- C** Grande Wall – 750 Standard: 3 rows high
- D** Granular "B" backfill material compacted to min. 95% S.P.M.D.D. Width: 375 mm - 14 3/4 in. behind the wall
- E** Undisturbed soil
- F** Perforated drain connected to services: 100 mm Ø - 4 in.
- G** Granular "A" material compacted to min. 98% S.P.M.D.D. Depth: 200 mm - 8 in. minimum
- H** Undisturbed soil or compacted granular foundation: 0 to 20 mm - 0 to 3/4 in. to obtain a min. bearing capacity of 150 kPa

Maximum gravity wall heights assume no slopes or surcharge behind the wall and that the wall retains sand or gravel ($\phi = 34$ degrees, $\gamma = 21 \text{ kN/m}^3$)

GRANDE WALL - INSTALLATION

CROSS-SECTION - GRANDE WALL 9° SETBACK GRAVITY 13 ROWS

Grande Wall 13 rows high (2.6 m or 8.53 ft.), including capping

- > 9° setback
- > Gravity
- > With 2.4 kPa surcharge
- > No slope behind the wall

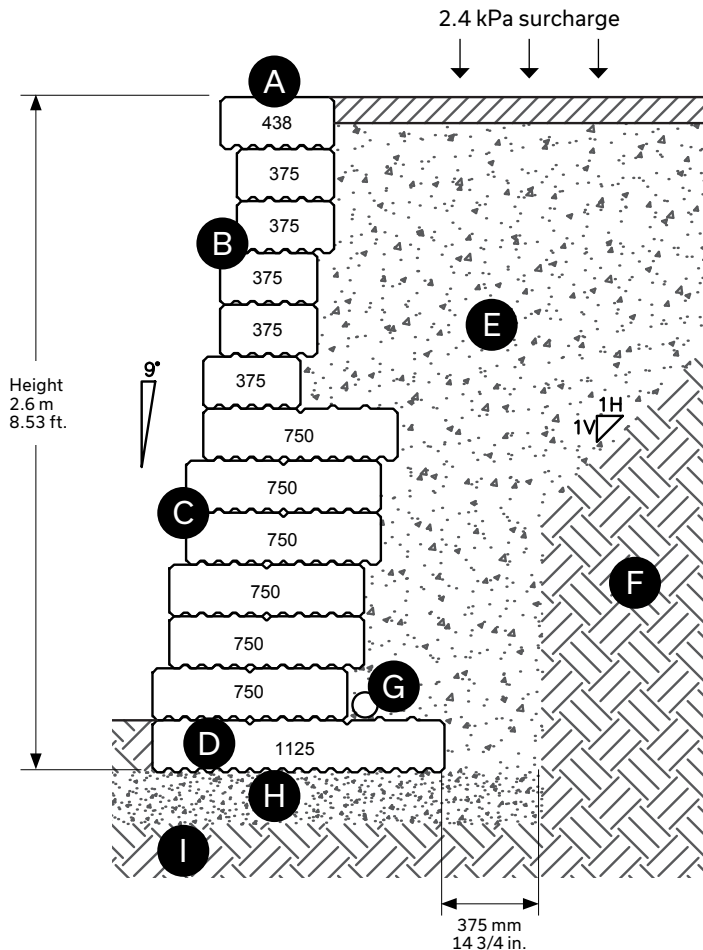

- A** Grande Wall – Capping 438 unit
- B** Grande Wall – 375 Standard: 5 rows high
- C** Grande Wall – 750 Standard: 6 rows high
- D** Grande Wall – 1125 Standard: 1 row high
- E** Granular "B" backfill material compacted to min. 95% S.P.M.D.D. - Width: 375 mm - 14 3/4 in. behind the wall
- F** Undisturbed soil
- G** Perforated drain connected to services: 100 mm Ø - 4 in.
- H** Granular "A" material compacted to min. 98% S.P.M.D.D. Depth: 200 mm - 8 in. minimum
- I** Undisturbed soil or compacted granular foundation: 0 to 20 mm - 0 to 3/4 in. to obtain a min. bearing capacity of 150 kPa

Maximum gravity wall heights assume no slopes or surcharge behind the wall and that the wall retains sand or gravel ($\phi = 34$ degrees, $\gamma = 21 \text{ kN/m}^3$)

GRANDE WALL - INSTALLATION

CROSS-SECTION - GRANDE WALL 9° SETBACK GRAVITY 15 ROWS

Grande Wall 15 rows high (3 m or 9.8 ft.), including capping

- > 9° setback
- > Gravity
- > With 2.4 kPa surcharge
- > No slope behind the wall

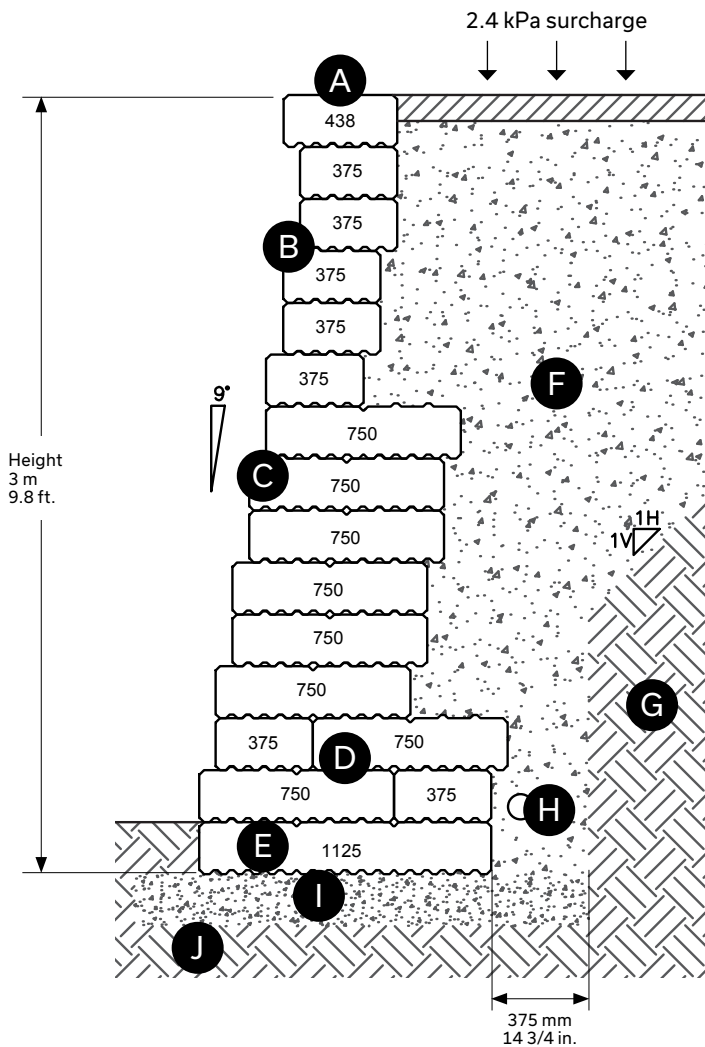

- Ⓐ Grande Wall – Capping 438 unit
- Ⓑ Grande Wall – 375 Standard: 5 rows high
- Ⓒ Grande Wall – 750 Standard: 6 rows high
- Ⓓ Grande Wall – 375 and 750 Standard: 2 rows high
- Ⓔ Grande Wall – 1125 Standard: 1 row high
- Ⓕ Granular "B" backfill material compacted to min. 95% S.P.M.D.D. - Width: 375 mm - 14 3/4 in. behind the wall
- Ⓖ Undisturbed soil
- Ⓗ Perforated drain connected to services: 100 mm Ø - 4 in.
- Ⓘ Granular "A" material compacted to min. 98% S.P.M.D.D. Depth: 200 mm - 8 in. minimum
- Ⓚ Undisturbed soil or compacted granular foundation: 0 to 20 mm - 0 to 3/4 in. to obtain a min. bearing capacity of 150 kPa

Maximum gravity wall heights assume no slopes or surcharge behind the wall and that the wall retains sand or gravel ($\phi = 34$ degrees, $\gamma = 21 \text{ kN/m}^3$)

GRANDE WALL - INSTALLATION

CROSS-SECTION - GRANDE WEDGE WALL 9° SETBACK GRAVITY 5 ROWS

Grande Wedge Wall 5 rows high (0.9 m or 2.95 ft.), including capping

- > 9° setback
- > Gravity
- > With 2.4 kPa surcharge
- > No slope behind the wall
- > Fill the cavities of the Grande Wedge units with clean stone

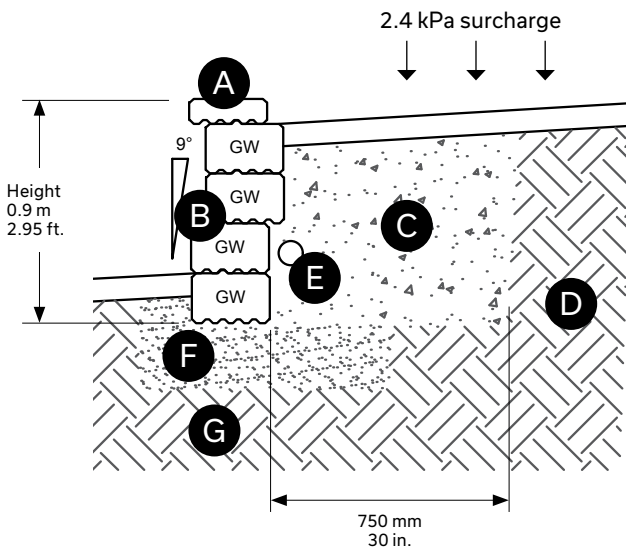

- Ⓐ Grande Wall – Capping 438 unit
- Ⓑ Grande Wall – Wedge Standard: 4 rows high
- Ⓒ Granular "B" backfill material compacted to min. 95% S.P.M.D.D. Width: 750 mm - 29 1/2 in. behind the wall
- Ⓓ Undisturbed soil
- Ⓔ Perforated drain connected to services: 100 mm Ø - 4 in.
- Ⓕ Granular "A" material compacted to min. 98% S.P.M.D.D. Depth: 200 mm - 8 in. minimum
- Ⓖ Undisturbed soil or compacted granular foundation: 0 to 20 mm - 0 to 3/4 in. to obtain a min. bearing capacity of 150 kPa

Grande Wedge Wall units are required to create curves with Grande Wall. Permacon is able to provide you with a customized standard cut. For more information, please contact your Permacon representative or send an inquiry directly to our website.

Maximum gravity wall heights assume no slopes or surcharge behind the wall and that the wall retains sand or gravel ($\phi = 34$ degrees, $\gamma = 21 \text{ kN/m}^3$)

GRANDE WALL - INSTALLATION

CROSS-SECTION - GRANDE WALL 17° SETBACK GRAVITY 8 ROWS

Grande Wall 8 rows high (1.6 m or 5.2 ft.), including capping

- > 17° setback
- > Gravity
- > With 2.4 kPa surcharge
- > No slope behind the wall

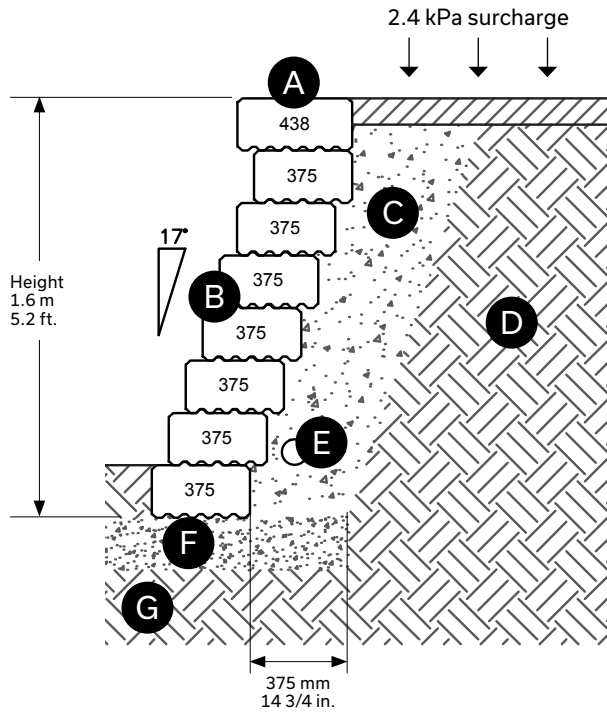

- Ⓐ Grande Wall – Capping 438 unit
- Ⓑ Grande Wall – 375 Standard: 7 rows high
- Ⓒ Granular "B" backfill material compacted to min. 95% S.P.M.D.D. Width: 375 mm - 14 3/4 in. behind the wall
- Ⓓ Undisturbed soil
- Ⓔ Perforated drain connected to services: 100 mm Ø - 4 in.
- Ⓕ Granular "A" material compacted to min. 98% S.P.M.D.D. Depth: 200 mm - 8 in. minimum
- Ⓖ Undisturbed soil or compacted granular foundation: 0 to 20 mm - 0 to 3/4 in. to obtain a min. bearing capacity of 150 kPa

Maximum gravity wall heights assume no slopes or surcharge behind the wall and that the wall retains sand or gravel ($\phi = 34$ degrees, $\gamma = 21 \text{ kN/m}^3$)

GRANDE WALL - INSTALLATION

CROSS-SECTION - GRANDE WALL 17° SETBACK GRAVITY 10 ROWS

Grande Wall 10 rows high (2 m or 6.6 ft.), including capping

- > 17° setback
- > Gravity
- > With 2.4 kPa surcharge
- > No slope behind the wall

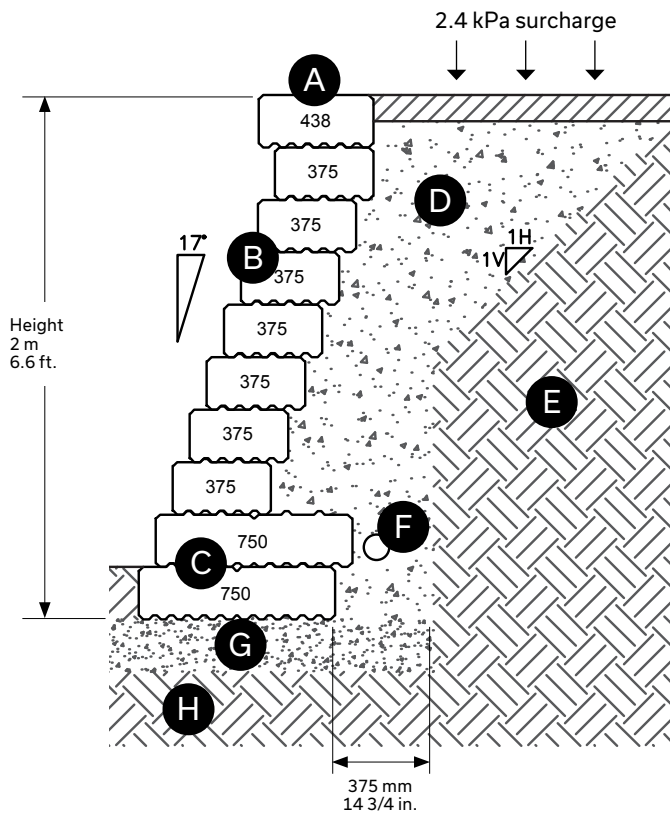

- A** Grande Wall - Capping 438 unit
- B** Grande Wall - 375 Standard: 7 rows high
- C** Grande Wall - 750 Standard: 2 rows high
- D** Granular "B" backfill material compacted to min. 95% S.P.M.D.D. Width: 375 mm - 14 3/4 in. behind the wall
- E** Undisturbed soil
- F** Perforated drain connected to services: 100 mm Ø - 4 in.
- G** Granular "A" material compacted to min. 98% S.P.M.D.D. Depth: 200 mm - 8 in. minimum
- H** Undisturbed soil or compacted granular foundation: 0 to 20 mm - 0 to 3/4 in. to obtain a min. bearing capacity of 150 kPa

Maximum gravity wall heights assume no slopes or surcharge behind the wall and that the wall retains sand or gravel ($\phi = 34$ degrees, $\gamma = 21 \text{ kN/m}^3$)

GRANDE WALL - INSTALLATION

CROSS-SECTION - GRANDE WALL 17° SETBACK GRAVITY 12 ROWS

Grande Wall 12 rows high (2.4 m or 7.9 ft.), including capping

- > 17° setback
- > Gravity
- > With 2.4 kPa surcharge
- > No slope behind the wall

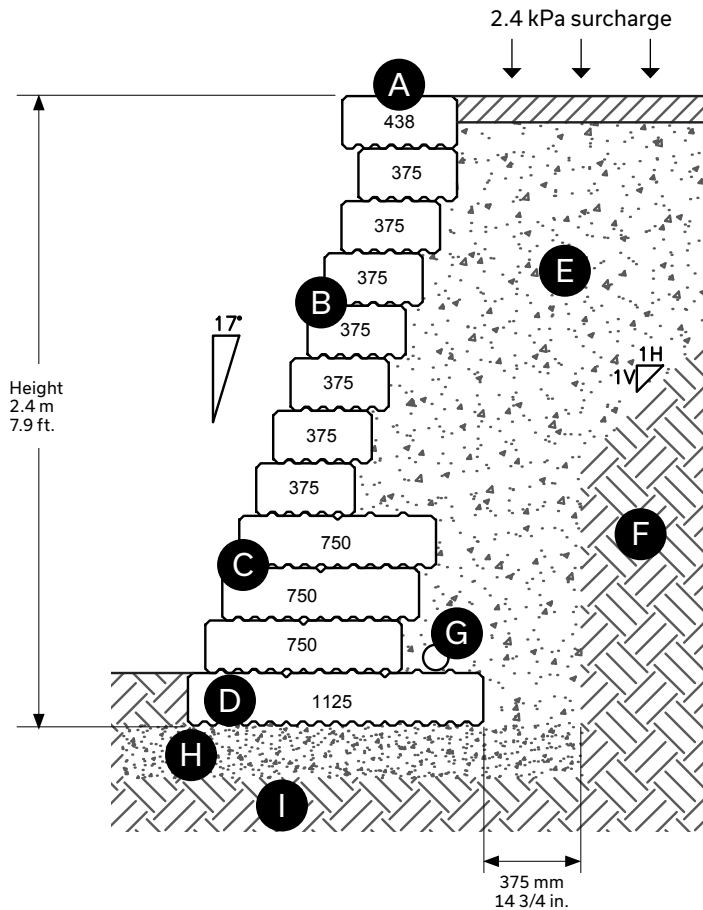

- A** Grande Wall - Capping 438 unit
- B** Grande Wall - 375 Standard: 7 rows high
- C** Grande Wall - 750 Standard: 3 rows high
- D** Grande Wall - 1125 Standard: 1 row high
- E** Granular "B" backfill material compacted to min. 95% S.P.M.D.D. - Width: 375 mm - 14 3/4 in. behind the wall
- F** Undisturbed soil
- G** Perforated drain connected to services: 100 mm Ø - 4 in.
- H** Granular "A" material compacted to min. 98% S.P.M.D.D. Depth: 200 mm - 8 in. minimum
- I** Undisturbed soil or compacted granular foundation: 0 to 20 mm - 0 to 3/4 in. to obtain a min. bearing capacity of 150 kPa

Maximum gravity wall heights assume no slopes or surcharge behind the wall and that the wall retains sand or gravel ($\phi = 34$ degrees, $\gamma = 21 \text{ kN/m}^3$)

GRANDE WALL - INSTALLATION

CROSS-SECTION - GRANDE WEDGE WALL 17° SETBACK GRAVITY 7 ROWS

Grande Wedge Wall 7 rows high (1.3 m or 4.27 ft.), including capping

- > 17° setback
- > Gravity
- > With 2.4 kPa surcharge
- > No slope behind the wall
- > Fill the cavities of the Grande Wedge units with clean stone

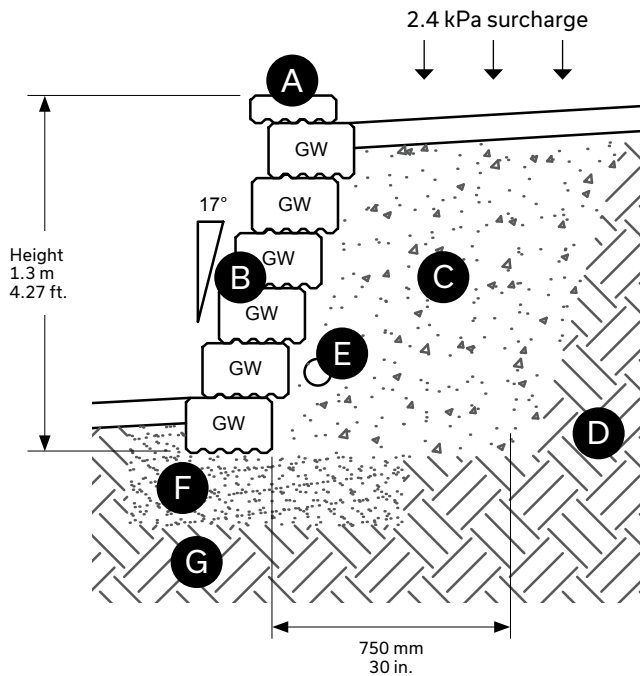

- A** Grande Wall – Capping 438 unit
- B** Grande Wall – Wedge Standard: 6 rows high
- C** Granular "B" backfill material compacted to min. 95% S.P.M.D.D. Width: 750 mm - 29 1/2 in. behind the wall
- D** Undisturbed soil
- E** Perforated drain connected to services: 100 mm Ø - 4 in.
- F** Granular "A" material compacted to min. 98% S.P.M.D.D. Depth: 200 mm - 8 in. minimum
- G** Undisturbed soil or compacted granular foundation: 0 to 20 mm - 0 to 3/4 in. to obtain a min. bearing capacity of 150 kPa

Grande Wedge Wall units are required to create curves with Grande Wall. Permacon is able to provide you with a customized standard cut. For more information, please contact your Permacon representative or send an inquiry directly to our website.

Maximum gravity wall heights assume no slopes or surcharge behind the wall and that the wall retains sand or gravel ($\phi = 34$ degrees, $\gamma = 21 \text{ kN/m}^3$)

GRANDE WALL - INSTALLATION

CROSS-SECTION - GRANDE WALL STRAIGHT GRAVITY 5 ROWS

Grande Wall 5 rows high (1 m or 3.28 ft.), including capping

- > Straight
- > Gravity
- > With 2.4 kPa surcharge
- > No slope behind the wall

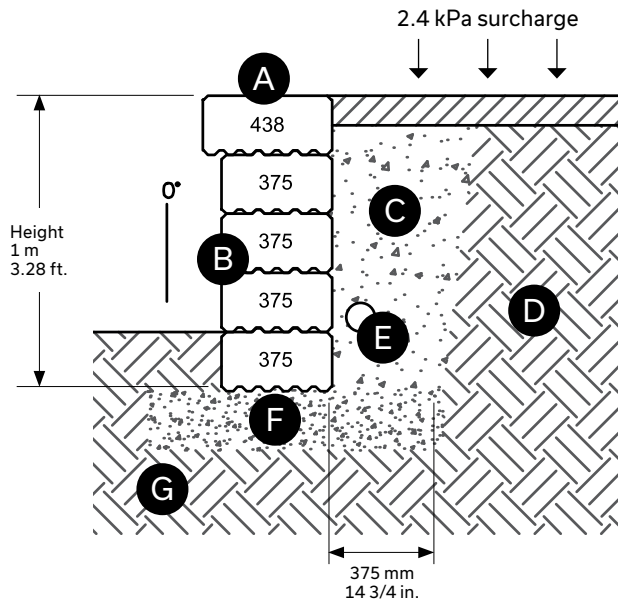

- Ⓐ Grande Wall – Capping 438 unit
- Ⓑ Grande Wall – 375 Standard: 4 rows high
- Ⓒ Granular "B" backfill material compacted to min. 95% S.P.M.D.D. Width: 375 mm - 14 3/4 in. behind the wall
- Ⓓ Undisturbed soil
- Ⓔ Perforated drain connected to services: 100 mm Ø - 4 in.
- Ⓕ Granular "A" material compacted to min. 98% S.P.M.D.D. Depth: 200 mm - 8 in. minimum
- Ⓖ Undisturbed soil or compacted granular foundation: 0 to 20 mm - 0 to 3/4 in. to obtain a min. bearing capacity of 150 kPa

Maximum gravity wall heights assume no slopes or surcharge behind the wall and that the wall retains sand or gravel ($\phi = 34$ degrees, $\gamma = 21 \text{ kN/m}^3$)

GRANDE WALL - INSTALLATION

CROSS-SECTION - GRANDE WALL STRAIGHT GRAVITY 8 ROWS

Grande Wall 5 rows high (1.6 m or 5.2 ft.), including capping

- > Straight
- > Gravity
- > With 2.4 kPa surcharge
- > No slope behind the wall

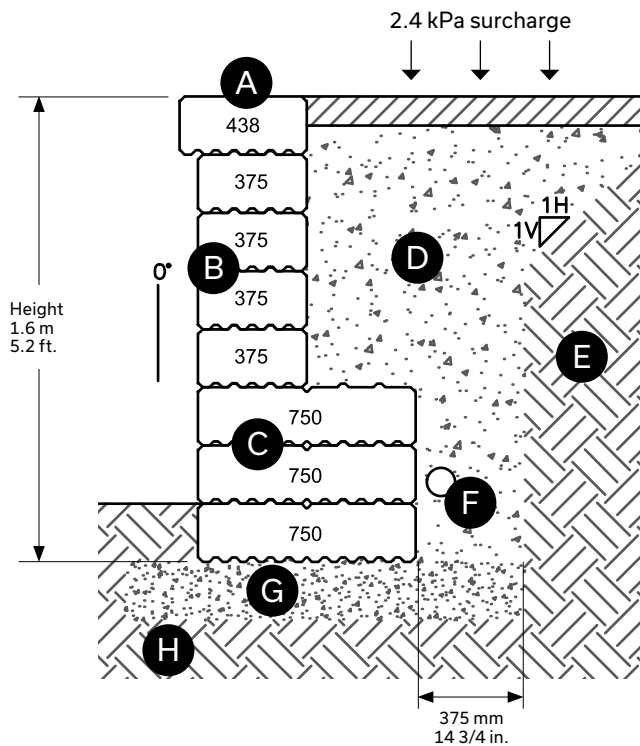

- Ⓐ Grande Wall - Capping 438 unit
- Ⓑ Grande Wall - 375 Standard: 4 rows high
- Ⓒ Grande Wall - 750 Standard: 3 rows high
- Ⓓ Granular "B" backfill material compacted to min. 95% S.P.M.D.D. Width: 375 mm - 14 3/4 in. behind the wall
- Ⓔ Undisturbed soil
- Ⓕ Perforated drain connected to services: 100 mm Ø - 4 in.
- Ⓖ Granular "A" material compacted to min. 98% S.P.M.D.D. Depth: 200 mm - 8 in. minimum
- Ⓗ Undisturbed soil or compacted granular foundation: 0 to 20 mm - 0 to 3/4 in. to obtain a min. bearing capacity of 150 kPa

Maximum gravity wall heights assume no slopes or surcharge behind the wall and that the wall retains sand or gravel ($\phi = 34$ degrees, $\gamma = 21 \text{ kN/m}^3$)

GRANDE WALL - INSTALLATION

CROSS-SECTION - GRANDE WALL STRAIGHT GRAVITY 12 ROWS

Grande Wall 12 rows high (2.4 m or 7.9 ft.), including capping

- > Straight
- > Gravity
- > With 2.4 kPa surcharge
- > No slope behind the wall

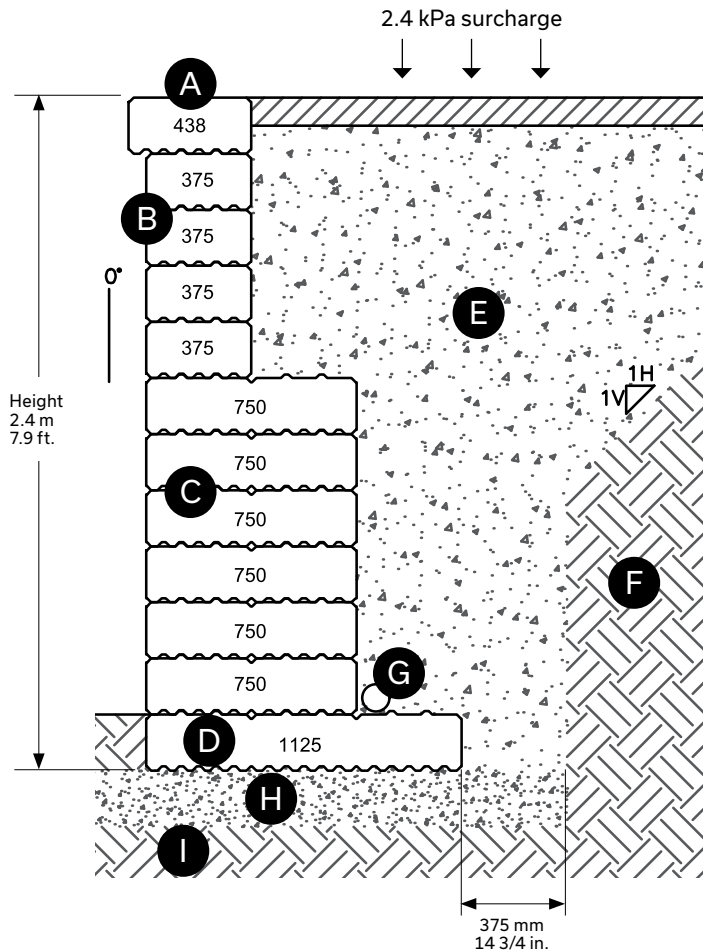

- A** Grande Wall - Capping 438 unit
- B** Grande Wall - 375 Standard: 4 rows high
- C** Grande Wall - 750 Standard: 6 rows high
- D** Grande Wall - 1125 Standard: 1 row high
- E** Granular "B" backfill material compacted to min. 95% S.P.M.D.D. - Width: 375 mm - 14 3/4 in. behind the wall
- F** Undisturbed soil
- G** Perforated drain connected to services: 100 mm Ø - 4 in.
- H** Granular "A" material compacted to min. 98% S.P.M.D.D. Depth: 200 mm - 8 in. minimum
- I** Undisturbed soil or compacted granular foundation: 0 to 20 mm - 0 to 3/4 in. to obtain a min. bearing capacity of 150 kPa

Maximum gravity wall heights assume no slopes or surcharge behind the wall and that the wall retains sand or gravel ($\phi = 34$ degrees, $\gamma = 21 \text{ kN/m}^3$)

GRANDE WALL - INSTALLATION

CROSS-SECTION - GRANDE WALL STRAIGHT GRAVITY 15 ROWS

Grande Wall 15 rows high (3 m or 9.8 ft.), including capping

- > Straight
- > Gravity
- > With 2.4 kPa surcharge
- > No slope behind the wall

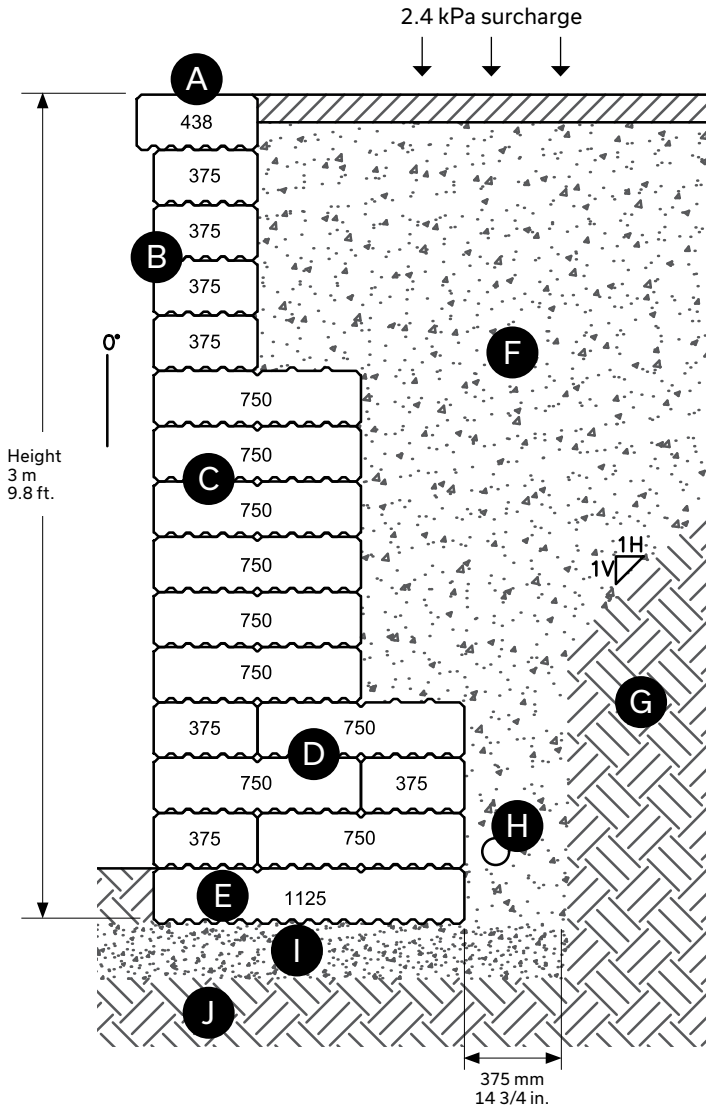

- Ⓐ Grande Wall – Capping 438 unit
- Ⓑ Grande Wall – 375 Standard: 4 rows high
- Ⓒ Grande Wall – 750 Standard: 6 rows high
- Ⓓ Grande Wall – 375 and 750 Standard: 3 rows high
- Ⓔ Grande Wall – 1125 Standard: 1 row high
- Ⓕ Granular "B" backfill material compacted to min. 95% S.P.M.D.D. - Width: 375 mm - 14 3/4 in. behind the wall
- Ⓖ Undisturbed soil
- Ⓗ Perforated drain connected to services: 100 mm Ø - 4 in.
- Ⓘ Granular "A" material compacted to min. 98% S.P.M.D.D. Depth: 200 mm - 8 in. minimum
- Ⓚ Undisturbed soil or compacted granular foundation: 0 to 20 mm - 0 to 3/4 in. to obtain a min. bearing capacity of 150 kPa

Maximum gravity wall heights assume no slopes or surcharge behind the wall and that the wall retains sand or gravel ($\phi = 34$ degrees, $\gamma = 21 \text{ kN/m}^3$)

GRANDE WALL - INSTALLATION

CROSS-SECTION - GRANDE WEDGE WALL STRAIGHT GRAVITY 4 ROWS

Grande Wedge Wall 4 rows high (0.7 m or 2.3 ft.), including capping

- > Straight
- > Gravity
- > With 2.4 kPa surcharge
- > No slope behind the wall
- > Fill the cavities of the Grande Wedge units with clean stone

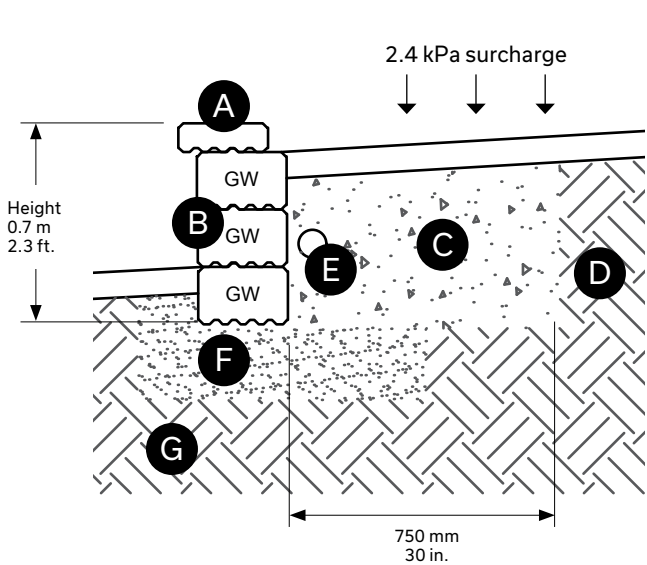

- Ⓐ Grande Wall - Capping 438 unit
- Ⓑ Grande Wall - Wedge Standard: 3 rows high
- Ⓒ Granular "B" backfill material compacted to min. 95% S.P.M.D.D. - Width: 750 mm - 29 1/2 in. behind the wall
- Ⓓ Undisturbed soil
- Ⓔ Perforated drain connected to services: 100 mm Ø - 4 in.
- Ⓕ Granular "A" material compacted to min. 98% S.P.M.D.D. Depth: 200 mm - 8 in. minimum
- Ⓖ Undisturbed soil or compacted granular foundation: 0 to 20 mm - 0 to 3/4 in. to obtain a min. bearing capacity of 150 kPa

Grande Wedge Wall units are required to create curves with Grande Wall. Permacon is able to provide you with a customized standard cut. For more information, please contact your Permacon representative or send an inquiry directly to our website.

Maximum gravity wall heights assume no slopes or surcharge behind the wall and that the wall retains sand or gravel ($\phi = 34$ degrees, $\gamma = 21 \text{ kN/m}^3$)

GRANDE WALL - INSTALLATION

CROSS-SECTION - GRANDE WALL 9° SETBACK REINFORCED 9 ROWS

Grande Wall 9 rows high (1.8 m or 5.9 ft), including capping

- > 9° setback
- > Reinforced with geogrid. Recommended geogrid: Miragrid 3XT
- > With 2.4 kPa surcharge
- > No slope behind the wall

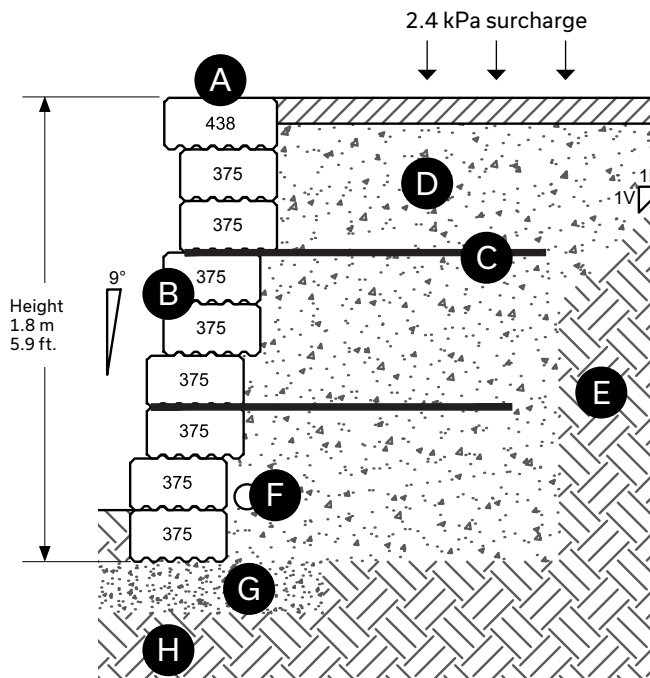

- Ⓐ Grande Wall – Capping 438 unit
- Ⓑ Grande Wall – 375 Standard: 8 rows high
- Ⓒ Geogrid: 1.4 m - 4.6 ft. length
- Ⓓ Granular "B" backfill material compacted to min. 95% S.P.M.D.D. Width: 375 mm - 14 3/4 in. behind the wall
- Ⓔ Undisturbed soil
- Ⓕ Perforated drain connected to services: 100 mm Ø - 4 in.
- Ⓖ Granular "A" material compacted to min. 98% S.P.M.D.D. Depth: 200 mm - 8 in. minimum
- Ⓗ Undisturbed soil or compacted granular foundation: 0 to 20 mm - 0 to 3/4 in. to obtain a min. bearing capacity of 150 kPa

Maximum gravity wall heights assume no slopes or surcharge behind the wall and that the wall retains sand or gravel ($\phi = 34$ degrees, $\gamma = 21 \text{ kN/m}^3$)

GRANDE WALL - INSTALLATION

CROSS-SECTION - GRANDE WALL 9° SETBACK REINFORCED 12 ROWS

Grande Wall 12 rows high (2.4 m or 7.9 ft), including capping

- > 9° setback
- > Reinforced with geogrid. Recommended geogrid: Miragrid 3XT
- > With 2.4 kPa surcharge
- > No slope behind the wall

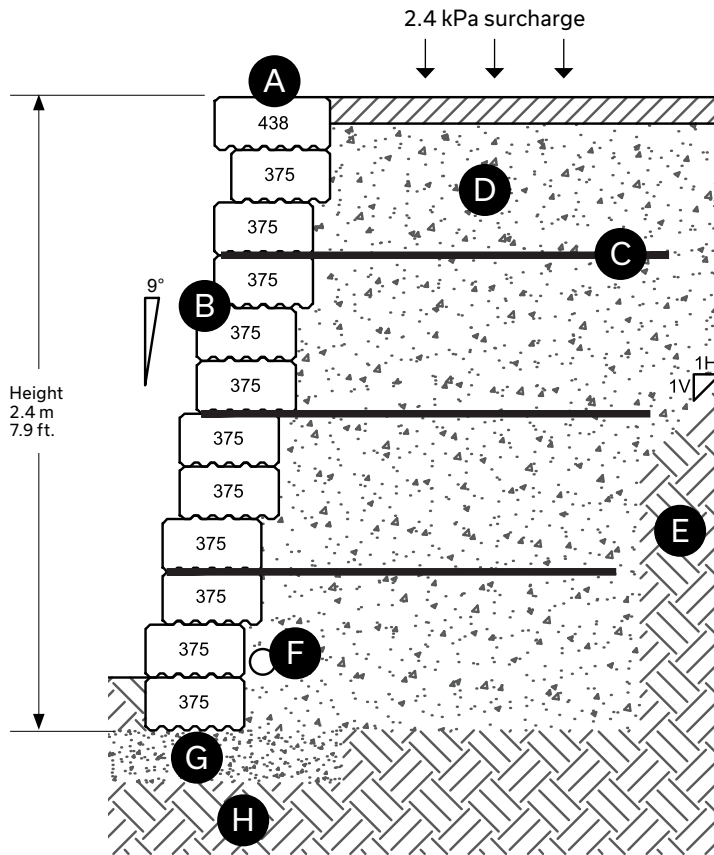

- A** Grande Wall – Capping 438 unit
- B** Grande Wall – 375 Standard: 11 rows high
- C** Geogrid: 1.7 m - 5.6 ft. minimum length
- D** Granular "B" backfill material compacted to min. 95% S.P.M.D.D. - Width: 375 mm - 14 3/4 in. behind the wall
- E** Undisturbed soil
- F** Perforated drain connected to services: 100 mm Ø - 4 in.
- G** Granular "A" material compacted to min. 98% S.P.M.D.D. Depth: 200 mm - 8 in. minimum
- H** Undisturbed soil or compacted granular foundation: 0 to 20 mm - 0 to 3/4 in. to obtain a min. bearing capacity of 150 kPa

Maximum gravity wall heights assume no slopes or surcharge behind the wall and that the wall retains sand or gravel ($\phi = 34$ degrees, $\gamma = 21 \text{ kN/m}^3$)

GRANDE WALL - INSTALLATION

CROSS-SECTION - GRANDE WALL 9° SETBACK REINFORCED 15 ROWS

Grande Wall 15 rows high (3 m or 9.8 ft), including capping

- > 9° setback
- > Reinforced with geogrid. Recommended geogrid: Miragrid 3XT
- > With 2.4 kPa surcharge
- > No slope behind the wall

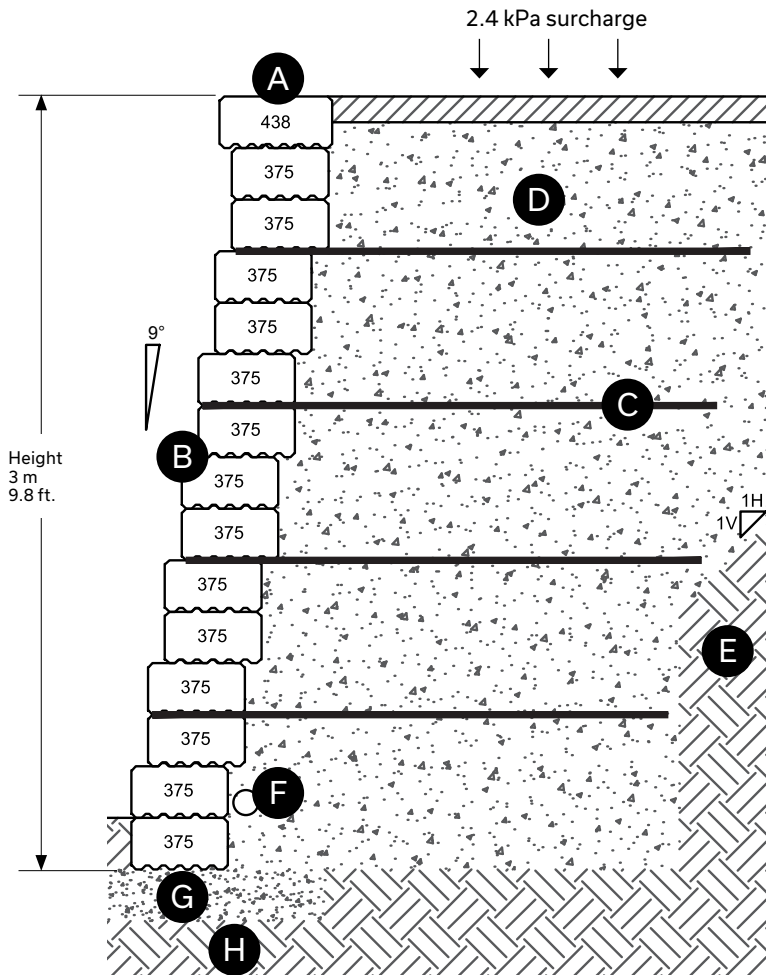

- A** Grande Wall – Capping 438 unit
- B** Grande Wall – 375 Standard: 14 rows high
- C** Geogrid: 2 m - 6,6 ft. minimum length
- D** Granular "B" backfill material compacted to min. 95% S.P.M.D.D. - Width: 375 mm - 14 3/4 in. behind the wall
- E** Undisturbed soil
- F** Perforated drain connected to services: 100 mm Ø - 4 in.
- G** Granular "A" material compacted to min. 98% S.P.M.D.D. - Depth: 200 mm - 8 in. minimum
- H** Undisturbed soil or compacted granular foundation: 0 to 20 mm - 0 to 3/4 in. to obtain a min. bearing capacity of 150 kPa

Maximum gravity wall heights assume no slopes or surcharge behind the wall and that the wall retains sand or gravel ($\phi = 34$ degrees, $\gamma = 21 \text{ kN/m}^3$)

GRANDE WALL - INSTALLATION

CROSS-SECTION - GRANDE WEDGE WALL 9° SETBACK REINFORCED 8 ROWS

Grande Wedge Wall 8 rows high (1.5 m or 4.92 ft.), including capping

- > 9° setback
- > Gravity
- > With 2.4 kPa surcharge
- > No slope behind the wall
- > Fill the cavities of the Grande Wedge units with clean stone

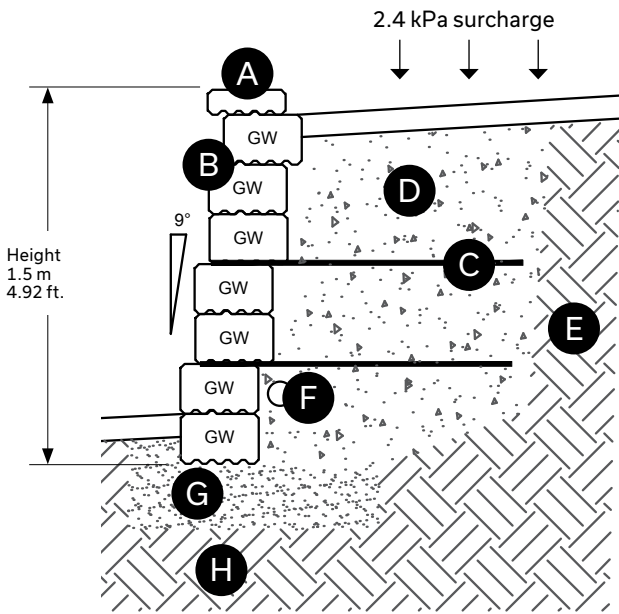

- Ⓐ Grande Wall – Capping 438 unit
- Ⓑ Grande Wall – Wedge Standard: 7 rows high
- Ⓒ Geogrid: 1.3 m - 4.3 ft. minimum length
- Ⓓ Granular "B" backfill material compacted to min. 95% S.P.M.D.D. Width: 750 mm - 29 1/2 in. behind the wall
- Ⓔ Undisturbed soil
- Ⓕ Perforated drain connected to services: 100 mm Ø - 4 in.
- Ⓖ Granular "A" material compacted to min. 98% S.P.M.D.D. Depth: 200 mm - 8 in. minimum
- Ⓗ Undisturbed soil or compacted granular foundation: 0 to 20 mm - 0 to 3/4 in. to obtain a min. bearing capacity of 150 kPa

Grande Wedge Wall units are required to create curves with Grande Wall. Permacon is able to provide you with a customized standard cut. For more information, please contact your Permacon representative or send an inquiry directly to our website.

Maximum gravity wall heights assume no slopes or surcharge behind the wall and that the wall retains sand or gravel ($\phi = 34$ degrees, $\gamma = 21 \text{ kN/m}^3$)

GRANDE WALL - INSTALLATION

CROSS-SECTION - GRANDE WEDGE WALL 9° SETBACK REINFORCED 13 ROWS

Grande Wedge Wall 13 rows high (2.5 m or 8.2 ft.), including capping

- > 9° setback
- > Gravity
- > With 2.4 kPa surcharge
- > No slope behind the wall
- > Fill the cavities of the Grande Wedge units with clean stone

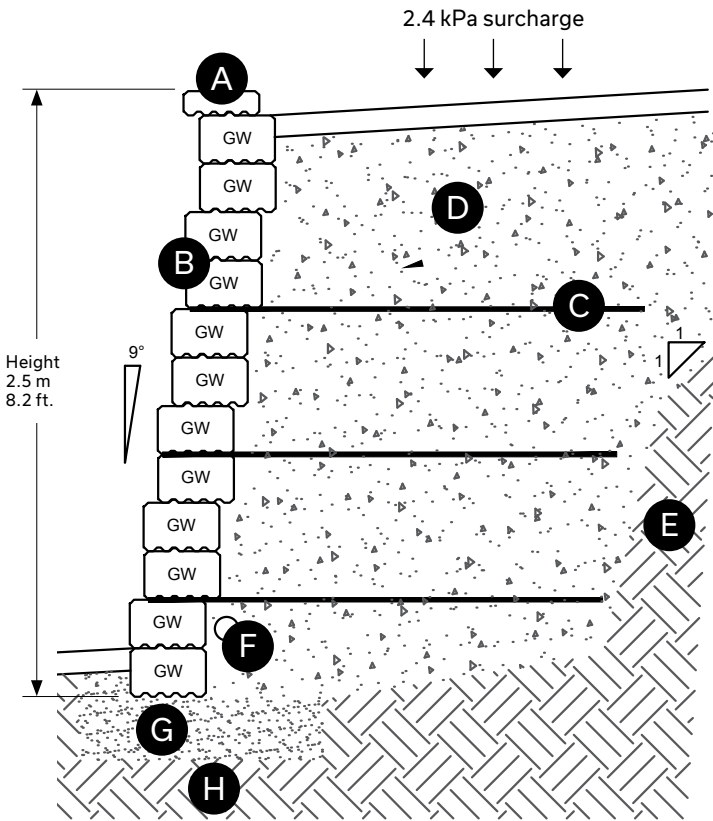

- A Grande Wall – Capping 438 unit
- B Grande Wall – Wedge Standard: 12 rows high
- C Geogrid: 1.5 m - 4.9 ft. minimum length
- D Granular "B" backfill material compacted to min. 95% S.P.M.D.D. - Width: 750 mm - 29 1/2 in. behind the wall
- E Undisturbed soil
- F Perforated drain connected to services: 100 mm Ø - 4 in.
- G Granular "A" material compacted to min. 98% S.P.M.D.D. Depth: 200 mm - 8 in. minimum
- H Undisturbed soil or compacted granular foundation: 0 to 20 mm - 0 to 3/4 in. to obtain a min. bearing capacity of 150 kPa

Grande Wedge Wall units are required to create curves with Grande Wall. Permacon is able to provide you with a customized standard cut. For more information, please contact your Permacon representative or send an inquiry directly to our website.

Maximum gravity wall heights assume no slopes or surcharge behind the wall and that the wall retains sand or gravel ($\phi = 34$ degrees, $\gamma = 21 \text{ kN/m}^3$)

GRANDE WALL - INSTALLATION

CROSS-SECTION - GRANDE WEDGE WALL 9° SETBACK REINFORCED 16 ROWS

Grande Wedge Wall 16 rows high (3.1 m or 10.17 ft.), including capping

- > 9° setback
- > Gravity
- > With 2.4 kPa surcharge
- > No slope behind the wall
- > Fill the cavities of the Grande Wedge units with clean stone

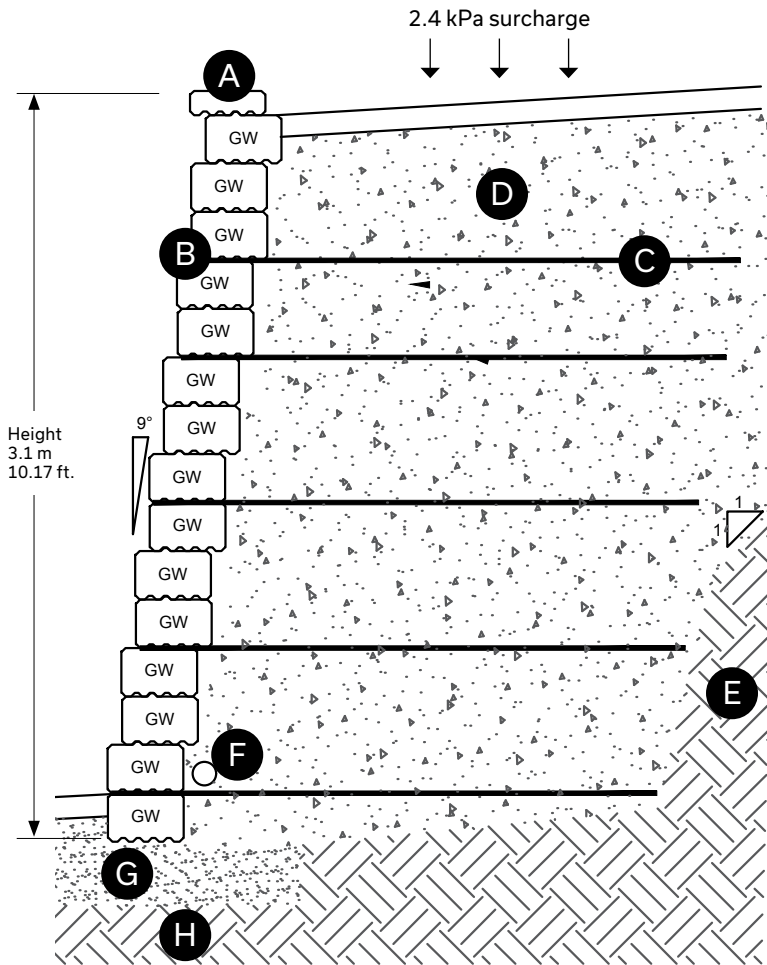

- A** Grande Wall – Capping 438 unit
- B** Grande Wall – Wedge Standard: 15 rows high
- C** Geogrid: 1.8 m - 5.9 ft. minimum length
- D** Granular "B" backfill material compacted to min. 95% S.P.M.D.D. - Width: 750 mm - 29 1/2 in. behind the wall
- E** Undisturbed soil
- F** Perforated drain connected to services: 100 mm Ø - 4 in.
- G** Granular "A" material compacted to min. 98% S.P.M.D.D. - Depth: 200 mm - 8 in. minimum
- H** Undisturbed soil or compacted granular foundation: 0 to 20 mm - 0 to 3/4 in. to obtain a min. bearing capacity of 150 kPa

Grande Wedge Wall units are required to create curves with Grande Wall. Permacon is able to provide you with a customized standard cut. For more information, please contact your Permacon representative or send an inquiry directly to our website.

Maximum gravity wall heights assume no slopes or surcharge behind the wall and that the wall retains sand or gravel ($\phi = 34$ degrees, $\gamma = 21 \text{ kN/m}^3$)

GRANDE WALL - INSTALLATION

CROSS-SECTION - GRANDE WALL 17° SETBACK REINFORCED 9 ROWS

Grande Wall 9 rows high (1.8 m or 5.9 ft.), including capping

- > 17° setback
- > Reinforced with geogrid. Recommended geogrid: Miragrid 3XT
- > With 2.4 kPa surcharge
- > No slope behind the wall

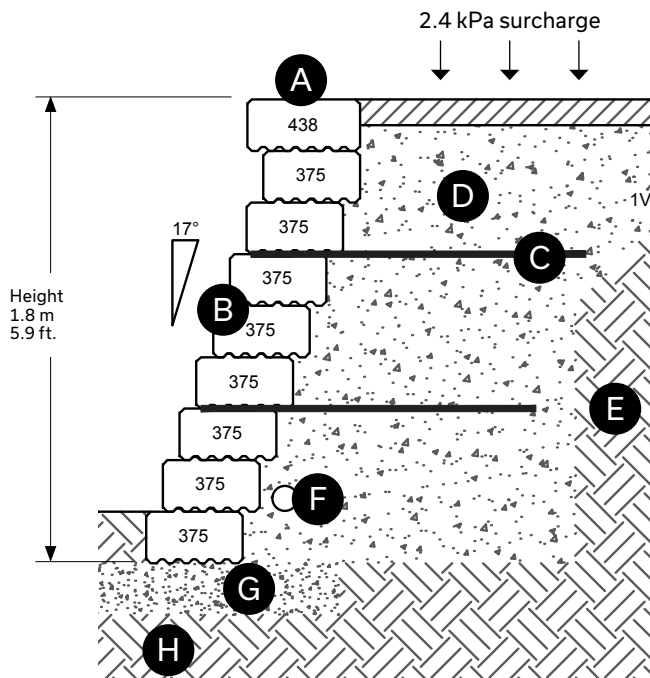

- A** Grande Wall – Capping 438 unit
- B** Grande Wall – 375 Standard: 8 rows high
- C** Geogrid: 1.4 m - 4.6 ft. minimum length
- D** Granular "B" backfill material compacted to min. 95% S.P.M.D.D. Width: 375 mm - 14 3/4 in. behind the wall
- E** Undisturbed soil
- F** Perforated drain connected to services: 100 mm Ø - 4 in.
- G** Granular "A" material compacted to min. 98% S.P.M.D.D. Depth: 200 mm - 8 in. minimum
- H** Undisturbed soil or compacted granular foundation: 0 to 20 mm - 0 to 3/4 in. to obtain a min. bearing capacity of 150 kPa

Maximum gravity wall heights assume no slopes or surcharge behind the wall and that the wall retains sand or gravel ($\phi = 34$ degrees, $\gamma = 21 \text{ kN/m}^3$)

GRANDE WALL - INSTALLATION

CROSS-SECTION - GRANDE WALL 17° SETBACK REINFORCED 12 ROWS

Grande Wall 12 rows high (2.4 m or 7.9 ft.), including capping

- > 17° setback
- > Reinforced with geogrid. Recommended geogrid: Miragrid 3XT
- > With 2.4 kPa surcharge
- > No slope behind the wall

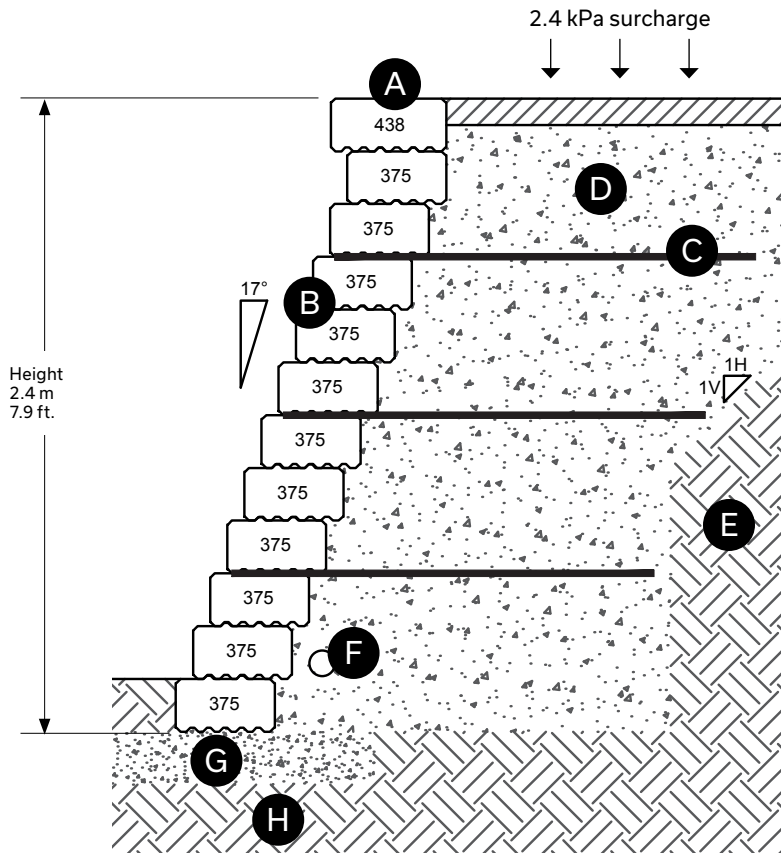

- A** Grande Wall – Capping 438 unit
- B** Grande Wall – 375 Standard: 11 rows high
- C** Geogrid: 1.6 m - 5.2 ft. minimum length
- D** Granular "B" backfill material compacted to min. 95% S.P.M.D.D. - Width: 375 mm - 14 3/4 in. behind the wall
- E** Undisturbed soil
- F** Perforated drain connected to services: 100 mm O - 4 in.
- G** Granular "A" material compacted to min. 98% S.P.M.D.D. - Depth: 200 mm - 8 in. minimum
- H** Undisturbed soil or compacted granular foundation: 0 to 20 mm - 0 to 3/4 in. to obtain a min. bearing capacity of 150 kPa

Maximum gravity wall heights assume no slopes or surcharge behind the wall and that the wall retains sand or gravel ($\phi = 34$ degrees, $\gamma = 21 \text{ kN/m}^3$)

GRANDE WALL - INSTALLATION

CROSS-SECTION - GRANDE WALL 17° SETBACK REINFORCED 15 ROWS

Grande Wall 15 rows high (3 m or 9.8 ft.), including capping

- > 17° setback
- > Reinforced with geogrid. Recommended geogrid: Miragrid 3XT
- > With 2.4 kPa surcharge
- > No slope behind the wall

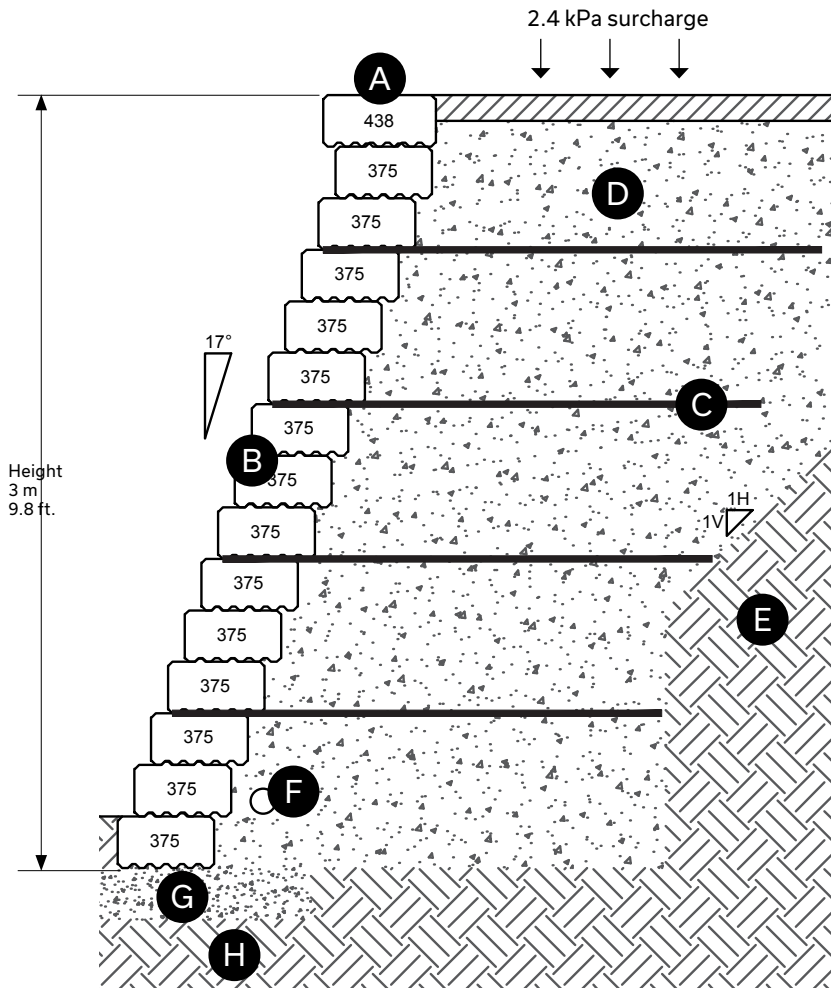

- A** Grande Wall – Capping 438 unit
- B** Grande Wall – 375 Standard: 14 rows high
- C** Geogrid: 1.9 m - 6.2 ft. minimum length
- D** Granular "B" backfill material compacted to min. 95% S.P.M.D.D. - Width: 375 mm - 14 3/4 in. behind the wall
- E** Undisturbed soil
- F** Perforated drain connected to services: 100 mm O - 4 in.
- G** Granular "A" material compacted to min. 98% S.P.M.D.D. - Depth: 200 mm - 8 in. minimum
- H** Undisturbed soil or compacted granular foundation: 0 to 20 mm - 0 to 3/4 in. to obtain a min. bearing capacity of 150 kPa

Maximum gravity wall heights assume no slopes or surcharge behind the wall and that the wall retains sand or gravel ($\phi = 34$ degrees, $\gamma = 21 \text{ kN/m}^3$)

GRANDE WALL - INSTALLATION

CROSS-SECTION - GRANDE WEDGE WALL 17° SETBACK REINFORCED 8 ROWS

Grande Wedge Wall 8 rows high (1.5 m or 4.92 ft.), including capping

- > 17° setback
- > Reinforced with geogrid. Recommended geogrid: Miragrid 3XT
- > With 2.4 kPa surcharge
- > No slope behind the wall
- > Fill the cavities of the Grande Wedge units with clean stone

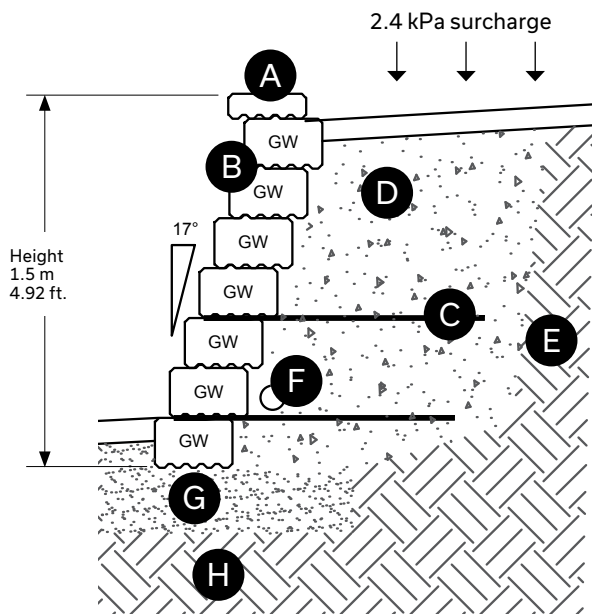

- Ⓐ Grande Wall – Capping 438 unit
- Ⓑ Grande Wall – Wedge Standard: 7 rows high
- Ⓒ Geogrid: 1.3 m - 4.3 ft. minimum length
- Ⓓ Granular "B" backfill material compacted to min. 95% S.P.M.D.D. Width: 750 mm - 29 1/2 in. behind the wall
- Ⓔ Undisturbed soil
- Ⓕ Perforated drain connected to services: 100 mm Ø - 4 in.
- Ⓖ Granular "A" material compacted to min. 98% S.P.M.D.D. Depth: 200 mm - 8 in. minimum
- Ⓗ Undisturbed soil or compacted granular foundation: 0 to 20 mm - 0 to 3/4 in. to obtain a min. bearing capacity of 150 kPa

Grande Wedge Wall units are required to create curves with Grande Wall. Permacon is able to provide you with a customized standard cut. For more information, please contact your Permacon representative or send an inquiry directly to our website.

Maximum gravity wall heights assume no slopes or surcharge behind the wall and that the wall retains sand or gravel ($\phi = 34$ degrees, $\gamma = 21 \text{ kN/m}^3$)

GRANDE WALL - INSTALLATION

CROSS-SECTION - GRANDE WEDGE WALL 17° SETBACK REINFORCED 13 ROWS

Grande Wedge Wall 13 rows high (2.5 m or 8.2 ft.), including capping

- > 17° setback
- > Reinforced with geogrid. Recommended geogrid: Miragrid 3XT
- > With 2.4 kPa surcharge
- > No slope behind the wall
- > Fill the cavities of the Grande Wedge units with clean stone

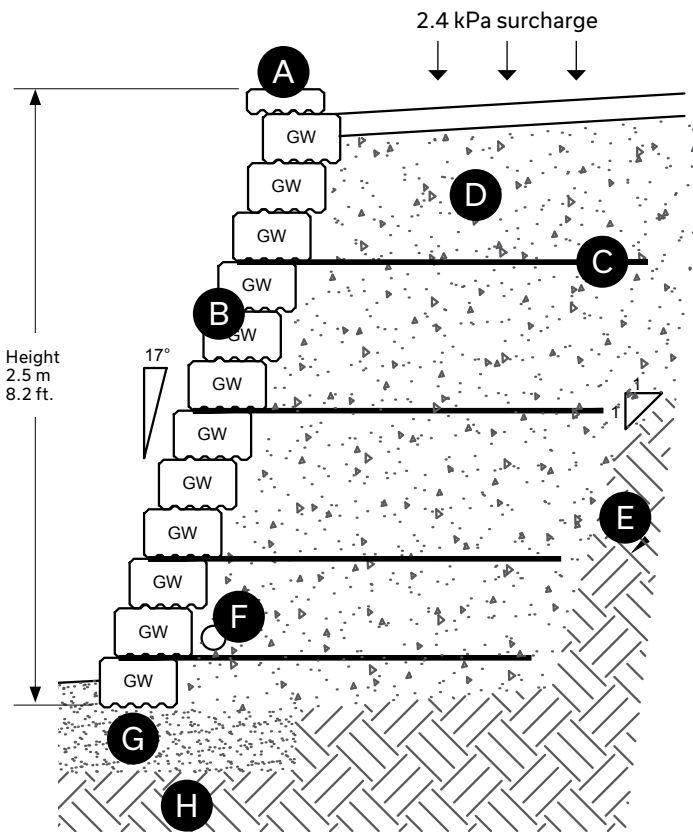

- Ⓐ Grande Wall – Capping 438 unit
- Ⓑ Grande Wall – Wedge Standard: 12 rows high
- Ⓒ Geogrid: 1.5 m - 4.9 ft. minimum length
- Ⓓ Granular "B" backfill material compacted to min. 95% S.P.M.D.D. - Width: 750 mm - 29 1/2 in. behind the wall
- Ⓔ Undisturbed soil
- Ⓕ Perforated drain connected to services: 100 mm Ø - 4 in.
- Ⓖ Granular "A" material compacted to min. 98% S.P.M.D.D. Depth: 200 mm - 8 in. minimum
- Ⓗ Undisturbed soil or compacted granular foundation: 0 to 20 mm - 0 to 3/4 in. to obtain a min. bearing capacity of 150 kPa

Grande Wedge Wall units are required to create curves with Grande Wall. Permacon is able to provide you with a customized standard cut. For more information, please contact your Permacon representative or send an inquiry directly to our website.

Maximum gravity wall heights assume no slopes or surcharge behind the wall and that the wall retains sand or gravel ($\phi = 34$ degrees, $\gamma = 21 \text{ kN/m}^3$)

GRANDE WALL - INSTALLATION

CROSS-SECTION - GRANDE WEDGE WALL 17° SETBACK REINFORCED 16 ROWS

Grande Wedge Wall 16 rows high (3.1 m or 10.17 ft.), including capping

- > 17° setback
- > Reinforced with geogrid. Recommended geogrid: Miragrid 3XT
- > With 2.4 kPa surcharge
- > No slope behind the wall
- > Fill the cavities of the Grande Wedge units with clean stone

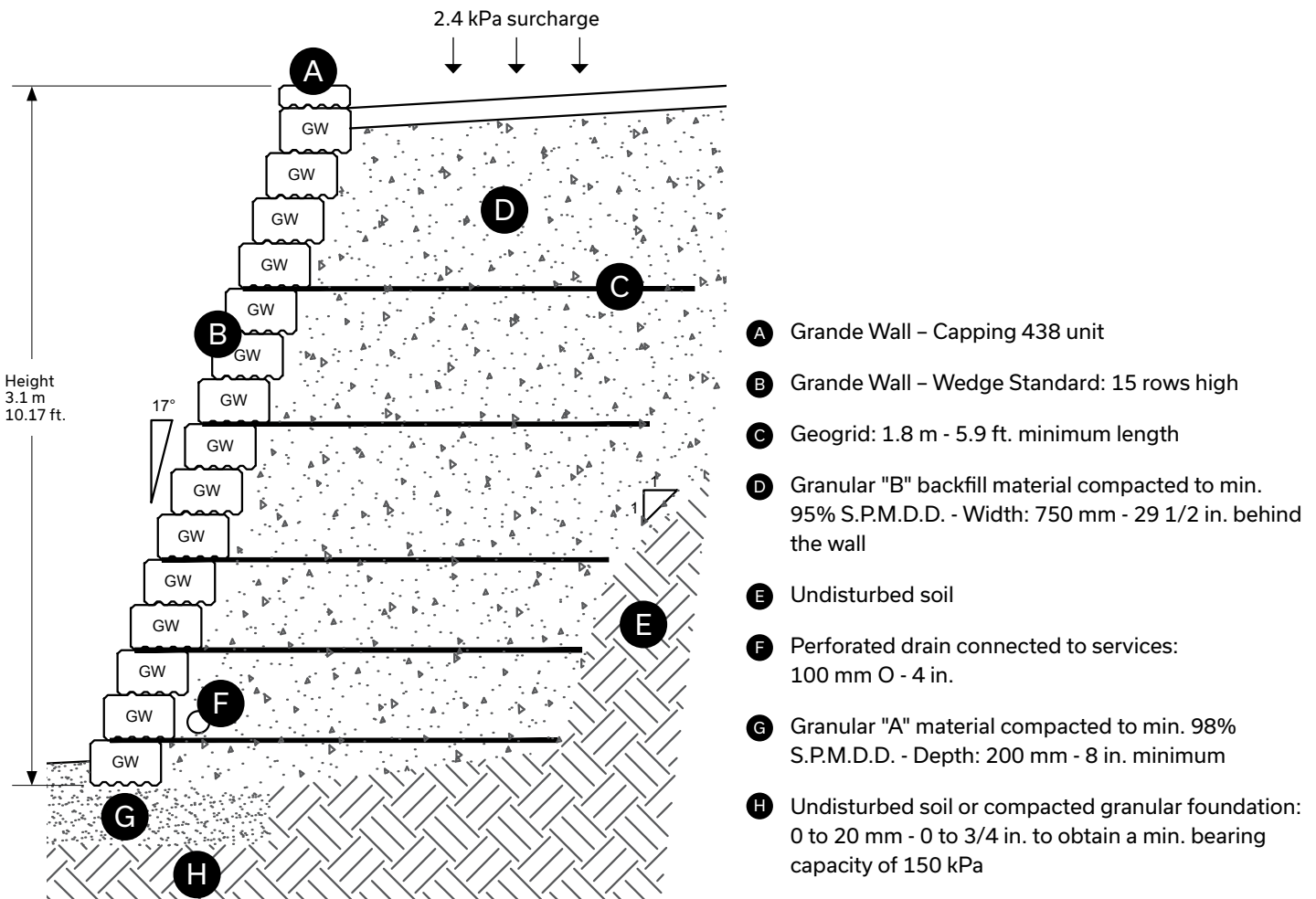

Grande Wedge Wall units are required to create curves with Grande Wall. Permacon is able to provide you with a customized standard cut. For more information, please contact your Permacon representative or send an inquiry directly to our website.

Maximum gravity wall heights assume no slopes or surcharge behind the wall and that the wall retains sand or gravel ($\phi = 34$ degrees, $\gamma = 21 \text{ kN/m}^3$)

GRANDE WALL - INSTALLATION

CROSS-SECTION - GRANDE WALL STRAIGHT REINFORCED 6 ROWS

Grande Wall 6 rows high (1.2 m or 3.9 ft.), including capping

- > Straight
- > Reinforced with geogrid. Recommended geogrid: Miragrid 3XT
- > With 2.4 kPa surcharge
- > No slope behind the wall

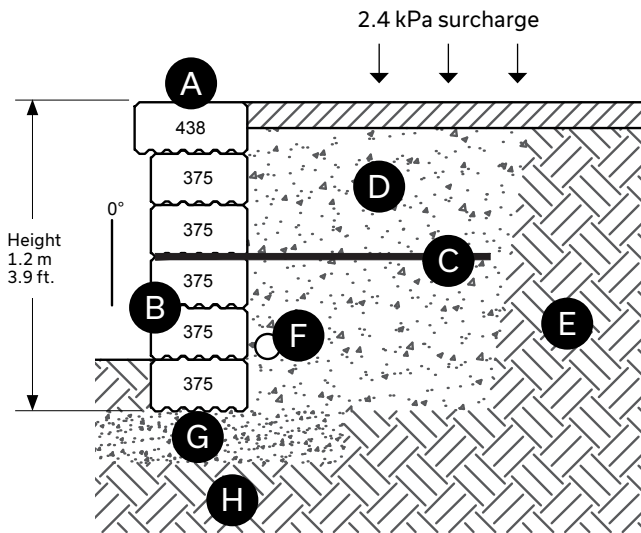

- Ⓐ Grande Wall – Capping 438 unit
- Ⓑ Grande Wall – 375 Standard: 5 rows high
- Ⓒ Geogrid: 1.3 m - 4.3 ft. minimum length
- Ⓓ Granular "B" backfill material compacted to min. 95% S.P.M.D.D. Width: 375 mm - 14 3/4 in. behind the wall
- Ⓔ Undisturbed soil
- Ⓕ Perforated drain connected to services: 100 mm Ø - 4 in.
- Ⓖ Granular "A" material compacted to min. 98% S.P.M.D.D. Depth: 200 mm - 8 in. minimum
- Ⓗ Undisturbed soil or compacted granular foundation: 0 to 20 mm - 0 to 3/4 in. to obtain a min. bearing capacity of 150 kPa

Maximum gravity wall heights assume no slopes or surcharge behind the wall and that the wall retains sand or gravel ($\phi = 34$ degrees, $\gamma = 21 \text{ kN/m}^3$)

GRANDE WALL - INSTALLATION

CROSS-SECTION - GRANDE WALL STRAIGHT REINFORCED 12 ROWS

Grande Wall 12 rows high (2.4 m or 7.9 ft.), including capping

- > Straight
- > Reinforced with geogrid. Recommended geogrid: Miragrid 3XT
- > With 2.4 kPa surcharge
- > No slope behind the wall

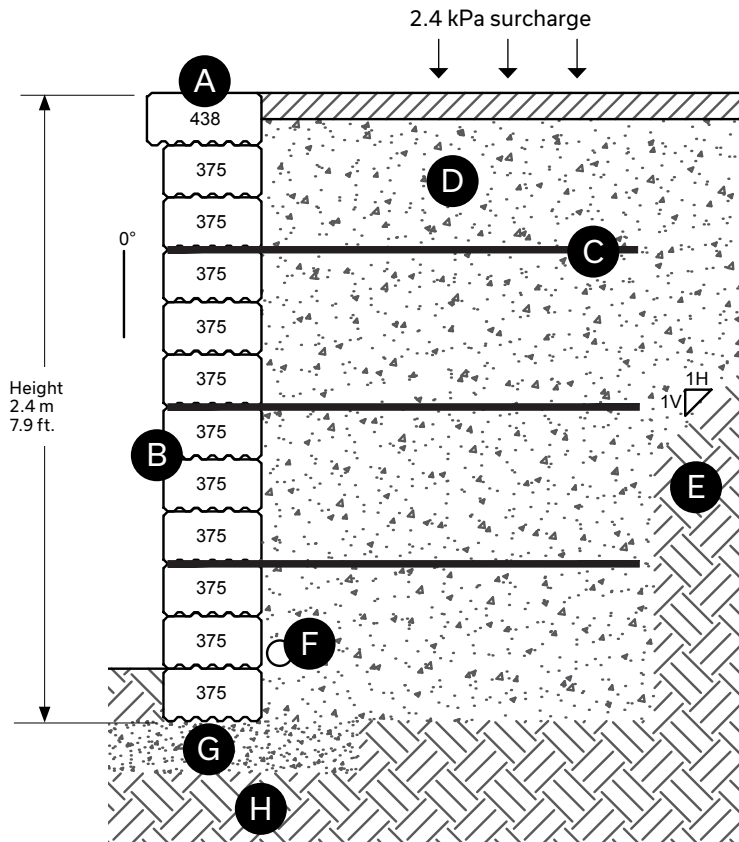

- A** Grande Wall – Capping 438 unit
- B** Grande Wall – 375 Standard: 11 rows high
- C** Geogrid: 1.8 m - 5.9 ft. minimum length
- D** Granular "B" backfill material compacted to min. 95% S.P.M.D.D. - Width: 375 mm - 14 3/4 in. behind the wall
- E** Undisturbed soil
- F** Perforated drain connected to services: 100 mm Ø - 4 in.
- G** Granular "A" material compacted to min. 98% S.P.M.D.D. - Depth: 200 mm - 8 in. minimum
- H** Undisturbed soil or compacted granular foundation: 0 to 20 mm - 0 to 3/4 in. to obtain a min. bearing capacity of 150 kPa

Maximum gravity wall heights assume no slopes or surcharge behind the wall and that the wall retains sand or gravel ($\phi = 34$ degrees, $\gamma = 21 \text{ kN/m}^3$)

GRANDE WALL - INSTALLATION

CROSS-SECTION - GRANDE WALL STRAIGHT REINFORCED 15 ROWS

Grande Wall 15 rows high (3 m or 9.8 ft.), including capping

- > Straight
- > Reinforced with geogrid. Recommended geogrid: Miragrid 3XT
- > With 2.4 kPa surcharge
- > No slope behind the wall

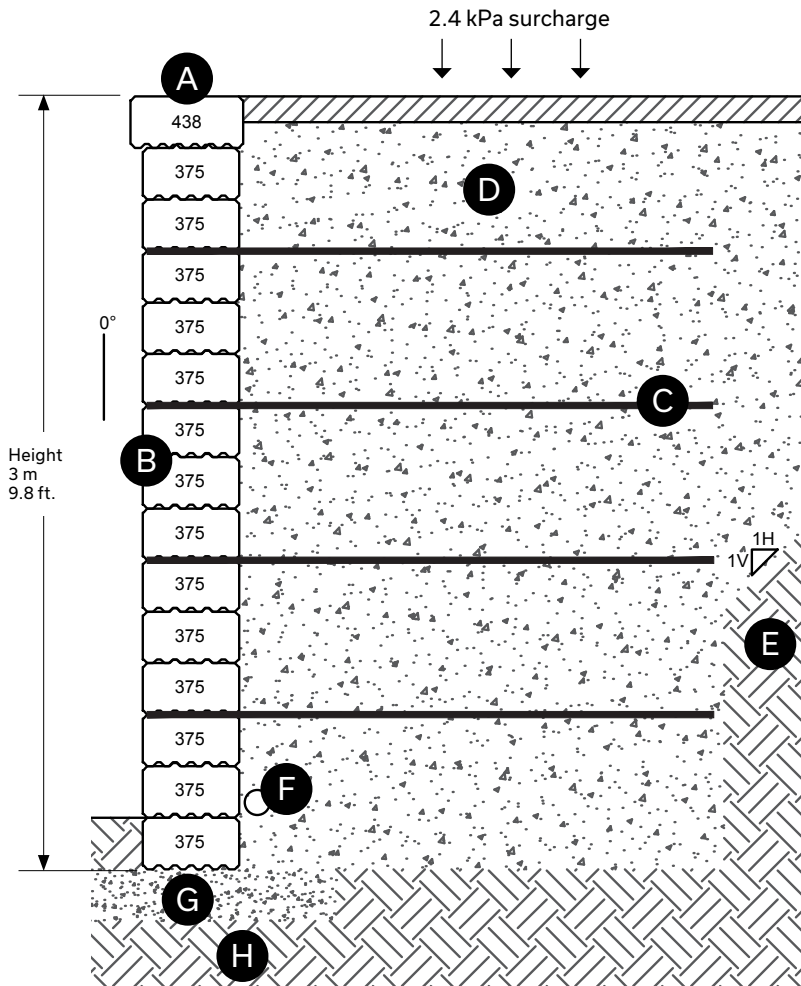

- A** Grande Wall – Capping 438 unit
- B** Grande Wall – 375 Standard: 14 rows high
- C** Geogrid: 2.2 m - 7.2 ft. minimum length
- D** Granular "B" backfill material compacted to min. 95% S.P.M.D.D. - Width: 375 mm - 14 3/4 in. behind the wall
- E** Undisturbed soil
- F** Perforated drain connected to services: 100 mm O - 4 in.
- G** Granular "A" material compacted to min. 98% S.P.M.D.D. - Depth: 200 mm - 8 in. minimum
- H** Undisturbed soil or compacted granular foundation: 0 to 20 mm - 0 to 3/4 in. to obtain a min. bearing capacity of 150 kPa

Maximum gravity wall heights assume no slopes or surcharge behind the wall and that the wall retains sand or gravel ($\phi = 34$ degrees, $\gamma = 21 \text{ kN/m}^3$)

GRANDE WALL - INSTALLATION

CROSS-SECTION - GRANDE WEDGE WALL STRAIGHT REINFORCED 8 ROWS

Grande Wedge Wall 8 rows high (1.3 m or 4.27 ft.), including capping

- > Straight
- > Reinforced with geogrid. Recommended geogrid: Miragrid 3XT
- > With 2.4 kPa surcharge
- > No slope behind the wall
- > Fill the cavities of the Grande Wedge units with clean stone

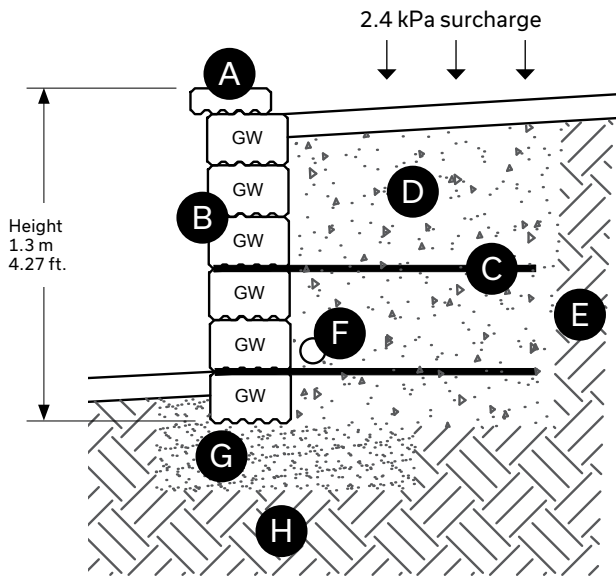

- Ⓐ Grande Wall - Capping 438 unit
- Ⓑ Grande Wall - Wedge Standard: 7 rows high
- Ⓒ Geogrid: 1.3 m - 4.3 ft. minimum length
- Ⓓ Granular "B" backfill material compacted to min. 95% S.P.M.D.D. Width: 750 mm - 29 1/2 in. behind the wall
- Ⓔ Undisturbed soil
- Ⓕ Perforated drain connected to services: 100 mm Ø - 4 in.
- Ⓖ Granular "A" material compacted to min. 98% S.P.M.D.D. Depth: 200 mm - 8 in. minimum
- Ⓗ Undisturbed soil or compacted granular foundation: 0 to 20 mm - 0 to 3/4 in. to obtain a min. bearing capacity of 150 kPa

Grande Wedge Wall units are required to create curves with Grande Wall. Permacon is able to provide you with a customized standard cut. For more information, please contact your Permacon representative or send an inquiry directly to our website.

Maximum gravity wall heights assume no slopes or surcharge behind the wall and that the wall retains sand or gravel ($\phi = 34$ degrees, $\gamma = 21 \text{ kN/m}^3$)

GRANDE WALL - INSTALLATION

CROSS-SECTION - GRANDE WEDGE WALL STRAIGHT REINFORCED 12 ROWS

Grande Wedge Wall 12 rows high (2.3 m or 7.55 ft.), including capping

- > Straight
- > Reinforced with geogrid. Recommended geogrid: Miragrid 3XT
- > With 2.4 kPa surcharge
- > No slope behind the wall
- > Fill the cavities of the Grande Wedge units with clean stone

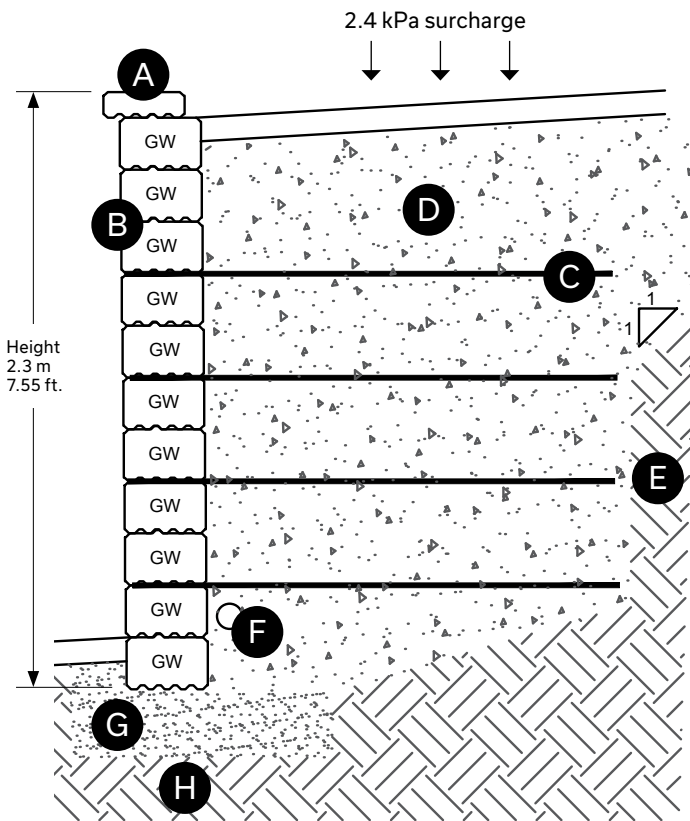

- A Grande Wall - Capping 438 unit
- B Grande Wall - Wedge Standard: 11 rows high
- C Geogrid: 1.6 m - 5.2 ft. minimum length
- D Granular "B" backfill material compacted to min. 95% S.P.M.D.D. - Width: 750 mm - 29 1/2 in. behind the wall
- E Undisturbed soil
- F Perforated drain connected to services: 100 mm Ø - 4 in.
- G Granular "A" material compacted to min. 98% S.P.M.D.D. Depth: 200 mm - 8 in. minimum
- H Undisturbed soil or compacted granular foundation: 0 to 20 mm - 0 to 3/4 in. to obtain a min. bearing capacity of 150 kPa

Grande Wedge Wall units are required to create curves with Grande Wall. Permacon is able to provide you with a customized standard cut. For more information, please contact your Permacon representative or send an inquiry directly to our website.

Maximum gravity wall heights assume no slopes or surcharge behind the wall and that the wall retains sand or gravel ($\phi = 34$ degrees, $\gamma = 21 \text{ kN/m}^3$)

GRANDE WALL - INSTALLATION

CROSS-SECTION - GRANDE WEDGE WALL STRAIGHT REINFORCED 15 ROWS

Grande Wedge Wall 15 rows high (2.9 m or 9.51 ft.), including capping

- > Straight
- > Reinforced with geogrid. Recommended geogrid: Miragrid 3XT
- > With 2.4 kPa surcharge
- > No slope behind the wall
- > Fill the cavities of the Grande Wedge units with clean stone

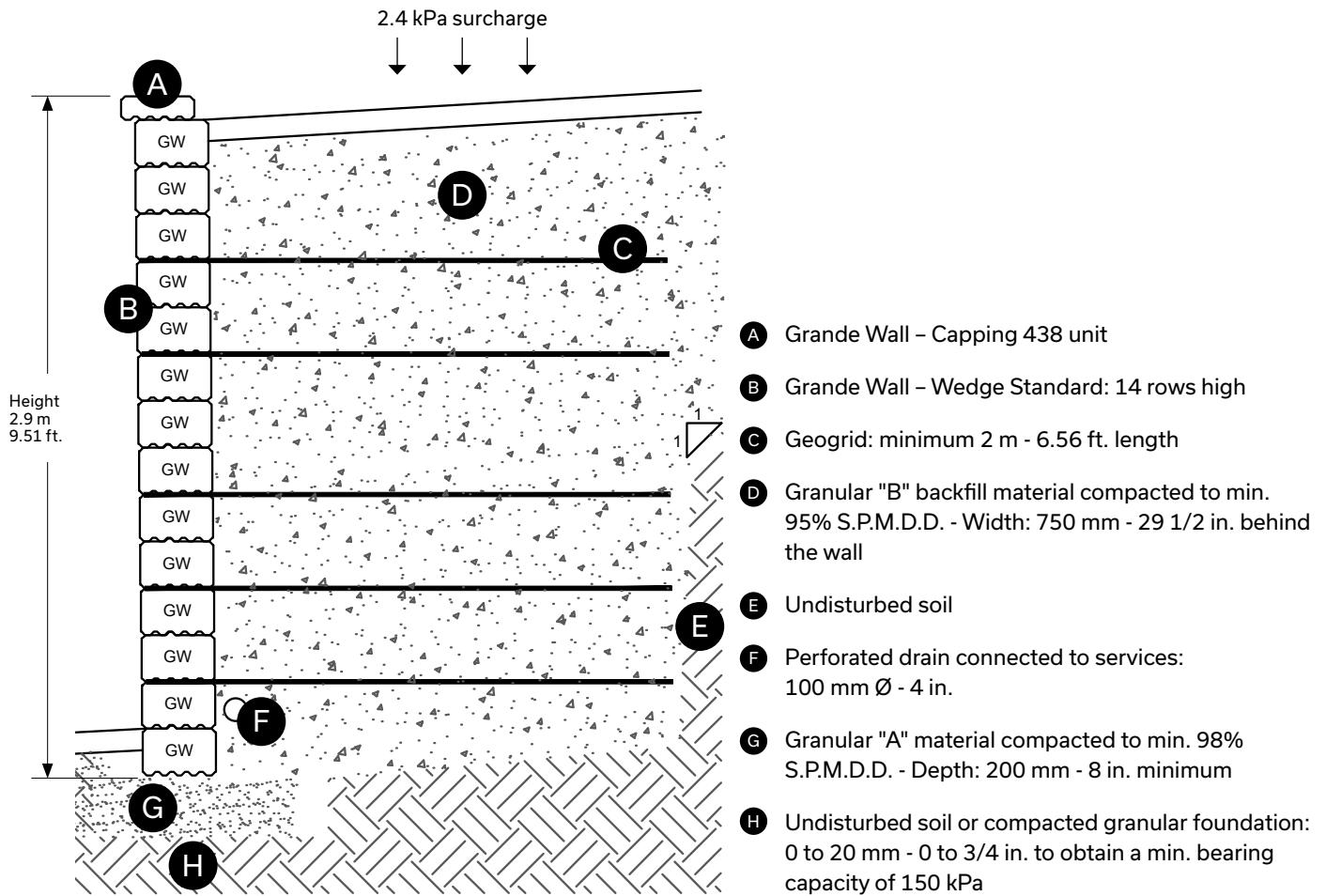

Grande Wedge Wall units are required to create curves with Grande Wall. Permacon is able to provide you with a customized standard cut. For more information, please contact your Permacon representative or send an inquiry directly to our website.

Maximum gravity wall heights assume no slopes or surcharge behind the wall and that the wall retains sand or gravel ($\phi = 34$ degrees, $\gamma = 21 \text{ kN/m}^3$)

GRANDE WALL - INSTALLATION

CROSS-SECTION - CREATING GRANDE WALL STEPS

To create steps, follow these instructions:

- > Start with a Grande Wall 375 Standard unit buried in the soil
- > Use Grande Step 175 units
- > Install the units in a way to create a running bond pattern with the steps
- > The stair width varies according to the local building code

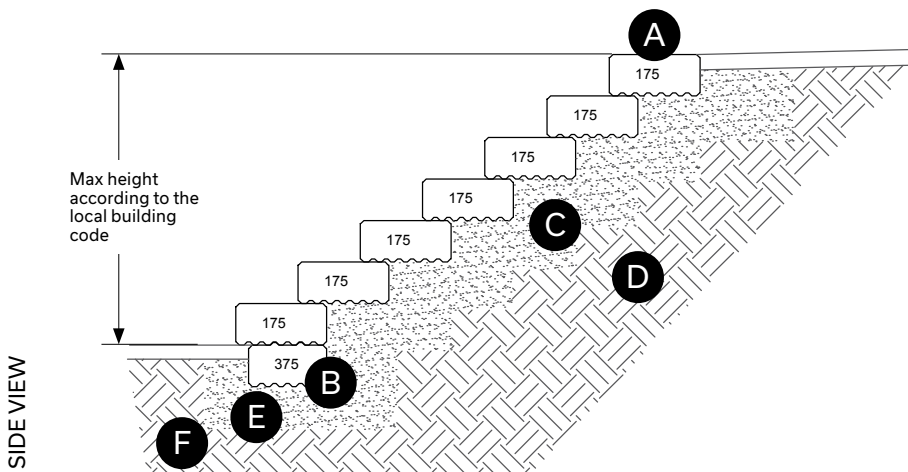
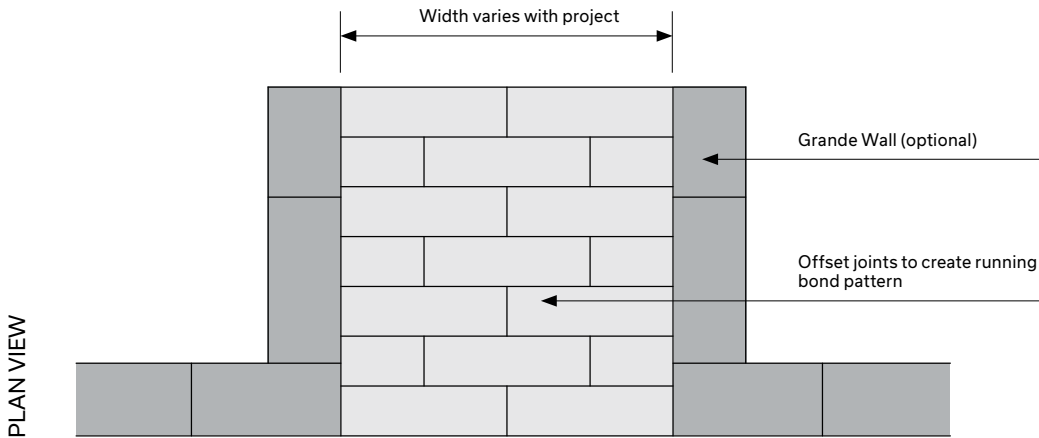

- Ⓐ Grande Wall – Step 175
- Ⓑ Grande Wall – 375 Standard buried in the soil
- Ⓒ Granular "B" backfill material compacted to min. 95% S.P.M.D.D.
- Ⓓ Undisturbed soil
- Ⓔ Granular "A" material compacted to min. 98% S.P.M.D.D.
- Ⓕ Undisturbed soil or compacted granular foundation: 0 to 20 mm - 0 to 3/4 in. to obtain a min. bearing capacity of 150 kPa

Maximum gravity wall heights assume no slopes or surcharge behind the wall and that the wall retains sand or gravel ($\phi = 34$ degrees, $\gamma = 21 \text{ kN/m}^3$)

GRANDE WALL - INSTALLATION

CROSS-SECTION - ADDITION OF A FENCE OR RAILING

GRANDE WALL FENCE

To build a fence using Grande Wall units, follow these instructions:

- > Use fence posts with a diameter of maximum 75 mm - 3 in.
- > Fill the core holes in Grande Wall, drilled to put in the fence, with non-shrink grout.
- > The fence must be reinforced with geogrid or Grande Wall 750 Standard unit, as shown below
- > When using geogrid, the length of the geogrid should respect the cross-section shown in the guide, according to the wall height. Recommended geogrid: Miragrid 3XT
- > The depth of the posts core varies according to the fence used. Contact your Permacon representative for more information.

Install the fence or railing at a distance of at least 125 mm - 5 in. from Grande Wall units edge

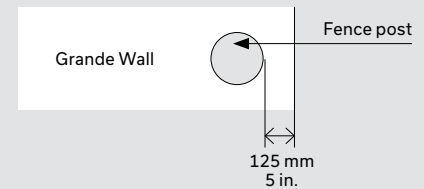

Grande Wall fence reinforced with geogrid

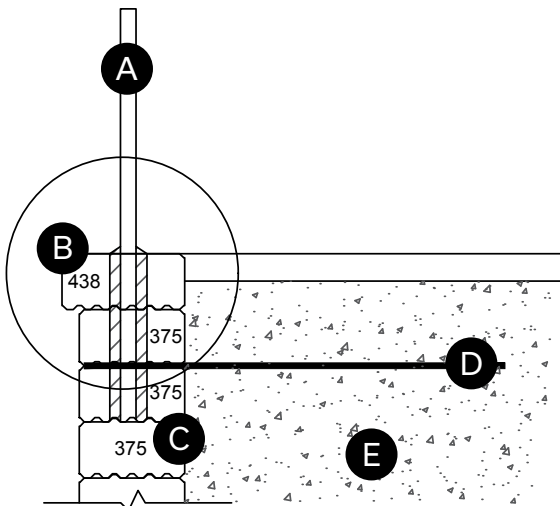

- Ⓐ Steel handrail or chain-link fence: posts core drilled in Grande Wall units (variable depth) with non-shrink grout.
Posts diameter: 75 mm - 3 in. maximum
Distance between the post holes and the edge of Grande Wall units: 125 mm - 5 in.
- Ⓑ Grande Wall - Capping 438
- Ⓒ Grande Wall - Standard 375
- Ⓓ Geogrid
- Ⓔ Granular "B" backfill material compacted to minimum 95% S.S.P.M.D.

Grande Wall fence reinforced with 750 Standard unit

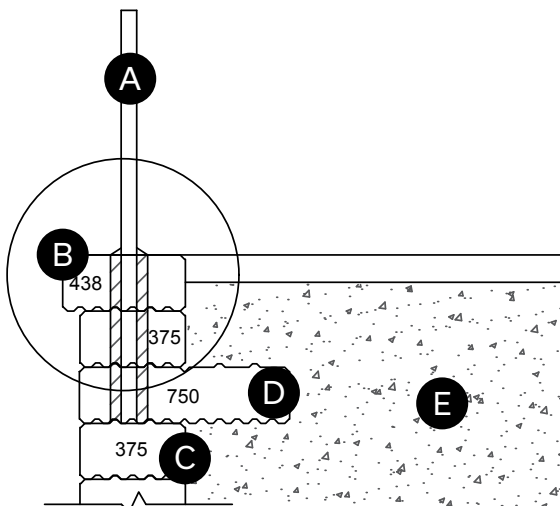

- Ⓐ Steel handrail or chain-link fence: posts core drilled in Grande Wall units (variable depth) with non-shrink grout.
Posts diameter: 75 mm - 3 in. maximum
Distance between the post holes and the edge of Grande Wall units: 125 mm - 5 in.
- Ⓑ Grande Wall - Capping 438
- Ⓒ Grande Wall - Standard 375
- Ⓓ Grande Wall - Standard 750
- Ⓔ Granular "B" backfill material compacted to minimum 95% S.S.P.M.D.

GRANDE WALL - INSTALLATION

CROSS-SECTION - ADDITION OF A FENCE OR RAILING (CONT'D)

FENCE BEHIND GRANDE WALL

To build a fence behind the Grande Wall units, follow these instructions:

- > Install the fence or railing in a sonotube of minimum 1.2 m - 3.9 ft. in depth
- > The wall and fence must be reinforced with a geogrid. The length of the geogrid should respect the cross-section shown in the guide, according to the wall height. Recommended geogrid: Miragrid 3XT

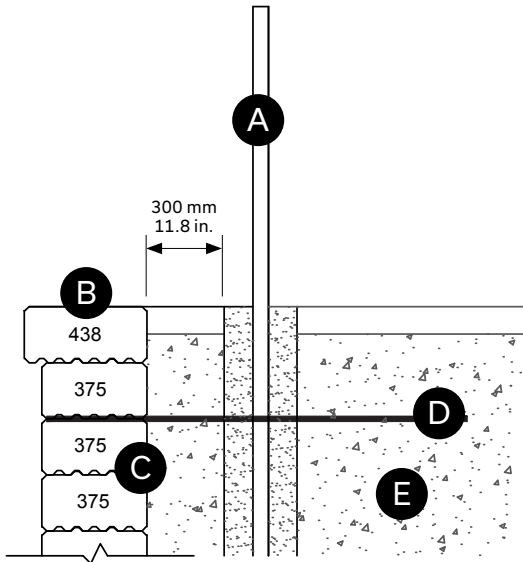

- Ⓐ Handrail or fence cast in sonotube behind the Grande Wall
Distance between the sonotube the edge of Grande Wall units:
300 mm - 11.8 in.
Sonotube depth: 1.2 m - 3.9 ft
- Ⓑ Grande Wall - Capping 438
- Ⓒ Grande Wall - Standard 375
- Ⓓ Geogrid
- Ⓔ Granular "B" backfill material compacted to minimum 95% S.S.P.M.D.

GRANDE WALL - INSTALLATION

CROSS-SECTION - ADDITION OF A FENCE OR RAILING (CONT'D)

FENCE ON TOP OF GRANDE WALL

To build a fence on top of the Grande Wall units, follow these instructions:

- > Use fence posts with a diameter of maximum 75 mm - 3 in.
- > Install the fence or railing at a distance of at least 125 mm- 5 in. from Grande Wall unit edge
- > To strengthen the fence or railing, insert bars coated with epoxy, in the Grande Wall units.
Recommended epoxy: HILTI-RE 500 V3

Fence on top of Grande Wall reinforced with geogrid

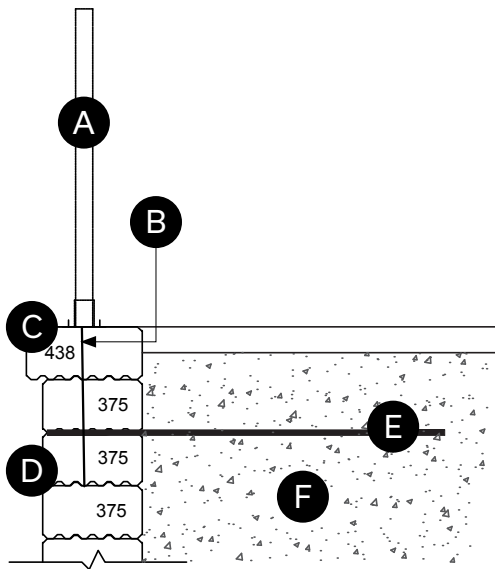

- A** Steel handrail or chain-link fence
- B** Bars coated with epoxy type: HILTI-RE 500 V3 or equivalent
Bars depth: minimum 3 rows of Grande Wall
Diameter of holes in Grande Wall units: 20 mm - 0.8 in.
Distance between the bars holes and the edge of Grande Wall units: 125 mm - 5 in.
- C** Grande Wall – Capping 438
- D** Grande Wall – Standard 375
- E** Geogrid
- F** Granular "B" backfill material compacted to minimum 95% S.S.P.M.D.

Fence on top of Grande Wall reinforced with 750 Standard unit

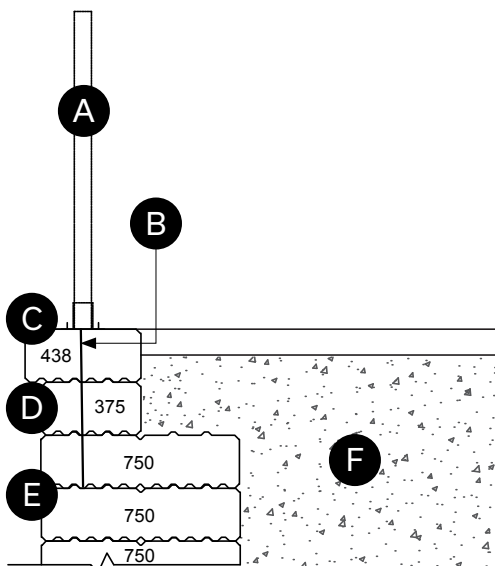

- A** Steel handrail or chain-link fence
- B** Bars coated with epoxy type: HILTI-RE 500 V3 or equivalent
Bars depth: minimum 3 rows of Grande Wall
Diameter of holes in Grande Wall units: 20 mm - 0.8 in.
Distance between the bars holes and the edge of Grande Wall units: 125 mm - 5 in.
- C** Grande Wall – Capping 438
- D** Grande Wall – Standard 375
- E** Grande Wall – Standard 750
- F** Granular "B" backfill material compacted to minimum 95% S.S.P.M.D.

GRANDE WALL - INSTALLATION

CROSS-SECTION - ADDITION OF A FENCE OR RAILING (CONT'D)

VEHICULAR GUARD BEHIND GRANDE WALL

To build a vehicular guard behind Grande Wall units, follow these instructions:

- > Install the vehicular guard at a distance of at least 300 mm (11.8 in.) from Grande Wall units edge and at a depth of at least 1.2 m - 3.9 ft.
- > The wall and vehicular guard must be reinforced with a geogrid. The length of the geogrid should respect the cross-section shown in the guide, according to the wall height. Recommended geogrid: Miragrid 3XT

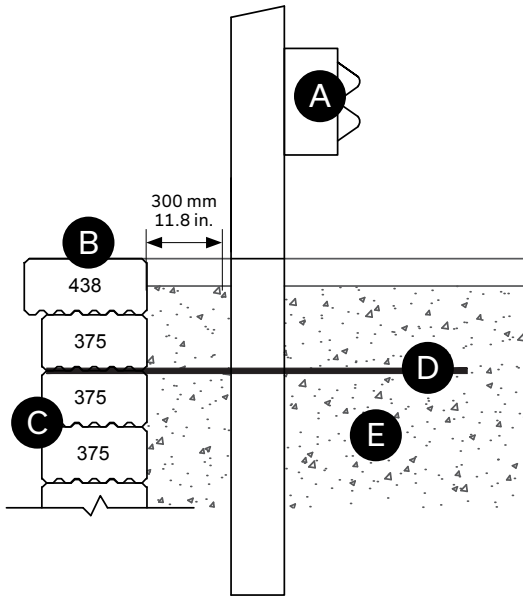

- Ⓐ Vehicular guard
Distance between the guard and the edge of Grande Wall units:
300 mm - 11.8 po
Depth of guard: 1.2 m - 3.9 ft. min.
- Ⓑ Grande Wall – Capping 438
- Ⓒ Grande Wall – Standard 375
- Ⓓ Geogrid
- Ⓔ Granular "B" backfill material compacted to minimum 95% S.S.P.M.D.

CROSS-SECTION - DRAIN

DRAIN OUTLET THROUGH GRANDE WALL

When not connected to services, the drain behind the Grande Wall must go through the Grande Wall units at every 15 m - 49.2 ft., according to these instructions:

- > Install a filter fabric over the drain outlet to prevent migration of granular material through notch
- > There are two ways to create the hole in the Grande Wall:
 - Option 1: Cut the Grande Wall units around the drain outlet **OR**
 - Option 2: Install the Grande Wall units against the drain outlet, which leaves a hole above the drain outlet

Option 1: Grande Wall units cut around the drain outlet

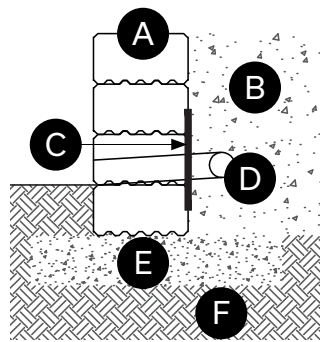
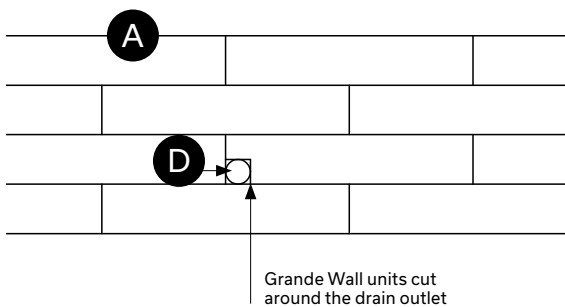

- A** Grande Wall - Standard 375
- B** Granular "B" backfill material compacted to minimum 95% S.S.P.M.D
- C** Filter fabric over the drain outlet to prevent migration of granular material through notch
- D** Perforated drain Ø 100 mm - 4 in with a filter sock at the opening (Grande Wall face)
- E** Granular "A" material compacted to min. 98% S.P.M.D.D.
- F** Undisturbed soil

Option 2: Grande Wall units installed against the drain outlet

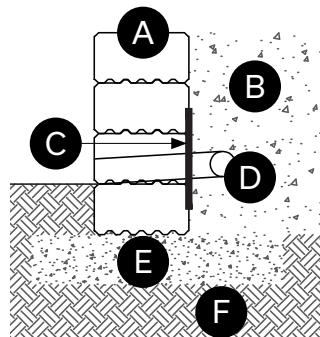
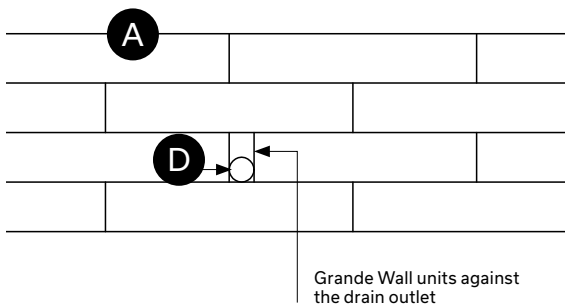

- A** Grande Wall - Standard 375
- B** Granular "B" backfill material compacted to minimum 95% S.S.P.M.D
- C** Filter fabric over the drain outlet to prevent migration of granular material through notch
- D** Perforated drain Ø 100 mm - 4 in with a filter sock at the opening (Grande Wall face)
- E** Granular "A" material compacted to min. 98% S.P.M.D.D.
- F** Undisturbed soil

GRANDE WALL - INSTALLATION

CROSS-SECTION - GRANDE WALL AGAINST A BUILDING

To install the Grande Wall against an existing wall, follow these instructions:

- > Install a filter fabric against the Grande Wall and the existing wall. Fabric length: 0.5 m - 1.7 ft. minimum on each structure - Grande Wall and existing wall. Fabric height: same as Grande Wall

Straight abutment

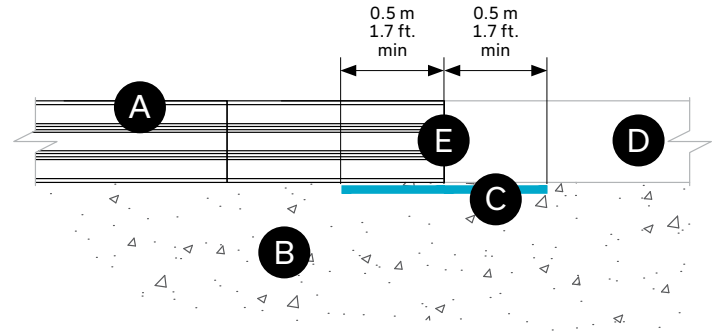
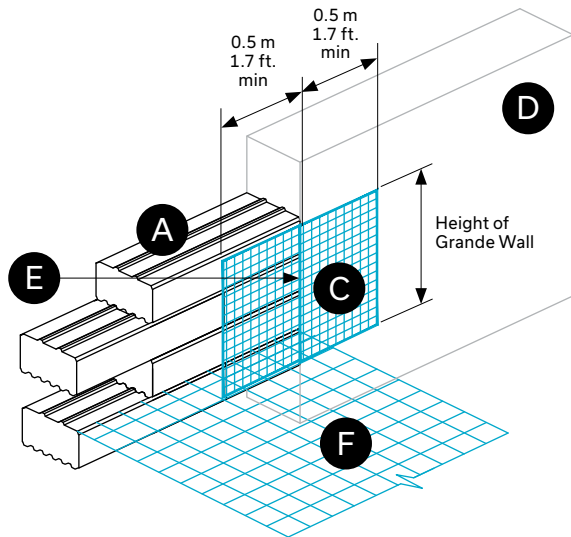

- A** Grande Wall
- B** Granular "B" backfill material compacted to minimum 95% S.S.P.M.D.
- C** Filter fabric
Length: 0.5 m - 1.7 ft. minimum on each structure
Height: same as Grande Wall
- D** Existing wall or building
- E** Grande Wall units cut against the existing building
- F** Geogrid if required

Corner abutment

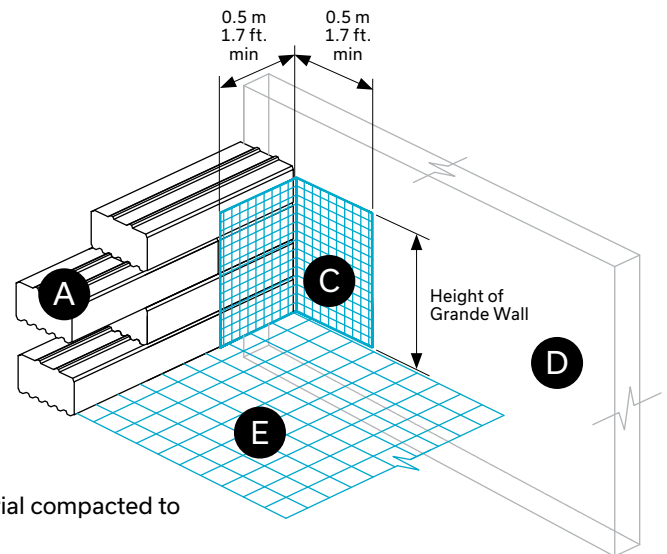
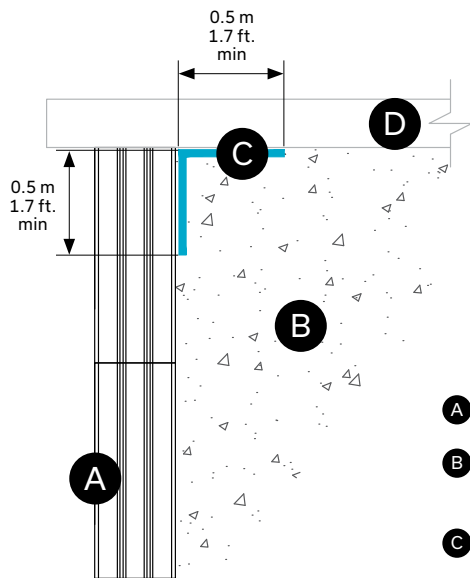

- A** Grande Wall
- B** Granular "B" backfill material compacted to minimum 95% S.S.P.M.D.
- C** Filter fabric
Length: 0.5 m - 1.7 ft. minimum on each structure
Height: same as Grande Wall
- D** Existing wall or building
- E** Geogrid if required

Orion Wall

DESCRIPTION



Build outdoor living elements with ease: flower boxes, privacy walls, flower beds, etc. No hardware nor accessories are required for the installation. With its slender format and smooth texture, Orion Wall will bring elegance and modernity to all your designs. No need to add a capping unit—all Orion wall units have finished corners, faces and tops.

UNIT

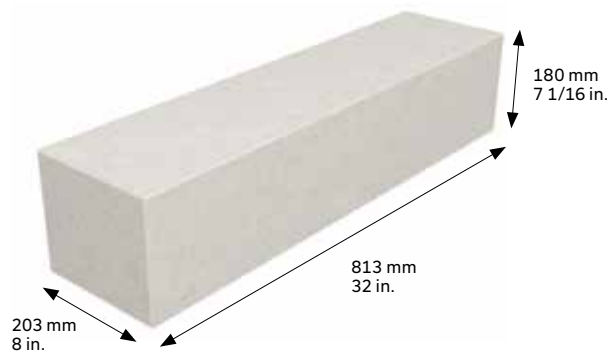

TECHNICAL INFORMATION

	MAX HEIGHT ft.	MAX HEIGHT m.	SETBACK degrees	QUANTITY ft ²	QUANTITY m ²
Setback	—	—	—	—	—
Straight	2.35	0.72	—	0.63	6.83

BASIC PRINCIPLES

Front View

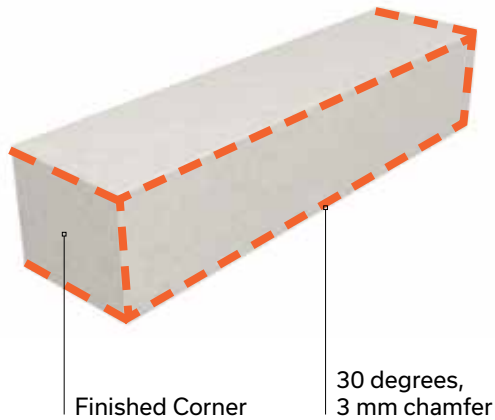

Underside View

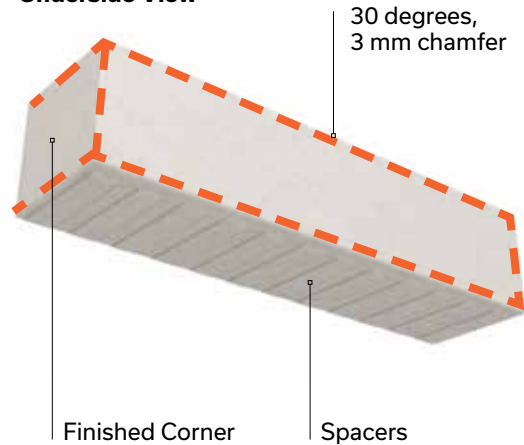

TYPICAL ROW

CAUTION !
 Orion units must be turned on their side once removed from the skid. The spacers should face the ground. The face with the chamfers goes on the outside of the wall.

LAYING PATTERN

RUNNING BOND PATTERN

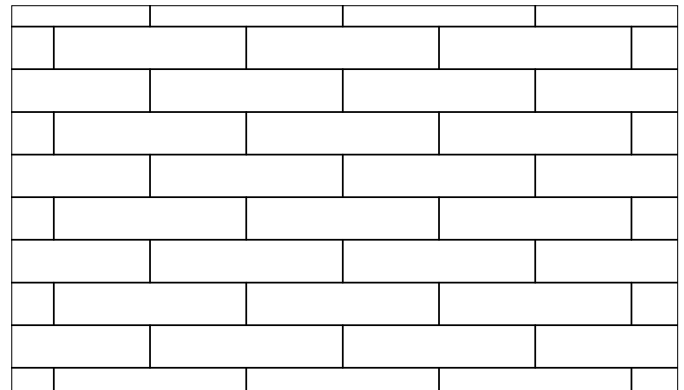

CREATING OUTER AND INNER CORNERS

It is recommended to always begin the construction of a retaining wall with a corner in order to avoid cuts and an alignment of vertical joints from one row to another. Orion units have to be glued together with a Techniseal concrete adhesive.



ORION WALL

CROSS-SECTION – VERTICAL WALL

Orion Wall installed in a vertical application can go up to 4 rows (total height of 720 mm or 28 1/4 in).

- > Use Techniseal concrete adhesive between rows of Orion Wall
- > Orion Wall can be used with or without capping over the last row. If a capping unit is installed, simply glue it with concrete adhesive.

No accessory required for the Orion Wall.

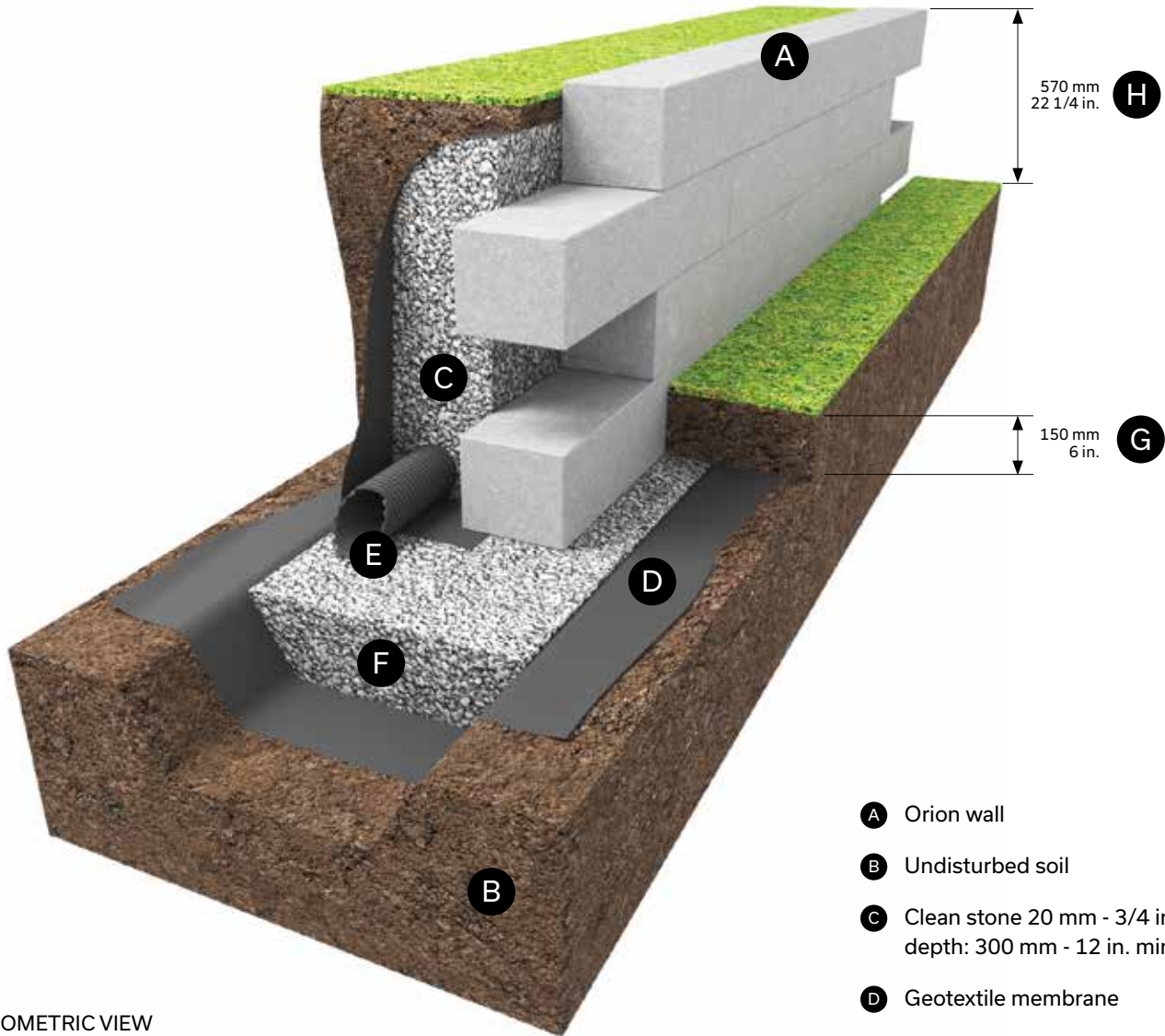

ISOMETRIC VIEW

- Ⓐ Orion wall
- Ⓑ Undisturbed soil
- Ⓒ Clean stone 20 mm - 3/4 in. - depth: 300 mm - 12 in. minimum
- Ⓓ Geotextile membrane
- Ⓔ Perforated drain connected to services: 100 mm Ø - 4 in.
- Ⓕ Compacted granular foundation: 0 to 20 mm - 0 to 3/4 in. Depth: 300 mm - 12 in. minimum
- Ⓖ Minimum buried depth 150 mm - 6 in.
- Ⓗ Maximum height without surcharges or slopes behind the wall, excluding the buried units and capping

Maximum gravity wall heights assume no slopes or surcharge behind the wall and that the wall retains sand or gravel ($\phi = 34$ degrees, $\gamma = 19$ kN/m³)

CROSS-SECTION – VERTICAL WALL

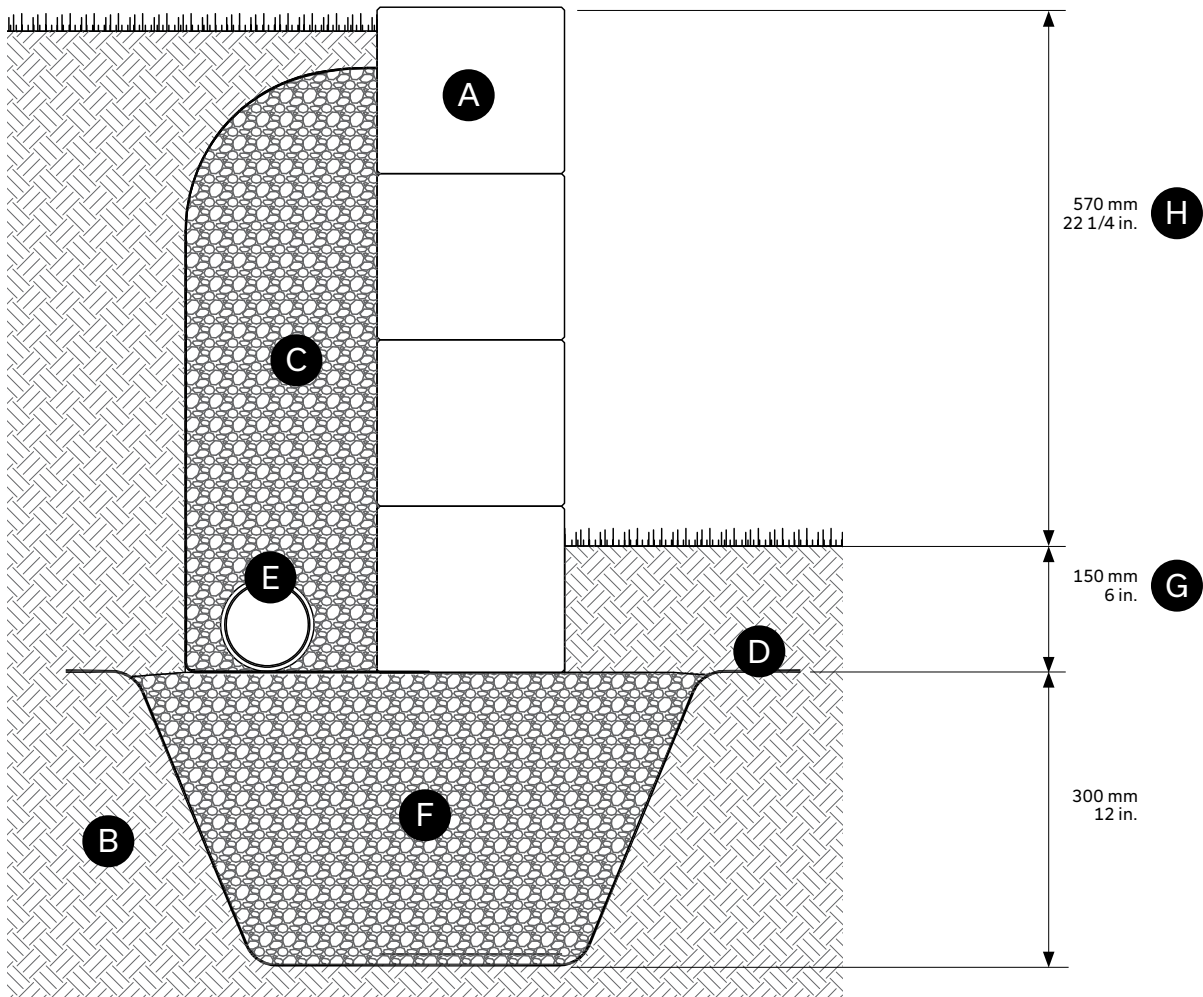

- Ⓐ Orion wall
- Ⓑ Undisturbed soil
- Ⓒ Clean stone 20 mm - 3/4 in.
Depth: 300 mm - 12 in. minimum
- Ⓓ Geotextile membrane
- Ⓔ Perforated drain connected to services:
100 mm Ø - 4 in.
- Ⓕ Compacted granular foundation: 0 to 20 mm - 0 to 3/4 in.
Depth: 300 mm - 12 in. minimum
- Ⓖ Minimum buried depth 150 mm - 6 in.
- Ⓗ Maximum height without surcharges or slopes behind the wall, excluding the buried units and capping

Maximum gravity wall heights assume no slopes or surcharge behind the wall and that the wall retains sand or gravel ($\phi = 34$ degrees, $\gamma = 19$ kN/m³)

ORION WALL

CROSS-SECTION – CREATING ORION WALL STEPS

To create steps, install the Melville 60 step combined with the Orion Wall units used as risers, as detailed below:

> Use Techniseal concrete adhesive to glue the step unit

No accessory required for the Orion Wall.

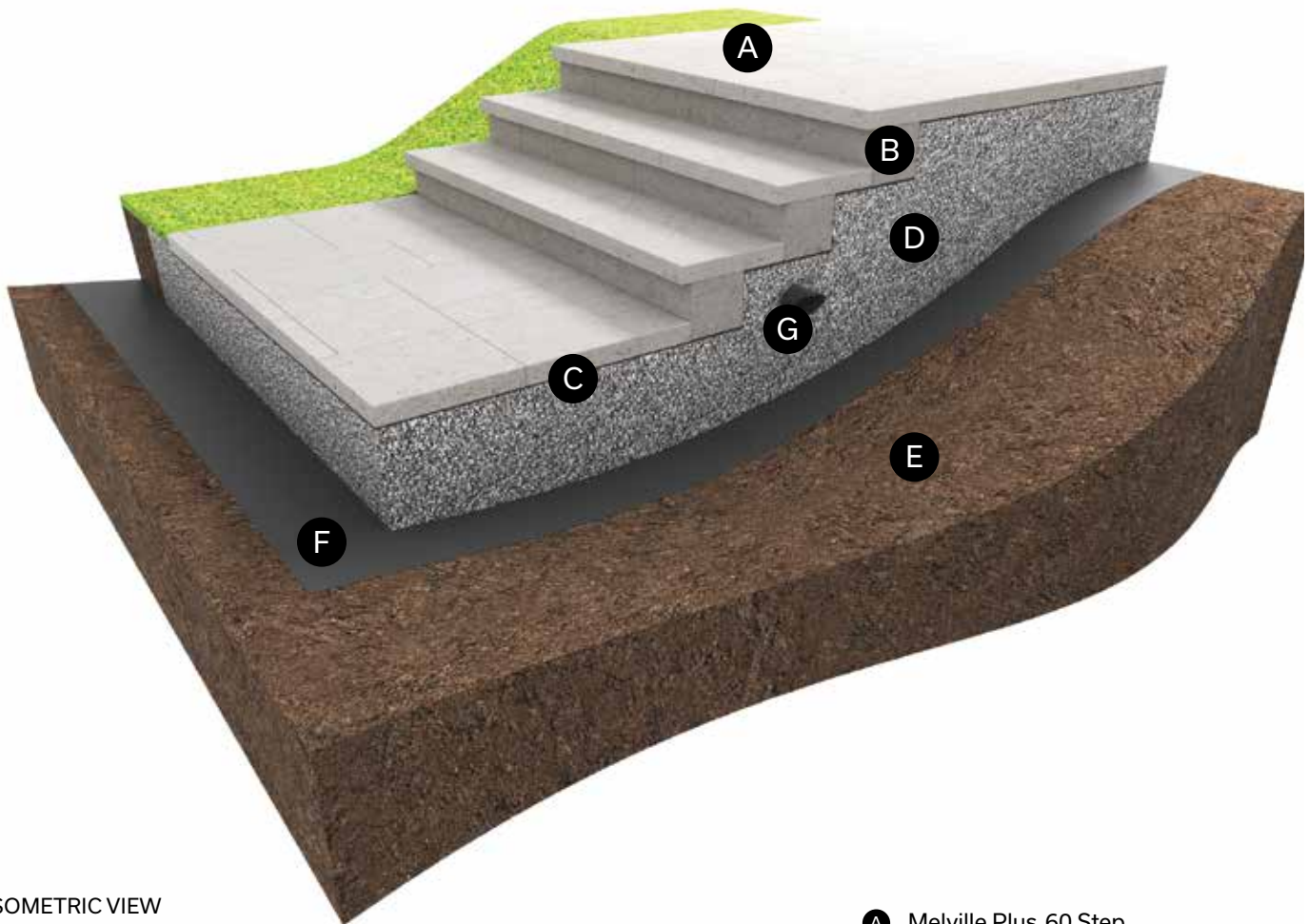

ISOMETRIC VIEW

- Ⓐ Melville Plus 60 Step
- Ⓑ Orion wall
- Ⓒ Laying bed: 25 mm - 1 in.
- Ⓓ Compacted granular foundation:
0 to 20 mm - 0 to 3/4 in.
Depth: 300 mm - 12 in. minimum
- Ⓔ Soil in place
- Ⓕ Geotextile membrane
- Ⓖ Perforated drain connected to services:
100 mm Ø - 4 in.

CROSS-SECTION – CREATING ORION WALL STEPS

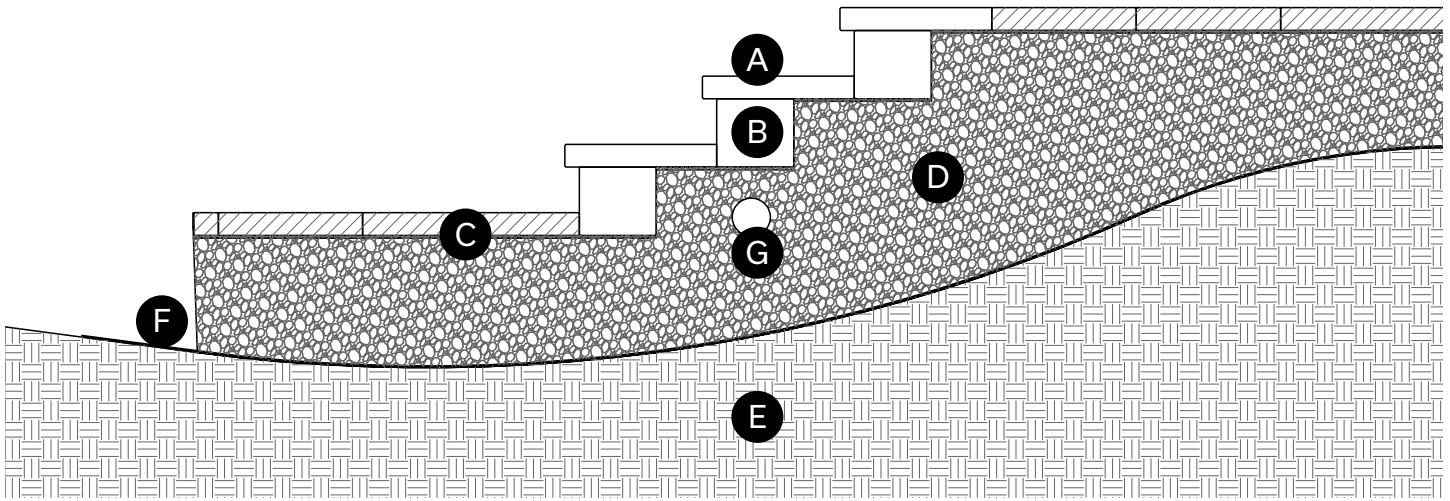

- A Melville Plus 60 Step
- B Orion wall
- C Laying bed: 25 mm - 1 in.
- D Compacted granular foundation:
0 to 20 mm - 0 to 3/4 in.
Depth: 300 mm - 12 in. minimum
- E Soil in place
- F Geotextile membrane
- G Perforated drain connected to services:
100 mm Ø - 4 in.

RB Wall

DESCRIPTION

RB wall comes complete with corner units and several capping options for straight walls.

TIPS: Build vertical walls by knocking off the back half of each of the two ribs on top of the block using a hammer and chisel.

UNITS

STANDARD UNIT

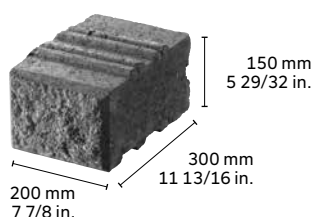

CORNER UNIT

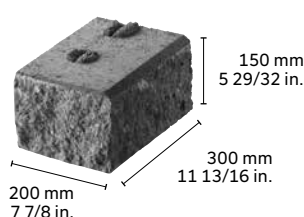

24 IN. CAPPING UNIT

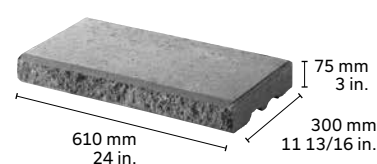

CROSS-SECTION

2 FOOT WALL HEIGHT

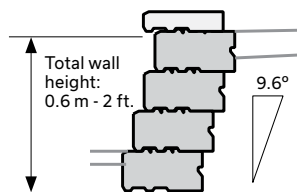

GRAVITY

4 FOOT WALL HEIGHT

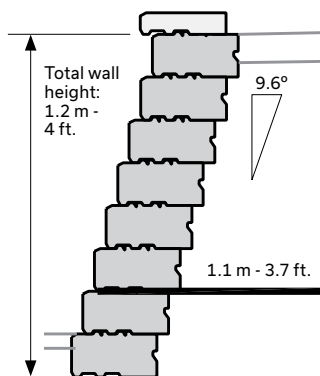

GRID

6 FOOT WALL HEIGHT

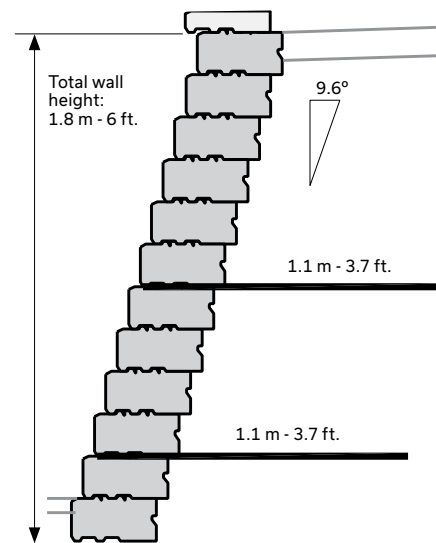

GRID

NOTES: 1 - Sample designs based on 2.4 kPa (50 psf) pedestrian surcharge. Use as preliminary design only when actual soil and surcharge conditions are conservatively represented by the standard engineering. In all cases, designs should be reviewed by a geotechnical engineer to ensure applicability to site. 2 - Designs consider free draining sand and gravel backfill material compacted to 95% SPMD to a minimum depth of 375 mm - 15 in. behind the wall or to full extent of geogrid reinforcement, whichever is greater. Backfill materials to have less than 8% passing through the # 200 sieve. 3 - Designs consider 19 mm - 0 to 3/4 in. well graded, crushed angular granular materials for a minimum depth of 200 mm - 8 in. under the wall compacted to 98% SPMD. Material to have less than 8% passing through the # 200 sieve. 4 - Designs consider minimum bearing capacity in subgrade soil below wall of 150 kPa (3000 psf). 5 - Different batter configurations, surcharge conditions or wall heights require different design configurations. 6 - No provision has been made for overall global stability of the designs. 7 - Minimum 100 mm - 4 in. of product must be buried in all situations. Design may require more depending on soil conditions or toe slope. 8 - Grid lengths are measured from front face of wall. 9 - Geogrid used in designs is Miragrid 2XT or 3XT. 10 - Designs for wall heights, batters and surcharges not represented on these pages can be attained from Permacon. 11 - Refer to standard engineering drawings for further details. 12 - Total wall height for Permacon RB Wall does not include capping unit. 13 - Sample designs are not designed for handrail, guard or fence loading. In these cases, design modifications will be required. 14 - Poor soil conditions and excessive moisture will require drainage and design modifications.

CORNER - SINGLE DEPTH

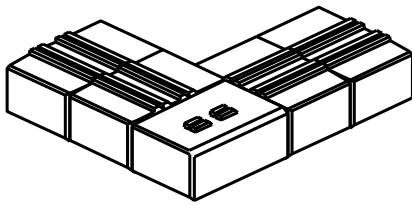

ROW A

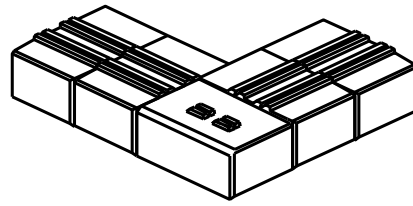

ROW B

STEPS

Risers are built using RB standard units with 24 in. capping unit as treads.

TO CALCULATE PRODUCT REQUIREMENTS:

Standard units = step width x 1.5 x # of risers + step width x 1.5
Capping units = step width ÷ by capping width x 1.5 x # of risers

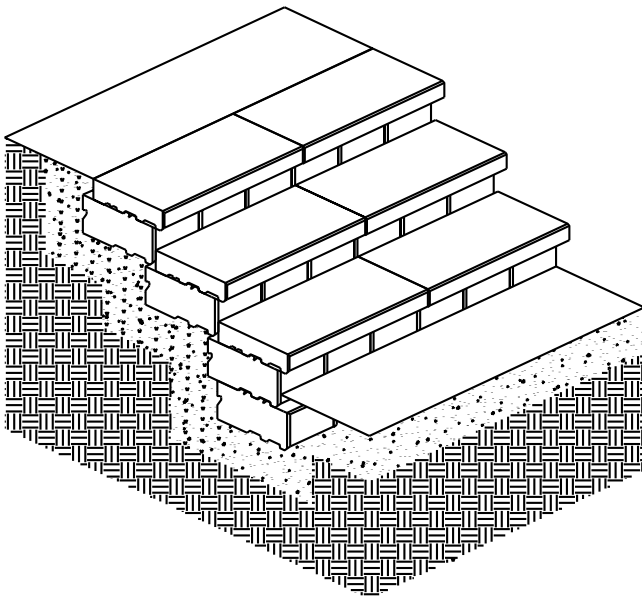

Universal Slope Block Wall

UNITS

UNIVERSAL SLOPE

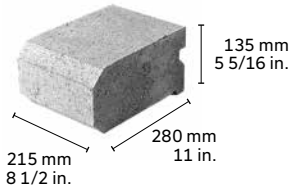

SPLIT-FACE UNIVERSAL SLOPE

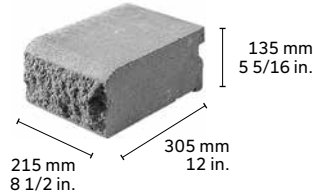

LAYING PATTERN

LINEAR PATTERN

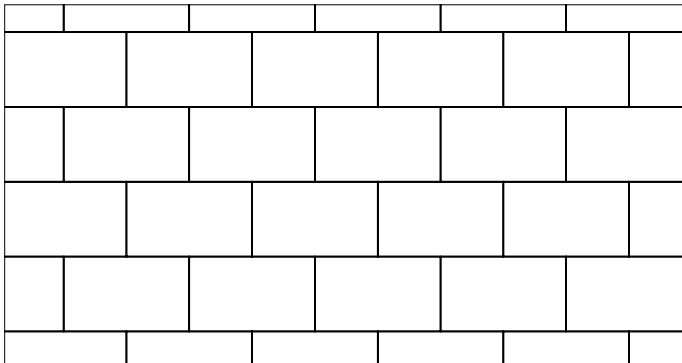

CROSS-SECTION - UNIVERSAL SLOPE AND SPLIT-FACE UNIVERSAL SLOPE BLOCKS

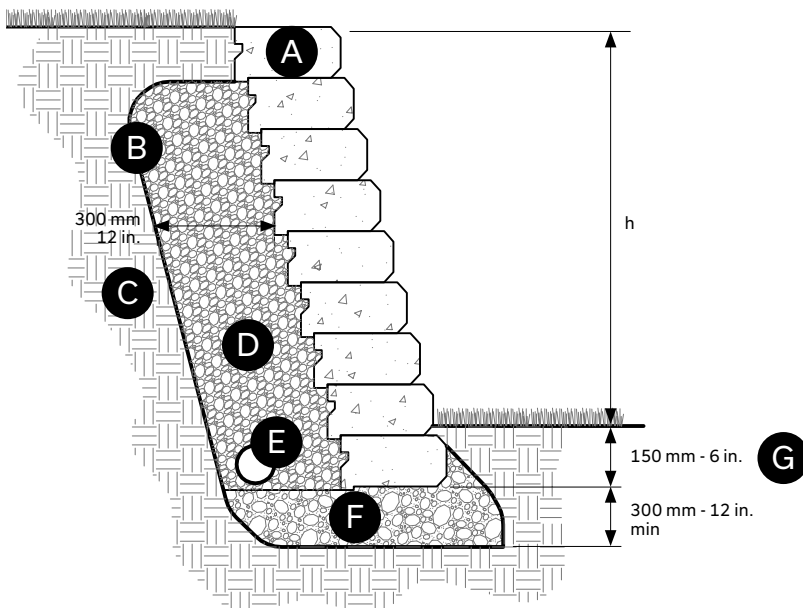

- A** Universal slope block wall unit
- B** Geotextile
- C** Existing soil
- D** Clean stone 20 mm - 3/4 in.
- E** Perforated drain connected to services: 100 mm Ø - 4 in.
- F** Compacted granular foundation: 0 to 20 mm - 0 to 3/4 in.
- G** Minimum buried depth 150 mm - 6 in.

Urbano Wall™

DESCRIPTION



Offering a contemporary look, the Urbano wall is distinguished by its refined, elongated formats and varying lengths. The integrated corner of each wall unit allows you to design a high-quality landscape project. With the Urbano wall, you can also quickly create flowerbeds or firepits. Available in trendy colours, the Urbano wall helps to enhance any landscape design.

ADVANTAGES:

- > Modern and refined finish
- > Quick and easy to install
- > Integrated corner on each unit
- > 120 mm height with multiple lengths for a slim design
- > Available in three trendy colours

UNITS

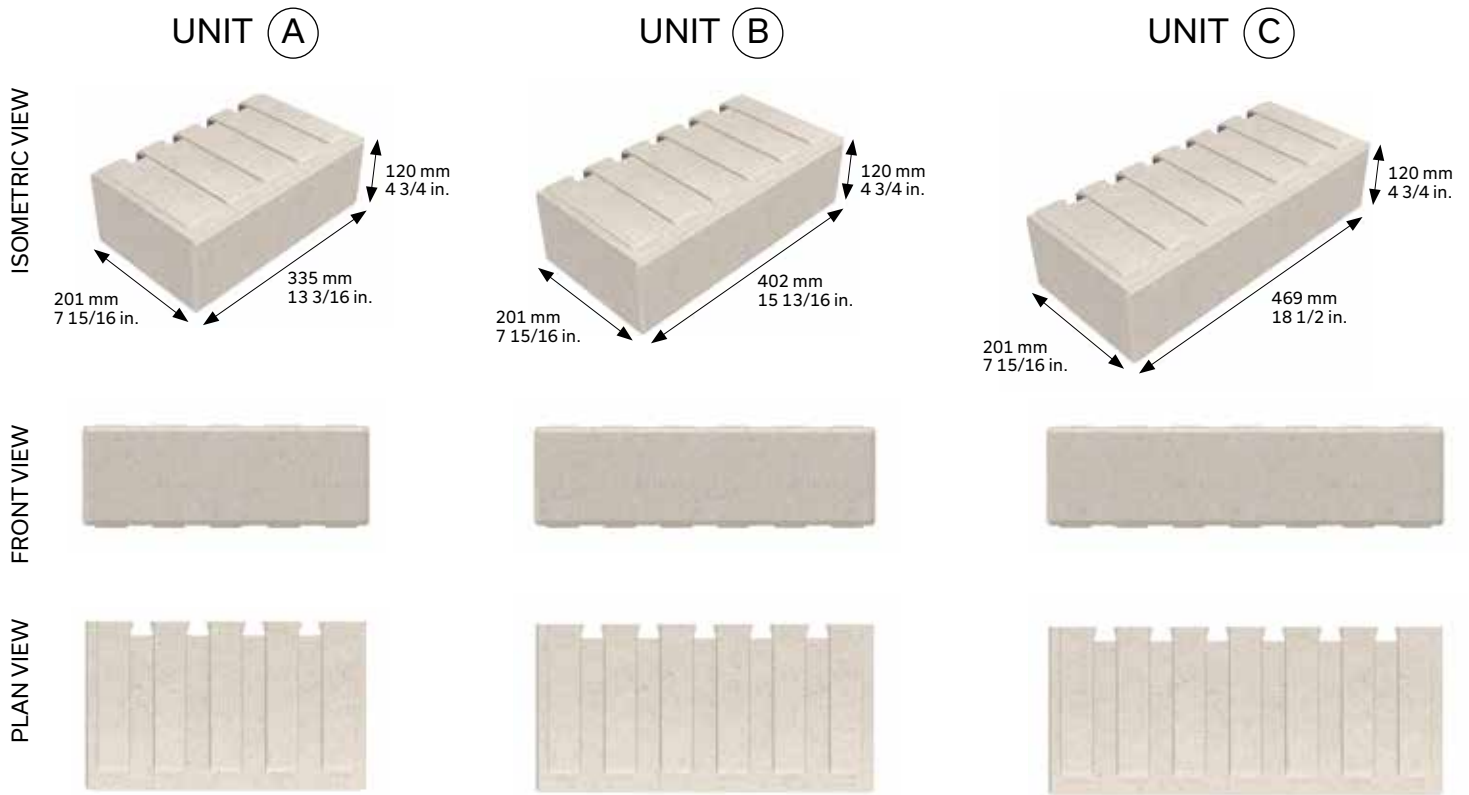

Note that units A, B and C are packaged on the same cube.

LAYING PATTERN

LINEAR PATTERN

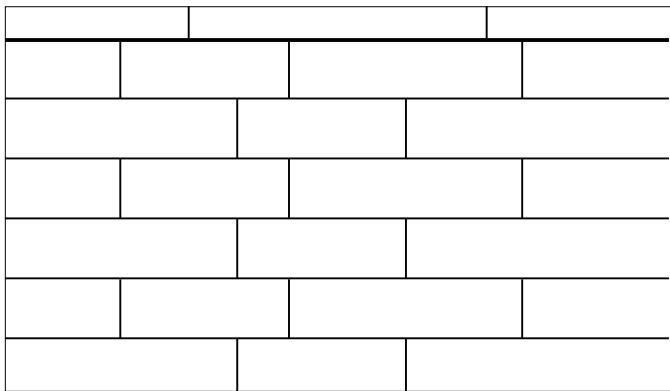

BASIC PRINCIPLES

Universal anchor that fits into the dovetails.
Vertical or setback installation.

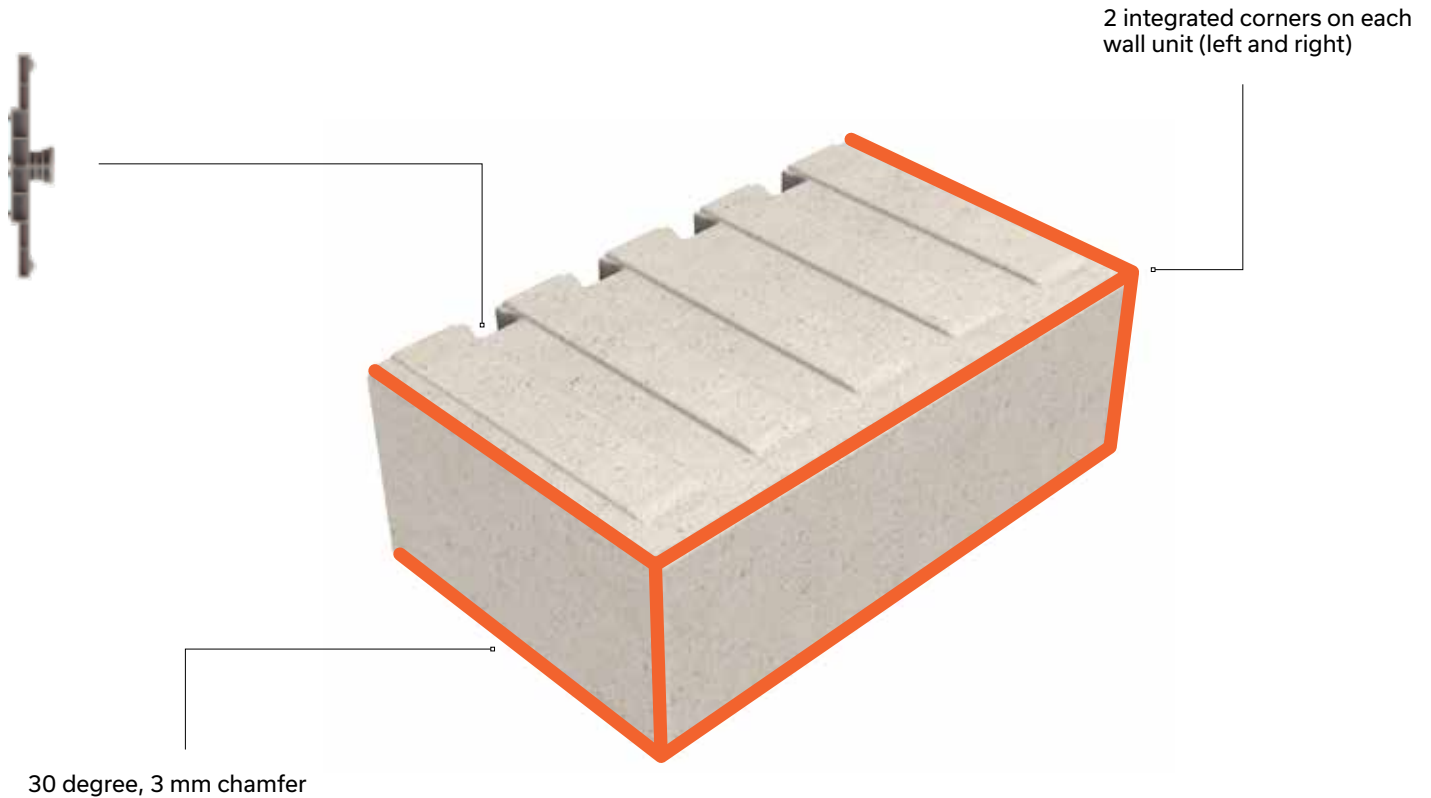

UNIVERSAL ANCHOR

The Urbano wall anchoring system is designed to facilitate the construction of a vertical or 3 degree setback wall. This anchoring system enables the installation and alignment of the wall units. Note that the anchor box is located inside the pallet between the 2 central wooden slats as shown in the image below.



SETBACK WALL

The Urbano wall can be installed either vertically or with a setback using the universal anchor designed specifically for this purpose. This anchor is inserted into one of the grooves located at the back of the units. Anchors must be slid from the top of the grooves until they overlap the wall unit below by a few centimeters. Two universal anchors are generally recommended for each Urbano wall unit. To build a setback wall, the anchor must be placed as shown in the illustration in STEP 1. Once the anchor is in place, simply push the wall unit forward until the anchor locks it in place, creating a setback of approximately 8 mm from the lower unit.

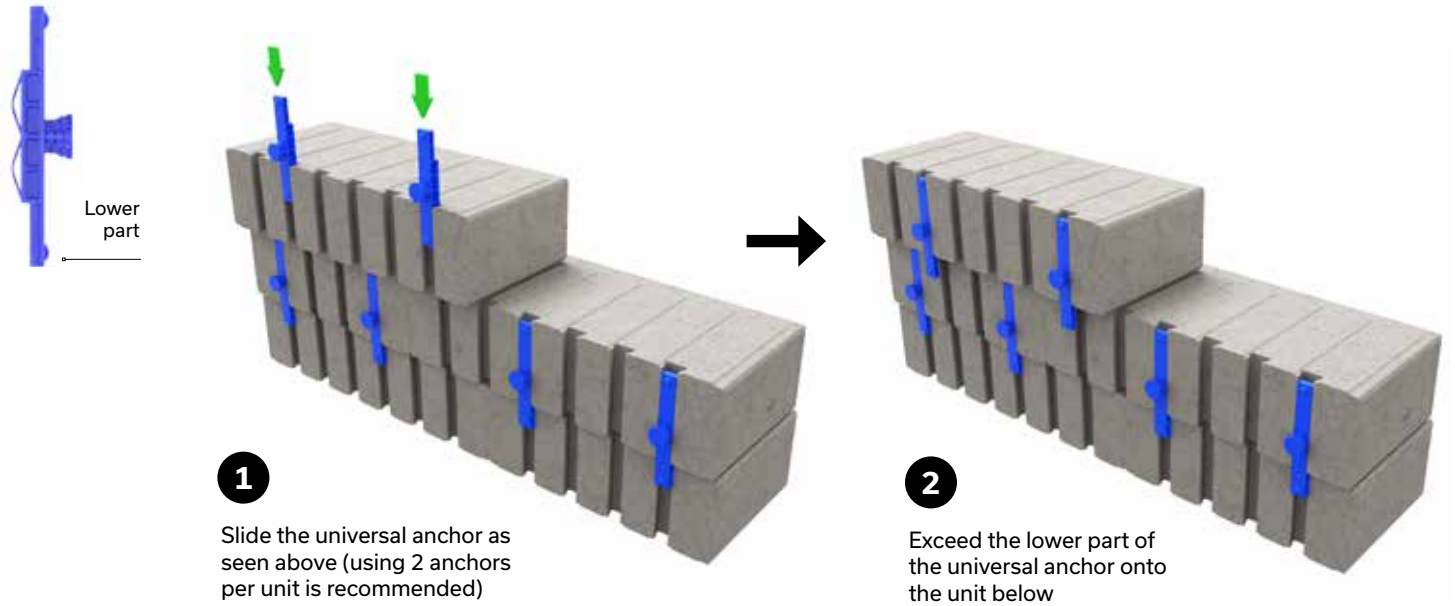

CROSS-SECTION VIEW

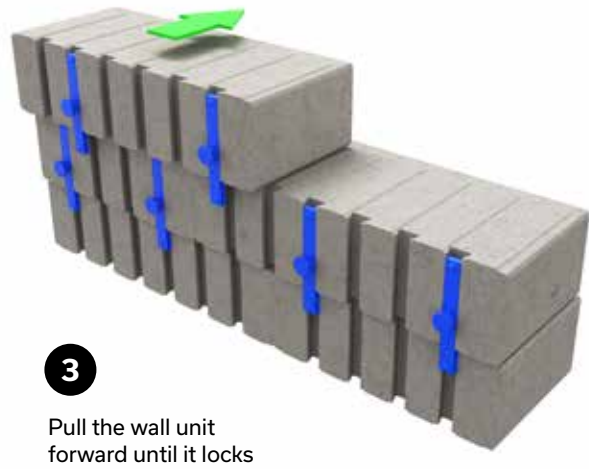

VERTICAL WALL

The vertical wall applies the same principle as the setback wall except that the universal anchor is installed on the opposite side and must be rotated 45 degrees. The Urbano wall unit is then pushed forward until it locks, creating a vertical wall.

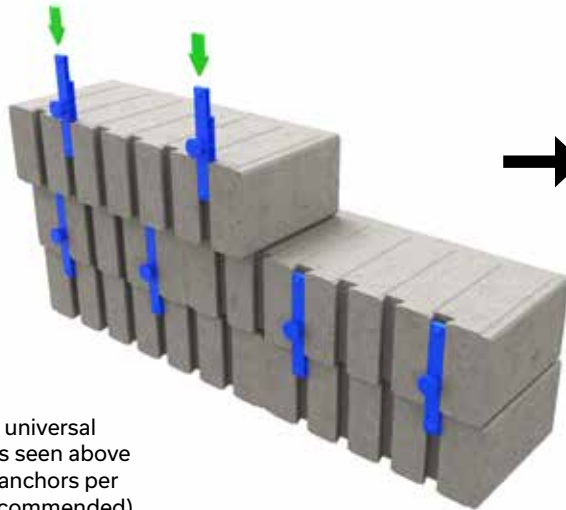

1
Slide the universal anchor as seen above (using 2 anchors per unit is recommended)

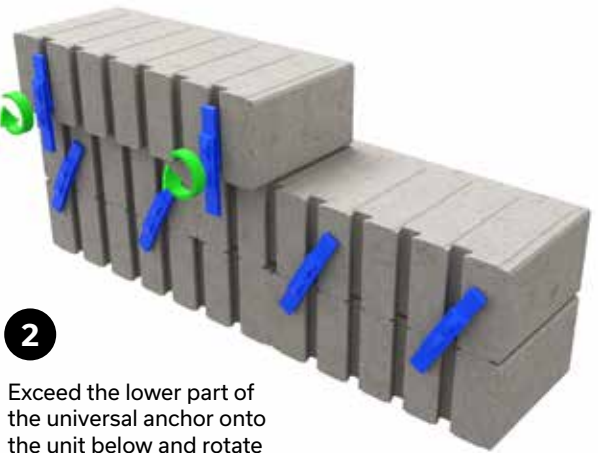

2
Exceed the lower part of the universal anchor onto the unit below and rotate the universal anchor

CROSS-SECTION VIEW

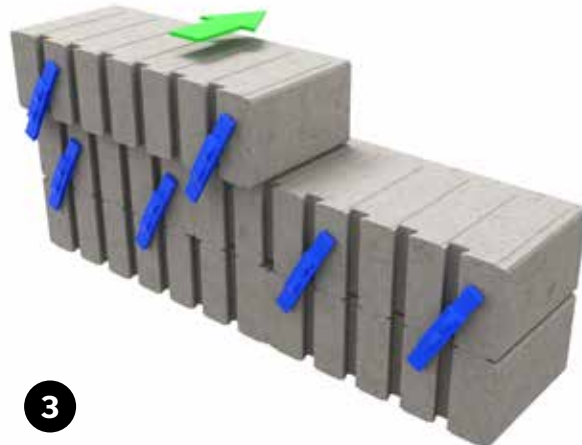

3
Pull the unit forward until it locks

URBANO WALL

CROSS-SECTION -SETBACK WALL

The following is a general cross-section of an Urbano wall construction. The height of an Urbano wall unit is 120 mm - 4 3/4 in. The maximum height of the setback Urbano wall is 6 rows.

ISOMETRIC VIEW

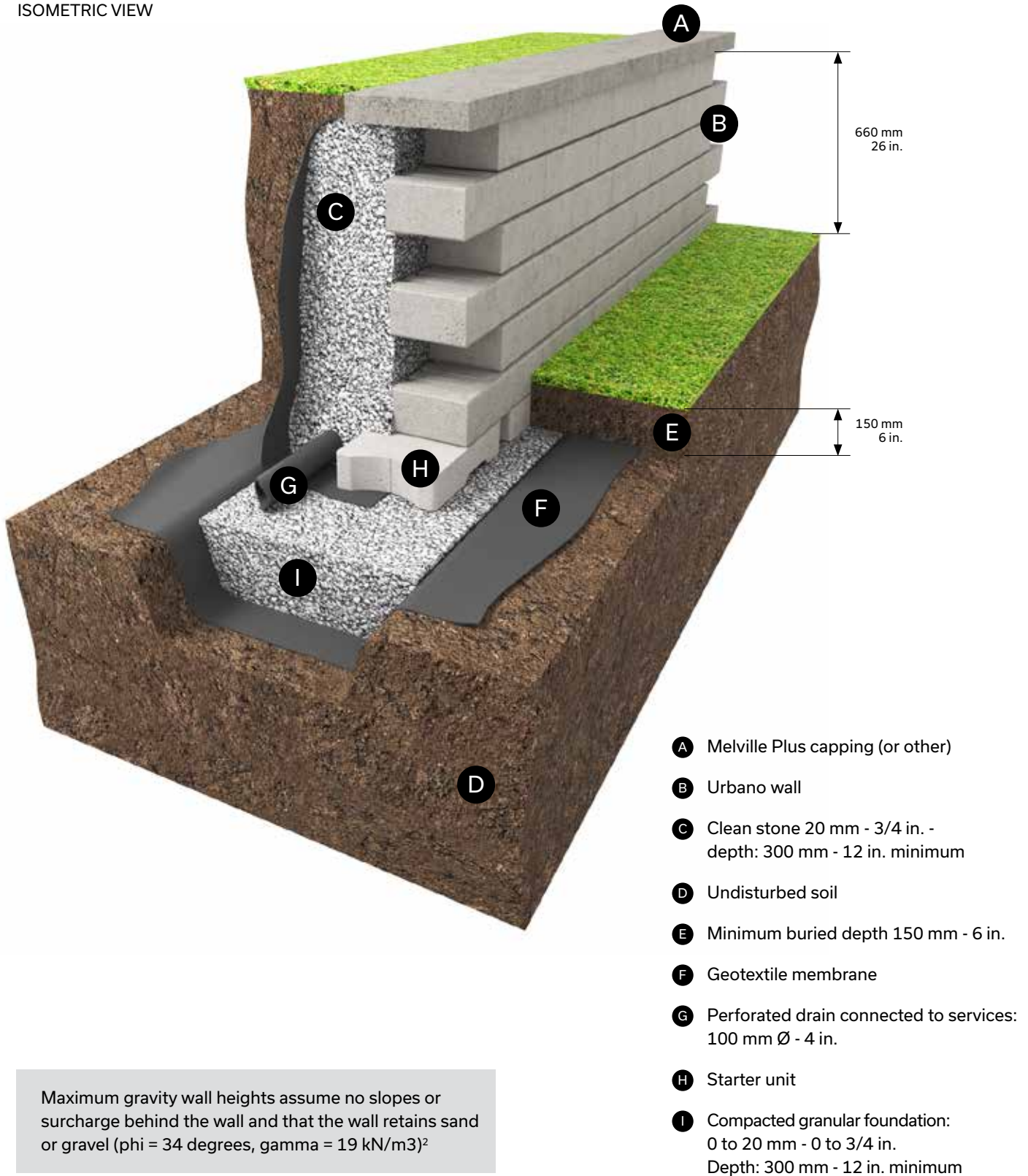

Maximum gravity wall heights assume no slopes or surcharge behind the wall and that the wall retains sand or gravel ($\phi = 34$ degrees, $\gamma = 19 \text{ kN/m}^3$)

CROSS-SECTION -SETBACK GRAVITY WALL

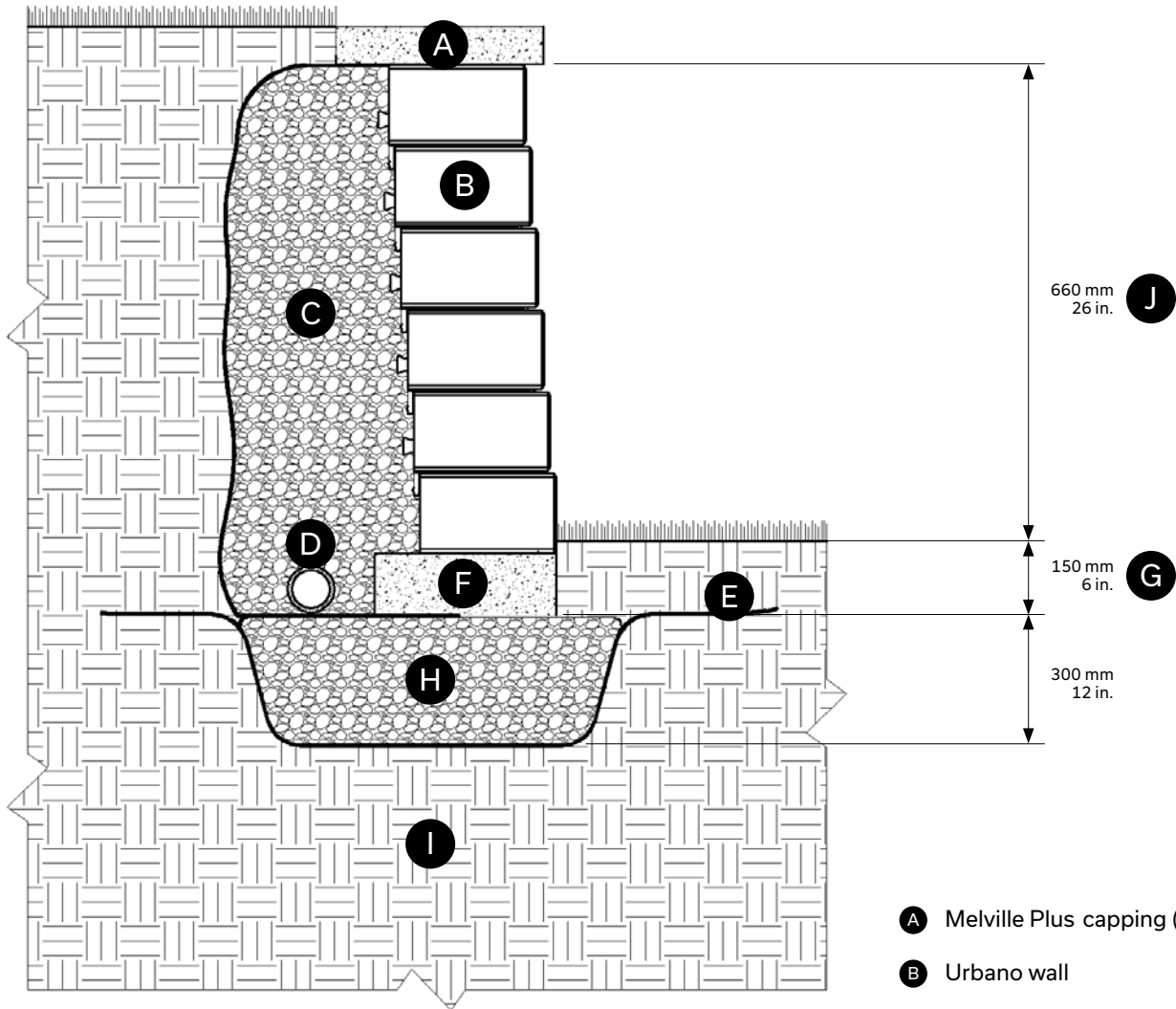

- Ⓐ Melville Plus capping (or other)
- Ⓑ Urbano wall
- Ⓒ Clean stone 20 mm - 3/4 in. - depth: 300 mm - 12 in. minimum
- Ⓓ Perforated drain connected to services: 100 mm Ø - 4 in.
- Ⓔ Geotextile membrane
- Ⓕ Starter unit
- Ⓖ Minimum buried depth 150 mm - 6 in.
- Ⓗ Compacted granular foundation: 0 to 20 mm - 0 to 3/4 in. Depth: 300 mm - 12 in. minimum
- Ⓘ Undisturbed soil
- ⓵ Maximum height without surcharges or slopes behind the wall, excluding the buried units and capping

Maximum gravity wall heights assume no slopes or surcharge behind the wall and that the wall retains sand or gravel ($\phi = 34$ degrees, $\gamma = 19$ kN/m³)

URBANO WALL

CROSS-SECTION - VERTICAL WALL

The maximum height of the Urbano vertical wall is 5 rows.

ISOMETRIC VIEW

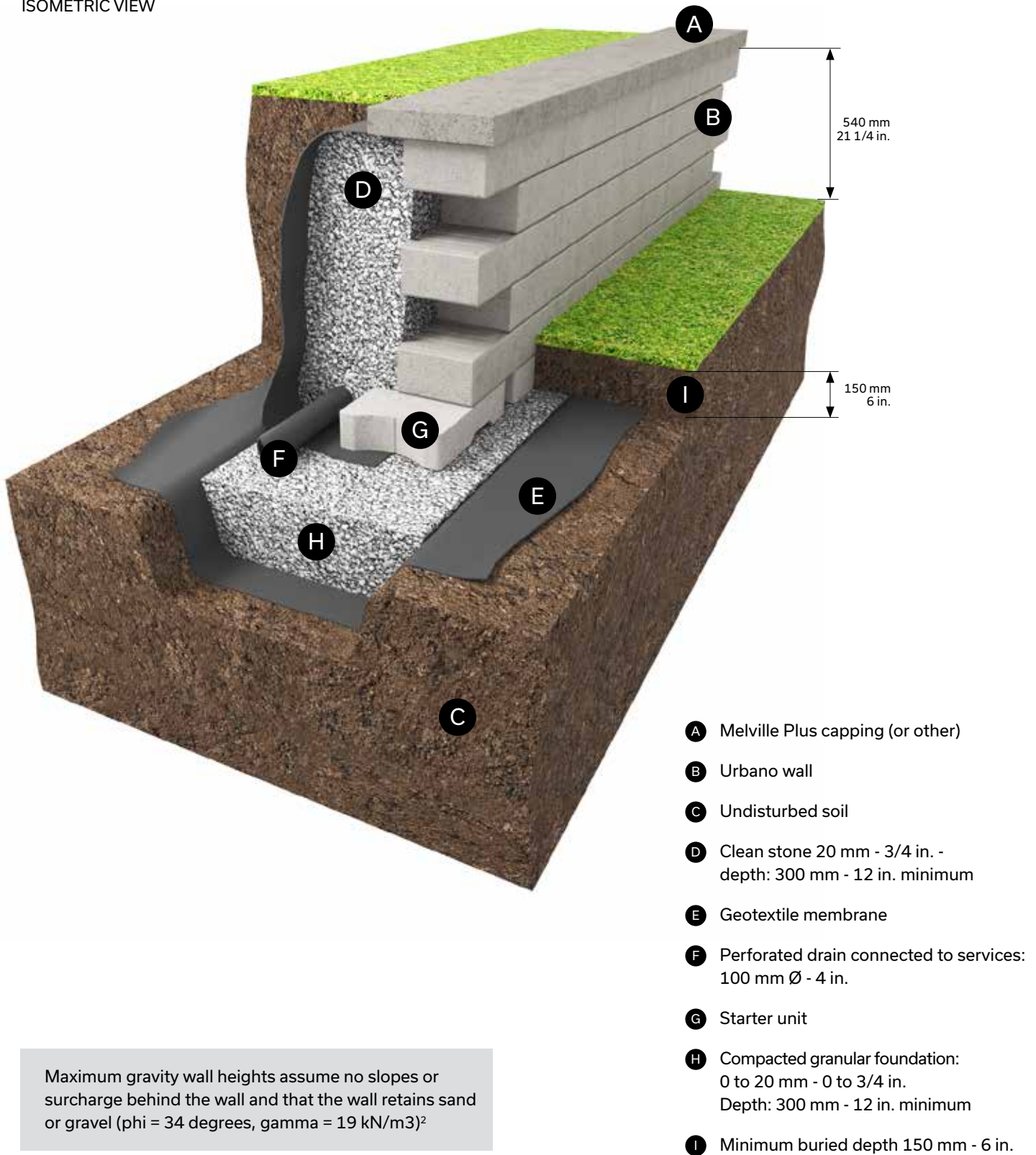

Maximum gravity wall heights assume no slopes or surcharge behind the wall and that the wall retains sand or gravel ($\phi = 34$ degrees, $\gamma = 19$ kN/m³)²

CROSS-SECTION - VERTICAL GRAVITY WALL

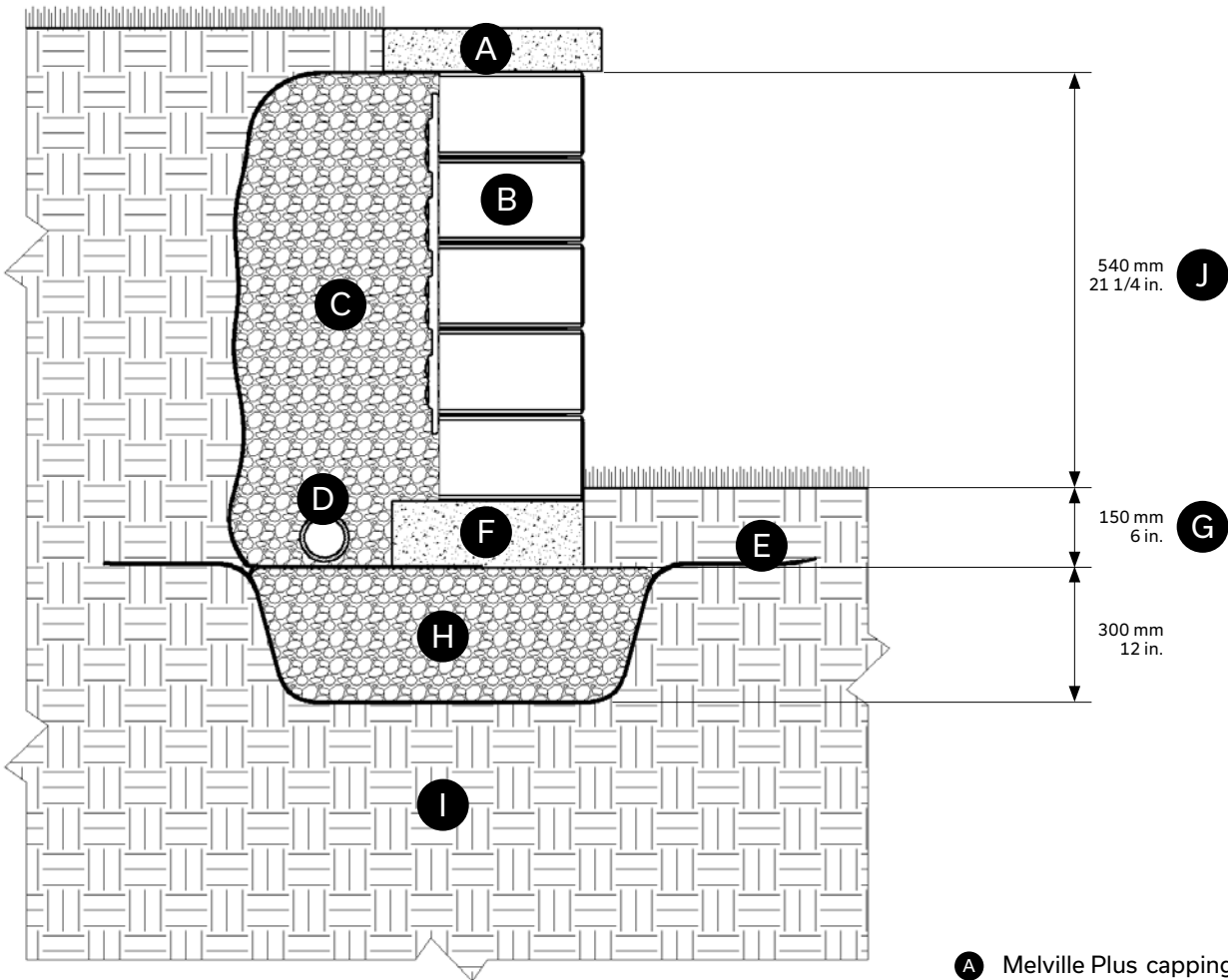

- Ⓐ Melville Plus capping (or other)
- Ⓑ Urbano wall
- Ⓒ Clean stone 20 mm - 3/4 in. - depth: 300 mm - 12 in. minimum
- Ⓓ Perforated drain connected to services: 100 mm Ø - 4 in.
- Ⓔ Geotextile membrane
- Ⓕ Starter unit
- Ⓖ Minimum buried depth 150 mm - 6 in.
- Ⓗ Compacted granular foundation: 0 to 20 mm - 0 to 3/4 in. Depth: 300 mm - 12 in. minimum
- Ⓘ Undisturbed soil
- ⓰ Maximum height without surcharges or slopes behind the wall, excluding the buried units and capping

Maximum gravity wall heights assume no slopes or surcharge behind the wall and that the wall retains sand or gravel ($\phi = 34$ degrees, $\gamma = 19$ kN/m³)

URBANO WALL

CROSS-SECTION -CREATING URBANO WALL STEPS

To create stairs, install the Melville 60 step combined with the Urbano wall units used as risers, as detailed below:

ISOMETRIC VIEW

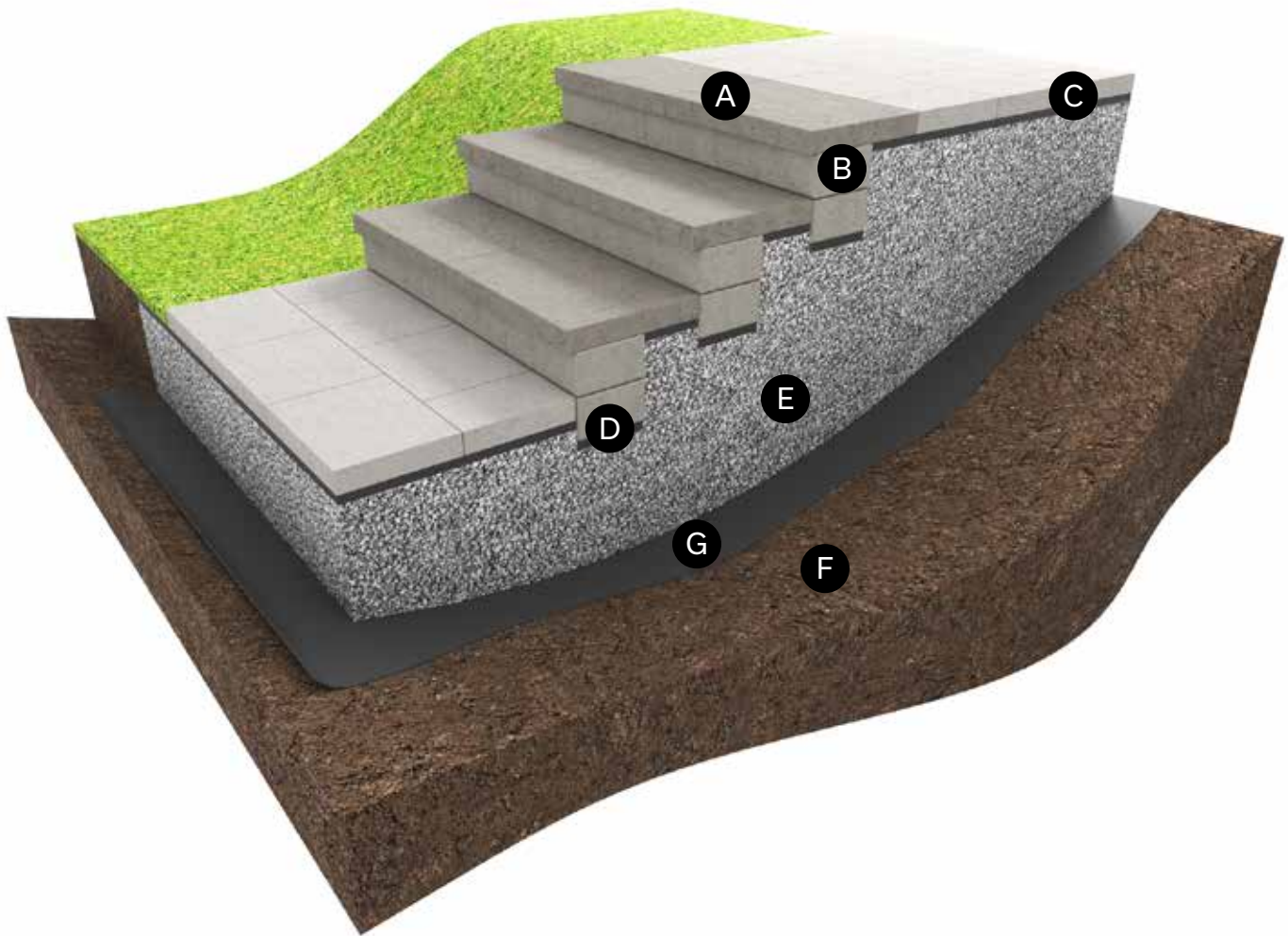

- A** Melville Plus capping (or other)
- B** Urbano wall
- C** Concrete slab: 60 mm -2 3/8 in.
- D** Laying bed: 25 mm -1 in.
- E** Compacted granular foundation:
0 to 20 mm - 0 to 3/4 in.
Depth: 300 mm - 12 in. minimum
- F** Soil in place
- G** Geotextile membrane

All step and riser units must be bonded together with Techniseal concrete adhesive.

CROSS-SECTION - WALL STEP INSTALLATION

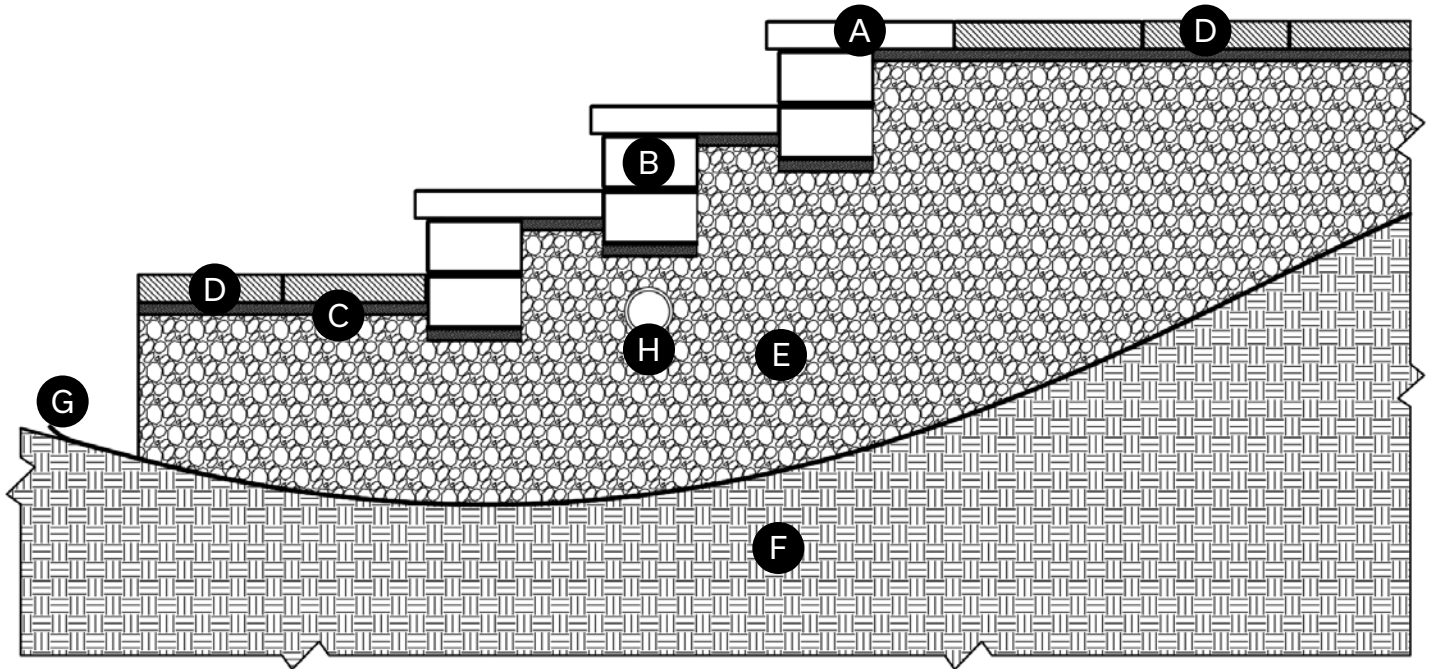

- Ⓐ Melville Plus 60 step unit
- Ⓑ Urbano wall
- Ⓒ Laying bed: 25 mm - 1 in.
- Ⓓ Concrete slab: 60 mm - 2 3/8 in.
- Ⓔ Compacted granular foundation:
0 to 20 mm - 0 to 3/4 in.
Depth: 300 mm - 12 in. minimum
- Ⓕ Soil in place
- Ⓖ Geotextile membrane
- Ⓗ Perforated drain connected to services:
100 mm Ø - 4 in.

All step and riser units must be bonded together with Techniseal concrete adhesive.

CREATING OUTER AND INNER CORNERS

ISOMETRIC VIEW - OUTER CORNER

It is recommended to always begin the construction of a retaining wall with a corner in order to avoid cuts and an alignment of vertical joints from one row to another. All Urbano wall units can be used to create a corner.



ISOMETRIC VIEW - INNER CORNER

The creation of an inner corner is based on the principle illustrated below using units A, B or C.



BUILDING A SQUARE FIREPIT

The Urbano wall can be used to create many types of firepits: propane gas, natural gas, ethanol and wood. Construction begins with the installation of a proper foundation (levelled and densified). For a wood-burning firepit, a minimum 12 mm - 1/2 in. thick fiber cement board* or refractory firebrick* is recommended to ensure adequate protection. These elements must be installed all around the interior walls of the firepit.

For a gas fire pit, it is necessary to install conduits in the ground to carry the gas pipes or even electrical wires. The suggested size below is for reference; actual dimensions will vary depending on the selected unit.

ISOMETRIC VIEW

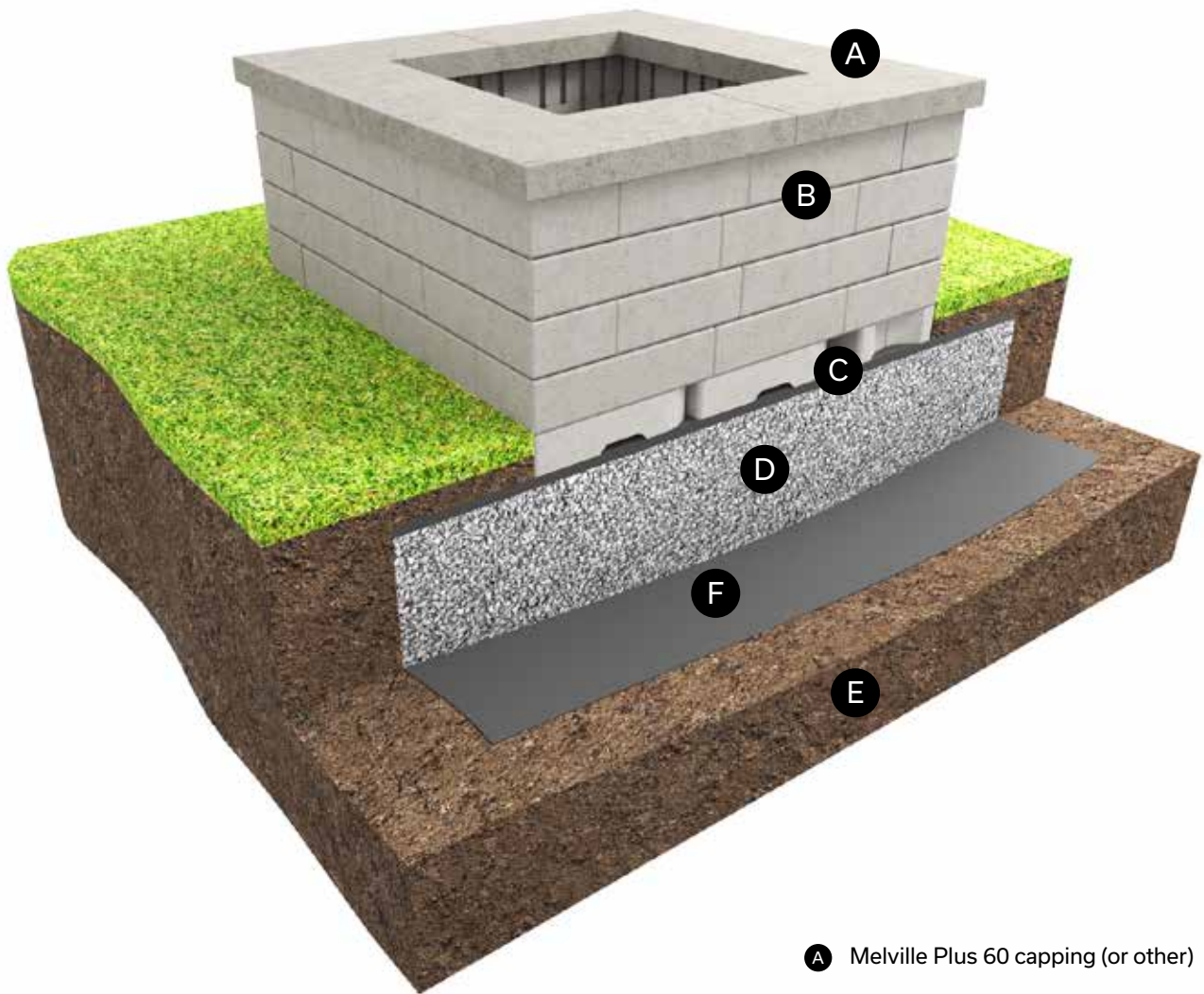

- A** Melville Plus 60 capping (or other)
- B** Urbano wall
- C** Laying bed 25 mm - 1 in.
- D** Compacted granular foundation:
0 to 20 mm - 0 to 3/4 in.
Depth: 300 mm - 12 in. minimum
- E** Soil in place
- F** Geotextile membrane

* Elements not shown in image

SQUARE FIREPIT- WALL UNITS INSTALLATION



1
Begin installation with starter units

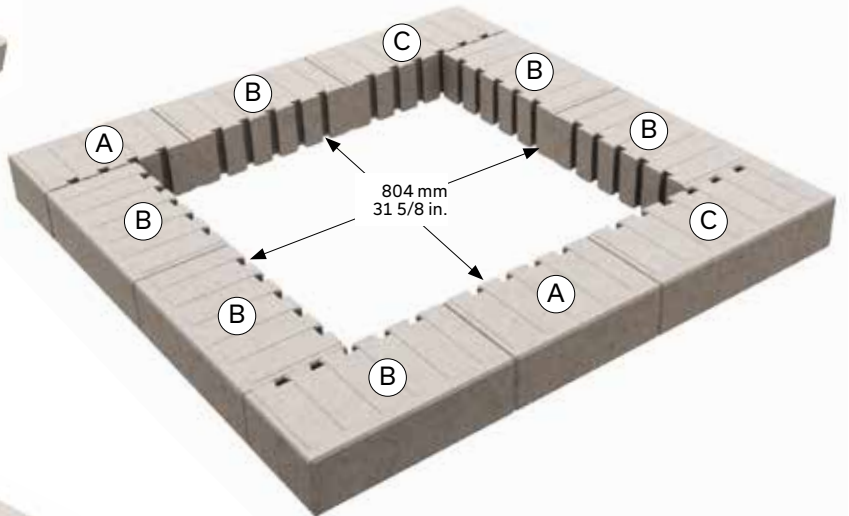

2
2nd row: install Urbano wall units by following this diagram

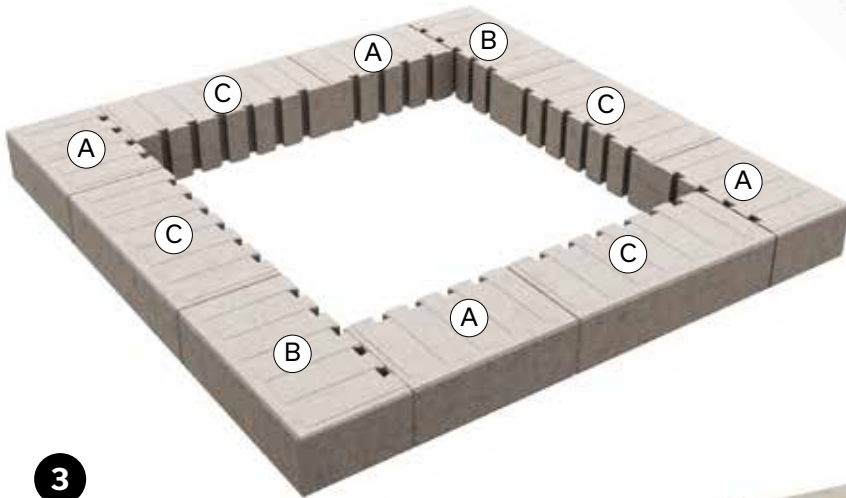

3
3rd row: proceed with installation by following this diagram

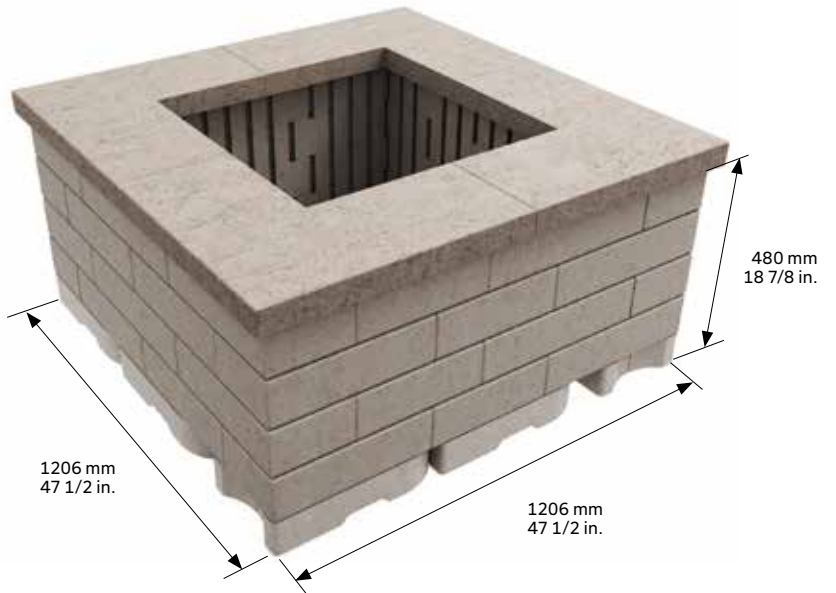

4
4th row: proceed with installation by repeating 2nd row diagram

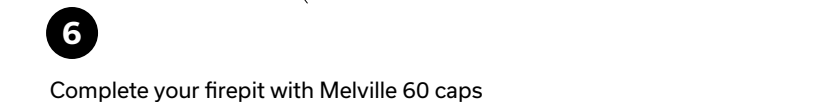

5
5th row: proceed with installation by repeating 3rd row diagram

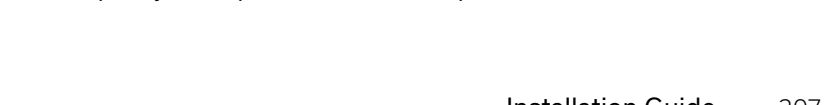

6
Complete your firepit with Melville 60 caps

BUILDING A RECTANGULAR FIREPIT

The rectangular format is primarily geared toward a propane or natural gas firepit. Its dimensions will need to be adapted according to the type of firepit selected. We recommend that you consult with a gas fitter or inquire about local codes and regulations before proceeding with a gas firepit installation.

In addition, it will be necessary to install conduits in the ground to carry gas pipes or even electrical wires, if required.

ISOMETRIC VIEW

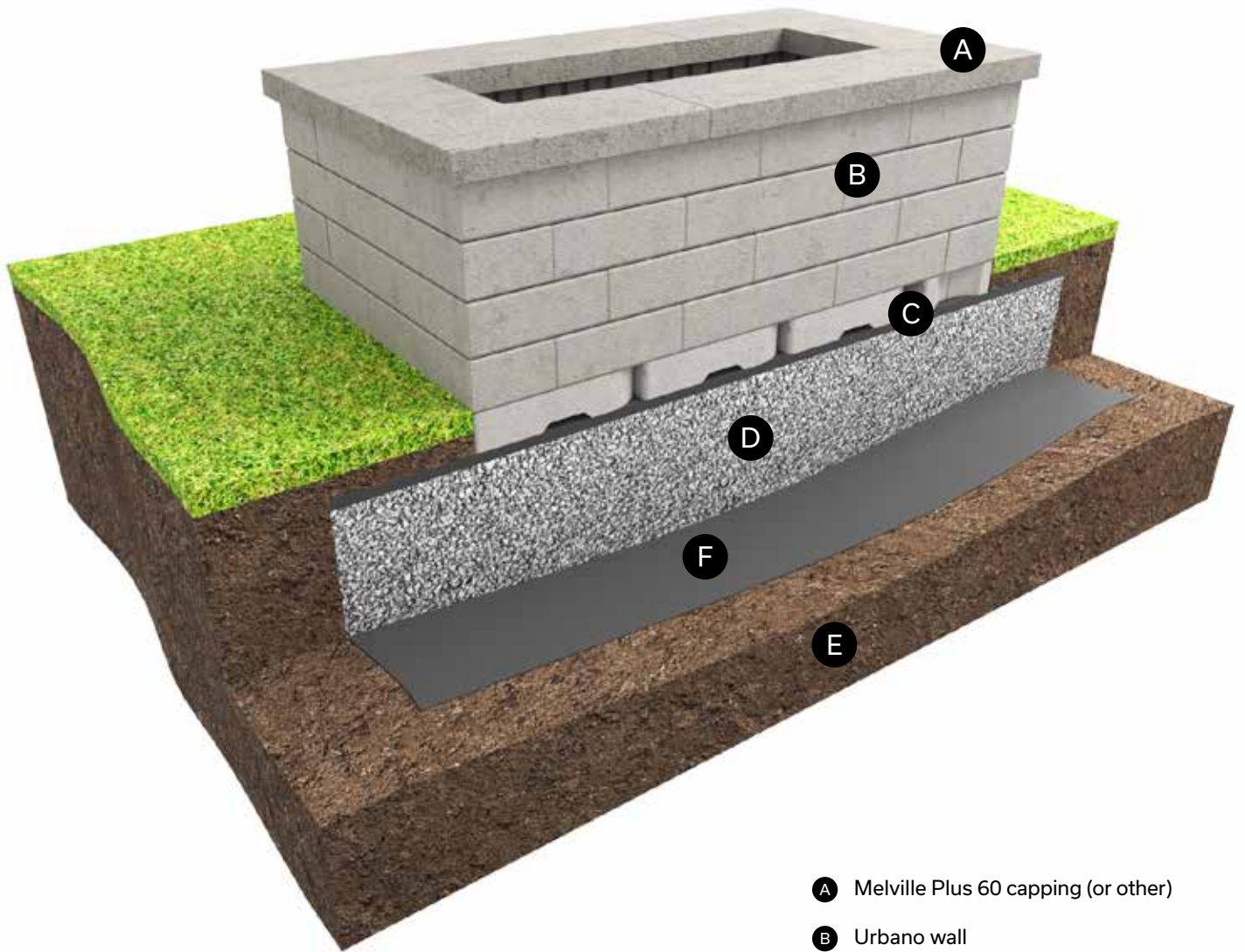

- Ⓐ Melville Plus 60 capping (or other)
- Ⓑ Urbano wall
- Ⓒ Laying bed 25 mm - 1 in.
- Ⓓ Compacted granular foundation:
0 to 20 mm - 0 to 3/4 in.
Depth: 300 mm - 12 in. minimum
- Ⓔ Soil in place
- Ⓕ Geotextile membrane

RECTANGULAR FIREPIT-WALL UNITS INSTALLATION



1

Begin installation with starter units

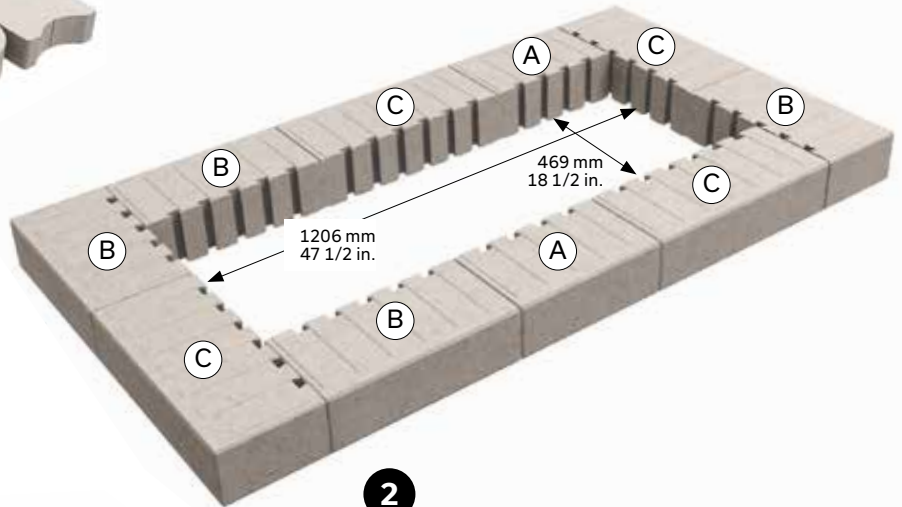

2

2nd row: install Urbano wall units by following this diagram

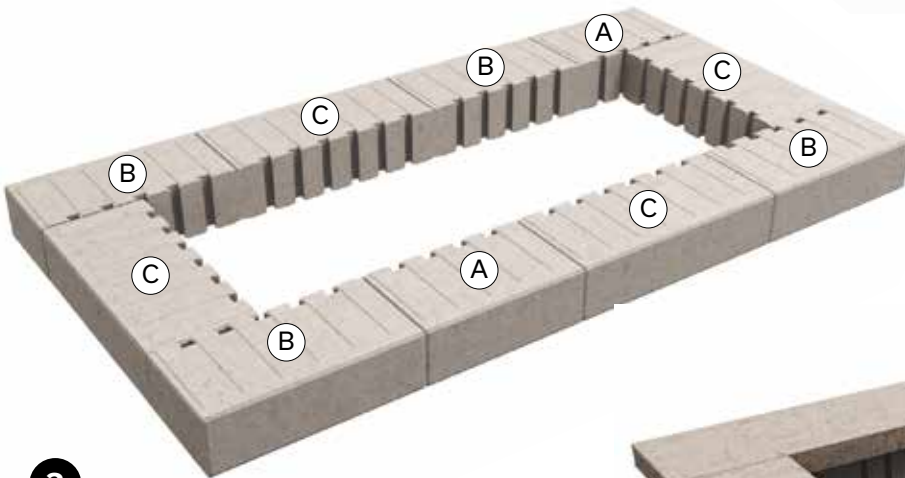

3

3rd row: proceed with installation by following this diagram

4

4th row: proceed with installation by repeating 2nd row diagram

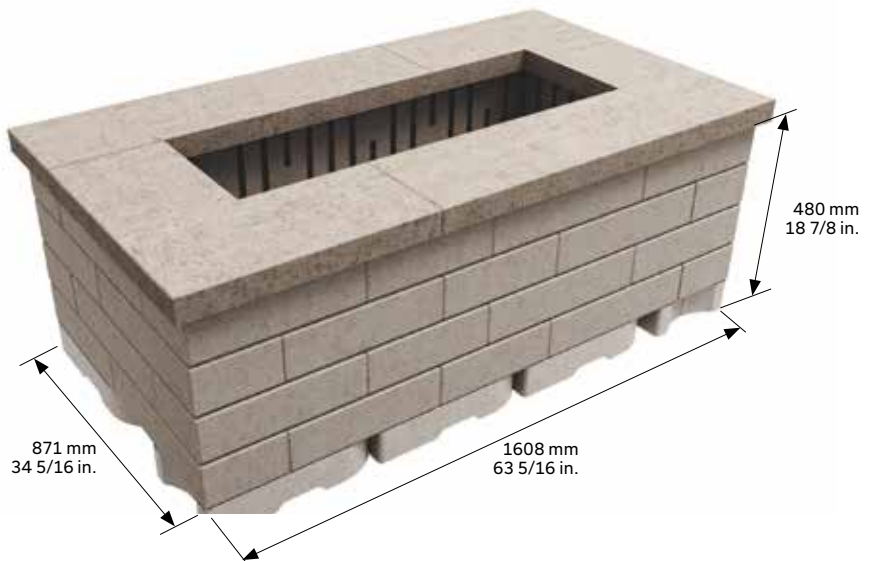

5

5th row: proceed with installation by repeating 3rd row diagram

6

Complete your firepit with Melville 60 caps

Vario Wall

DESCRIPTION



The Vario wall, the wall that does it all. Install a block unit, slide another one over it, and so on. This results in a modern wall with clean lines.

Versatile and innovative, this product can be used for retaining walls, creating privacy spaces and outdoor kitchens. Available in two heights (90 or 180 mm), the Vario wall is perfect for steps and modular installations.

Note that all units are double-sided, and that they are all (including corner units) on the same pallet. Their popular colours fit perfectly with Permacon's numerous cappings.

BENEFITS:

- > Quick and easy to install
- > No accessories required
- > All double-sided units
- > 90 mm and 180 mm heights, ideal for steps and modular installations
- > Smooth texture
- > Available in trendy colours that match slabs, pavers and capping units
- > Build retaining walls, raised gardens, double-sided walls, outdoor kitchens, and more!

The information contained in these technical documents is supplied for information purposes only. Any application of the information is the sole responsibility of the installer. The installer must ensure that the installation and use of retaining wall projects comply with local regulations and code requirements. A qualified engineer must be consulted for final design for construction purposes. Oldcastle Building Products Canada, Inc. and its affiliates cannot be held responsible for the improper use of information contained in these technical documents.

90 mm UNITS

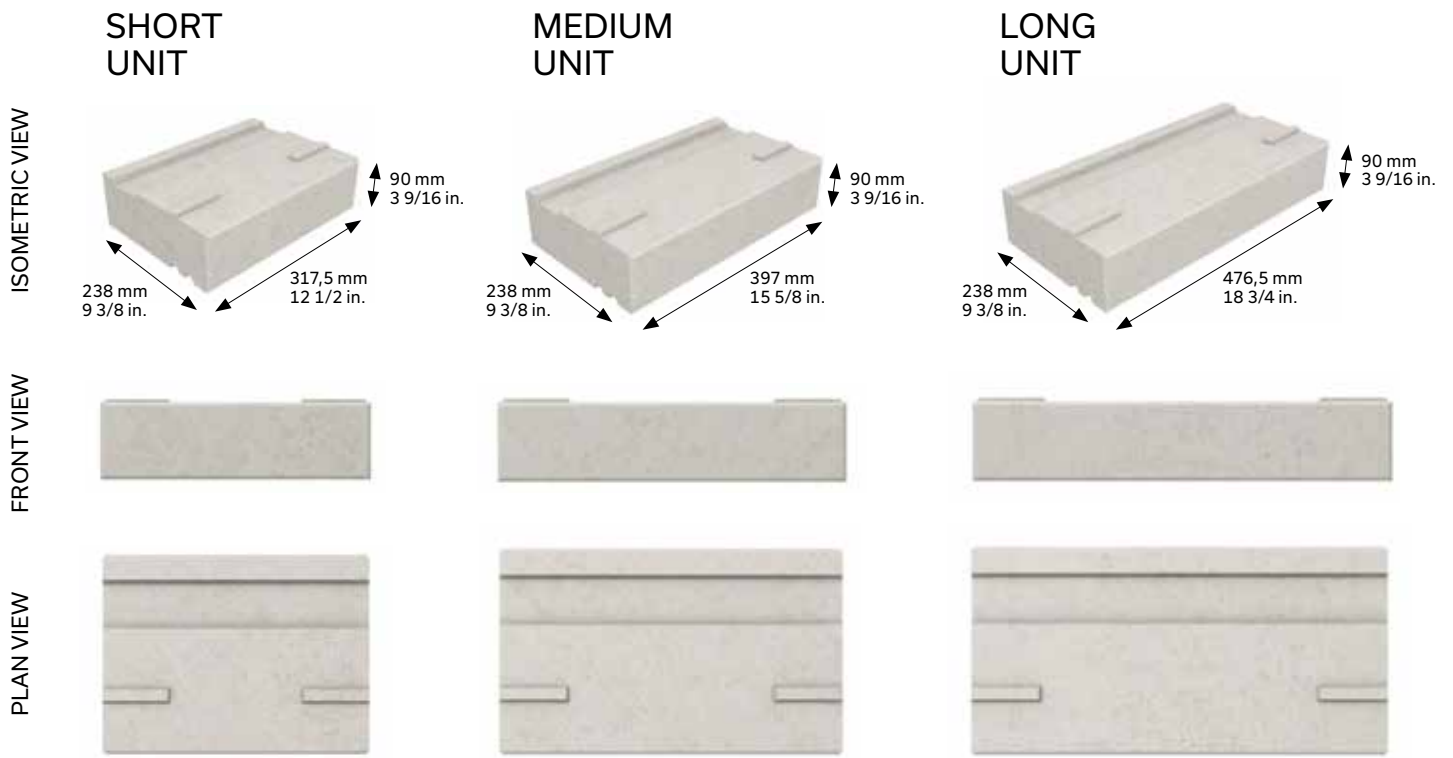

Note that Short, Medium and Long units are packaged on the same cube.

90 mm RIGHT CORNER UNITS

Only Long and Medium units are available as corners. On corner units, the groove does not run the full length.

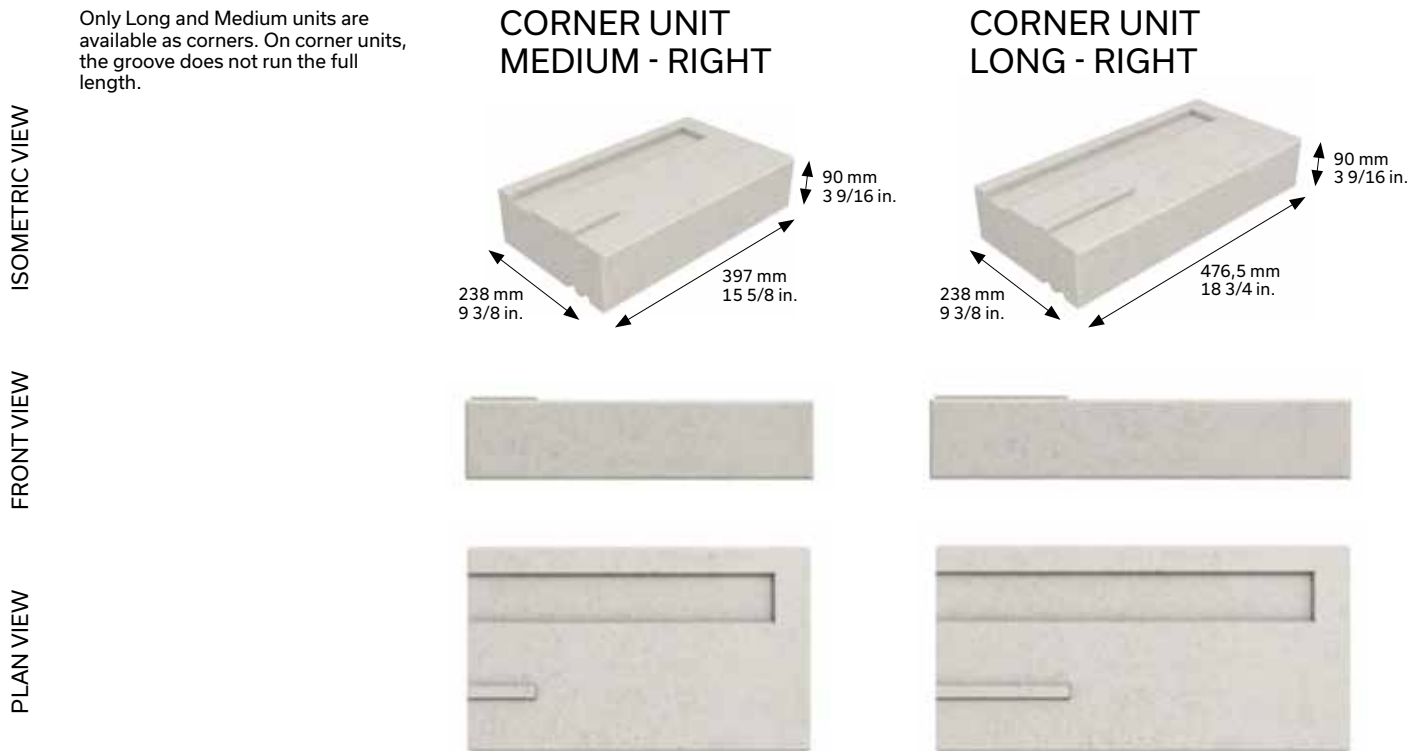

90 mm LEFT CORNER UNITS

Only Long and Medium units are available as corners. On corner units, the groove does not run the full length.

CORNER UNIT MEDIUM - LEFT

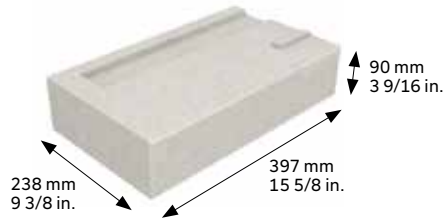

CORNER UNIT LONG - LEFT

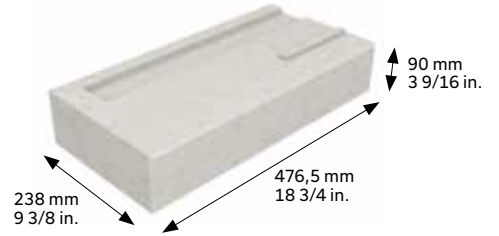

ISOMETRIC VIEW

FRONT VIEW



PLAN VIEW

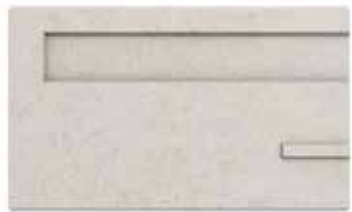

BASIC PRINCIPLES

90 mm medium left corner unit

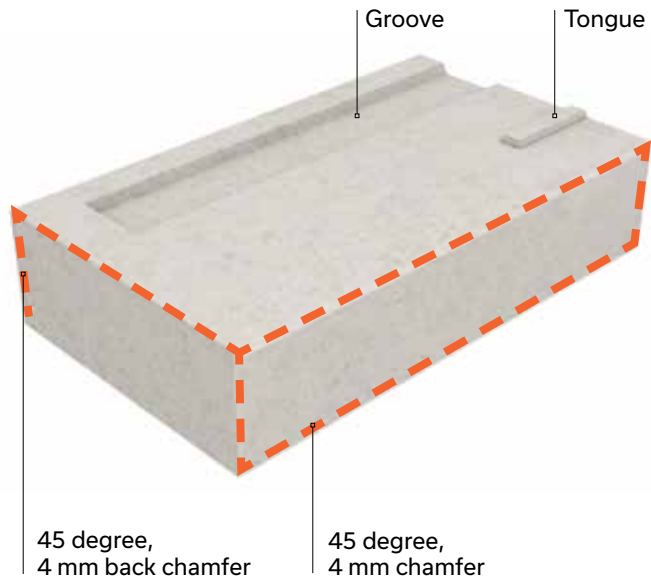

90 mm medium underside unit

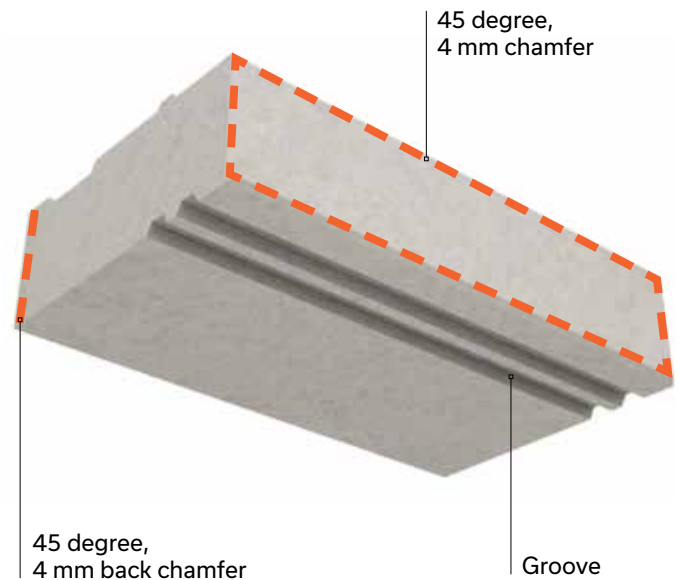

ADDING CAPPING TO A VARIO WALL - LAST ROW

On the last row of the Vario wall, reverse the unit so that the tongues are facing down. Then, use Techniseal concrete adhesive to glue the Permacon capping of your choice.

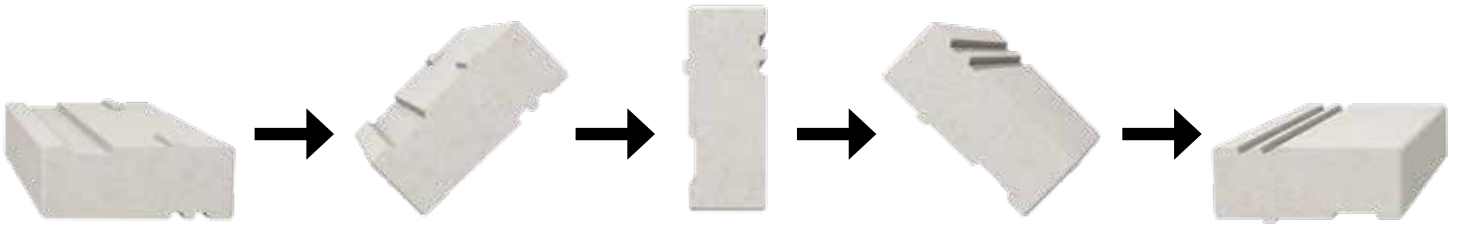

TYPICAL ROW

4 integrated corners per row: 1 right long, 1 right medium, 1 left long, 1 left medium

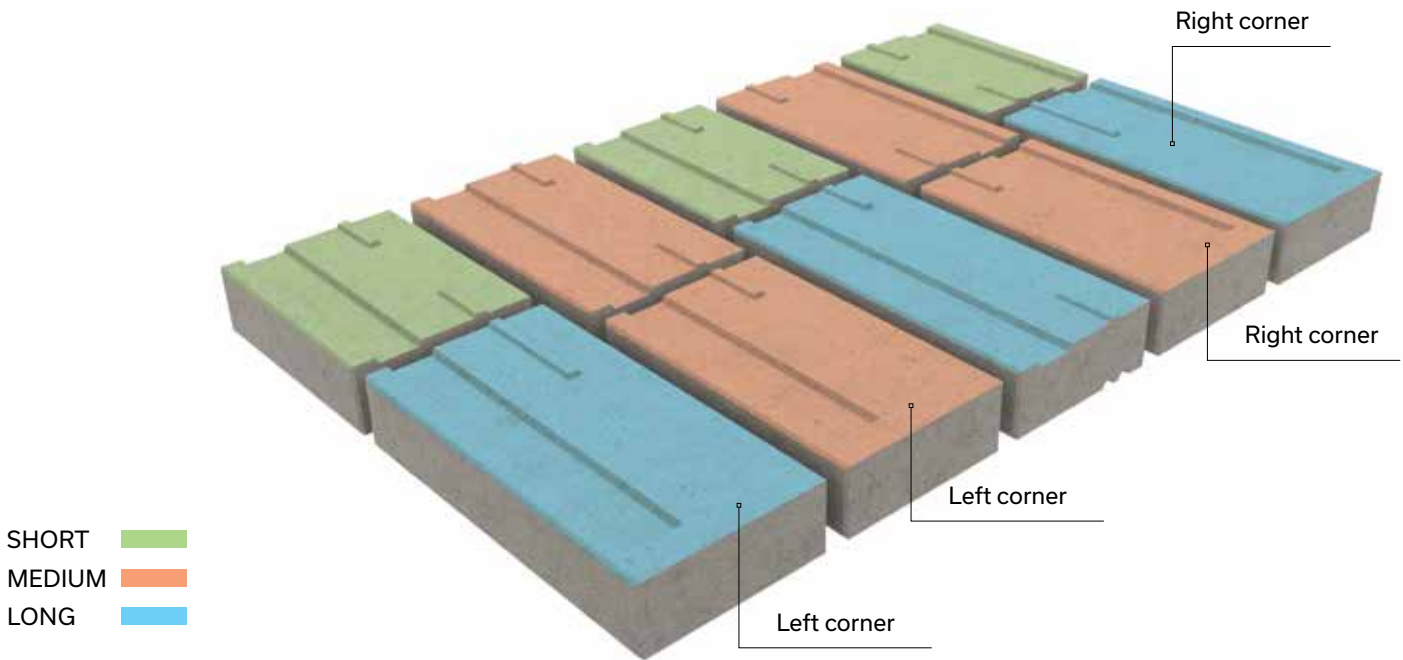

TECHNICAL INFORMATION

	MAX HEIGHT ft.	MAX HEIGHT m.	SETBACK degrees	QUANTITY ft ²	QUANTITY m ²
Setback	3.56*	1.08*	9.46	Variable	Variable
Straight	2.33*	0.72*	—	Variable	Variable

* The listed heights are maximum heights without geogrid. The Vario Wall can be installed using geogrid allowing the wall to reach heights of 2.7 m or 8 3/4 ft.

LAYING PATTERNS

LINEAR PATTERN - 100% VARIO 90

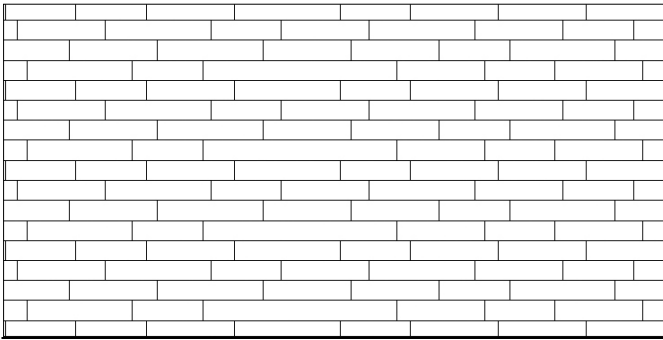

LINEAR PATTERN - 100% VARIO 180

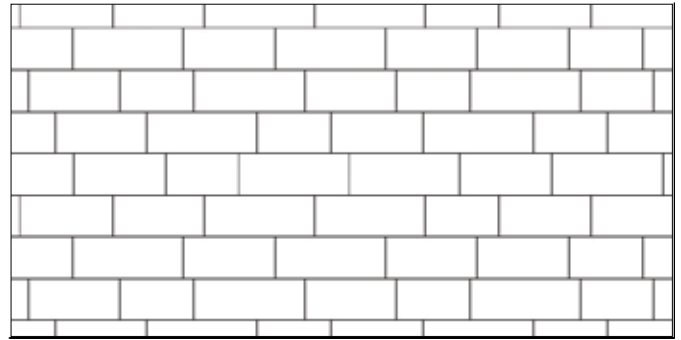

MODULAR PATTERN - 50% VARIO 90 AND 50% VARIO 180

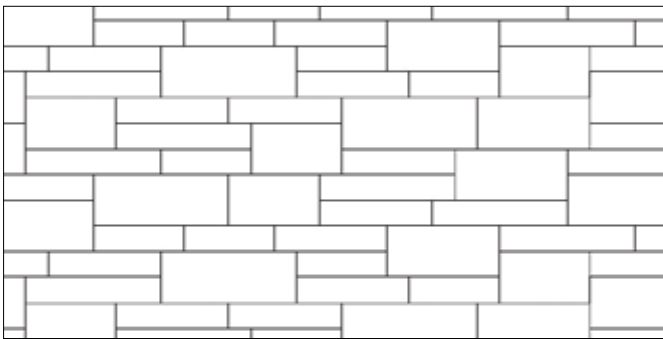

CREATING OUTER AND INNER CORNERS

It is recommended to always begin the construction of a retaining wall with a corner in order to avoid cuts and an alignment of vertical joints from one row to another. We advise the use of Techniseal concrete adhesive to glue the corner units together to ensure increased stability.



ISOMETRIC VIEW - OUTER CORNER



ISOMETRIC VIEW - INNER CORNER

VARIO WALL 90 mm

CROSS-SECTION - SETBACK WALL

Vario Wall 90 mm installed with a setback (30 mm per row) can go up to 12 rows (total height of 1080 mm or 42 3/4 in.)

- > Create the setback by installing the outer groove (female) on the tongue (male) at every row
- > At the very last row, turn the unit upside down to have the tongues downward. Then, use Techniseal concrete adhesive to glue the capping unit of your choice.

No accessory required for the Vario Wall. You don't have to use concrete adhesive between each row of the Vario Wall.

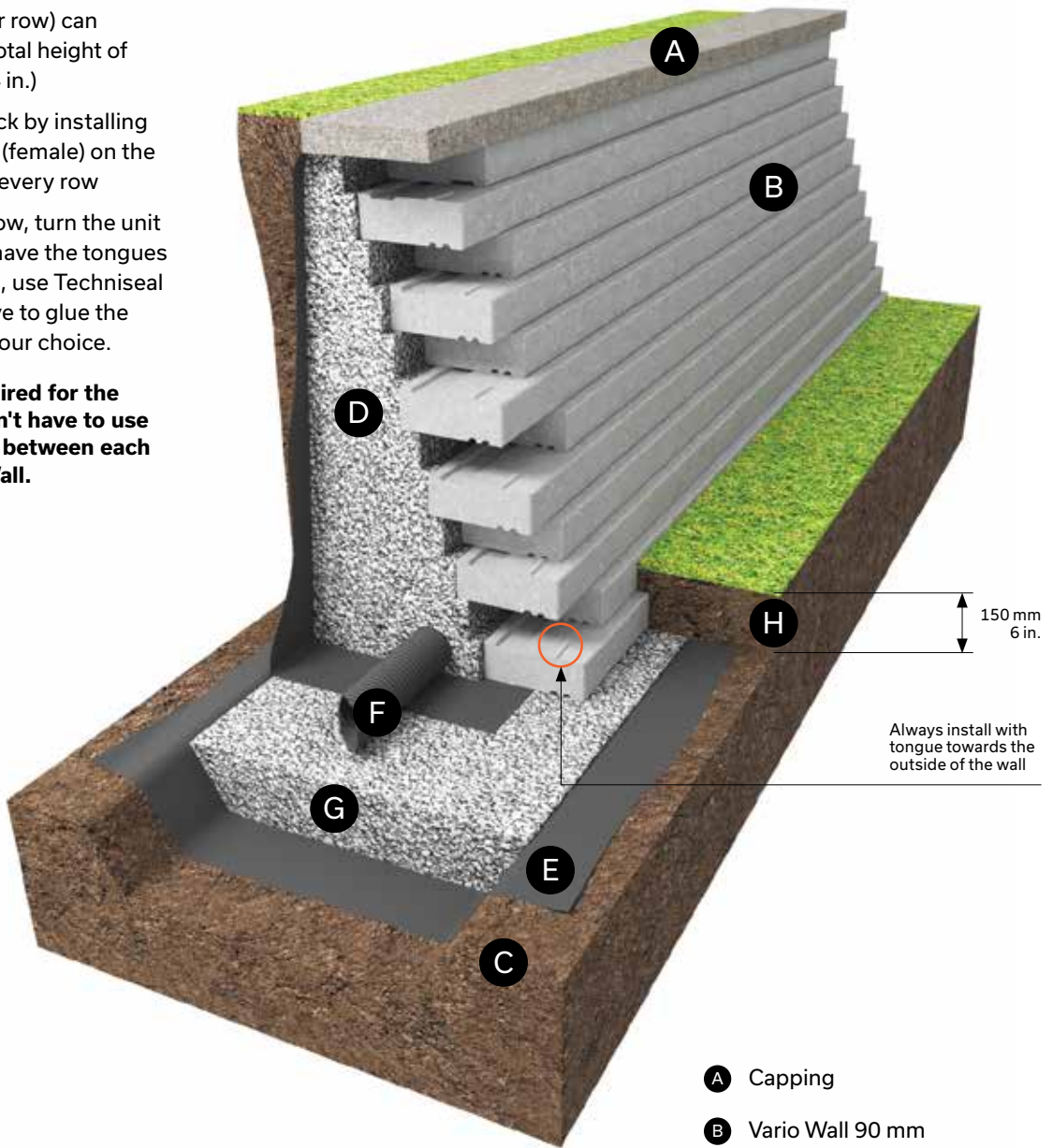

ISOMETRIC VIEW

- Ⓐ Capping
- Ⓑ Vario Wall 90 mm
- Ⓒ Undisturbed soil
- Ⓓ Clean stone 20 mm - 3/4 in. - Depth: 300 mm - 12 in. minimum
- Ⓔ Geotextile membrane
- Ⓕ Perforated drain connected to services: 100 mm Ø - 4 in.
- Ⓖ Compacted granular foundation: 0 to 20 mm - 0 to 3/4 in. Depth: 300 mm - 12 in. minimum
- Ⓗ Minimum buried depth 150 mm - 6 in.

Maximum gravity wall heights assume no slopes or surcharge behind the wall and that the wall retains sand or gravel ($\phi = 34$ degrees, $\gamma = 19 \text{ kN/m}^3$)²

CROSS-SECTION - SETBACK GRAVITY WALL

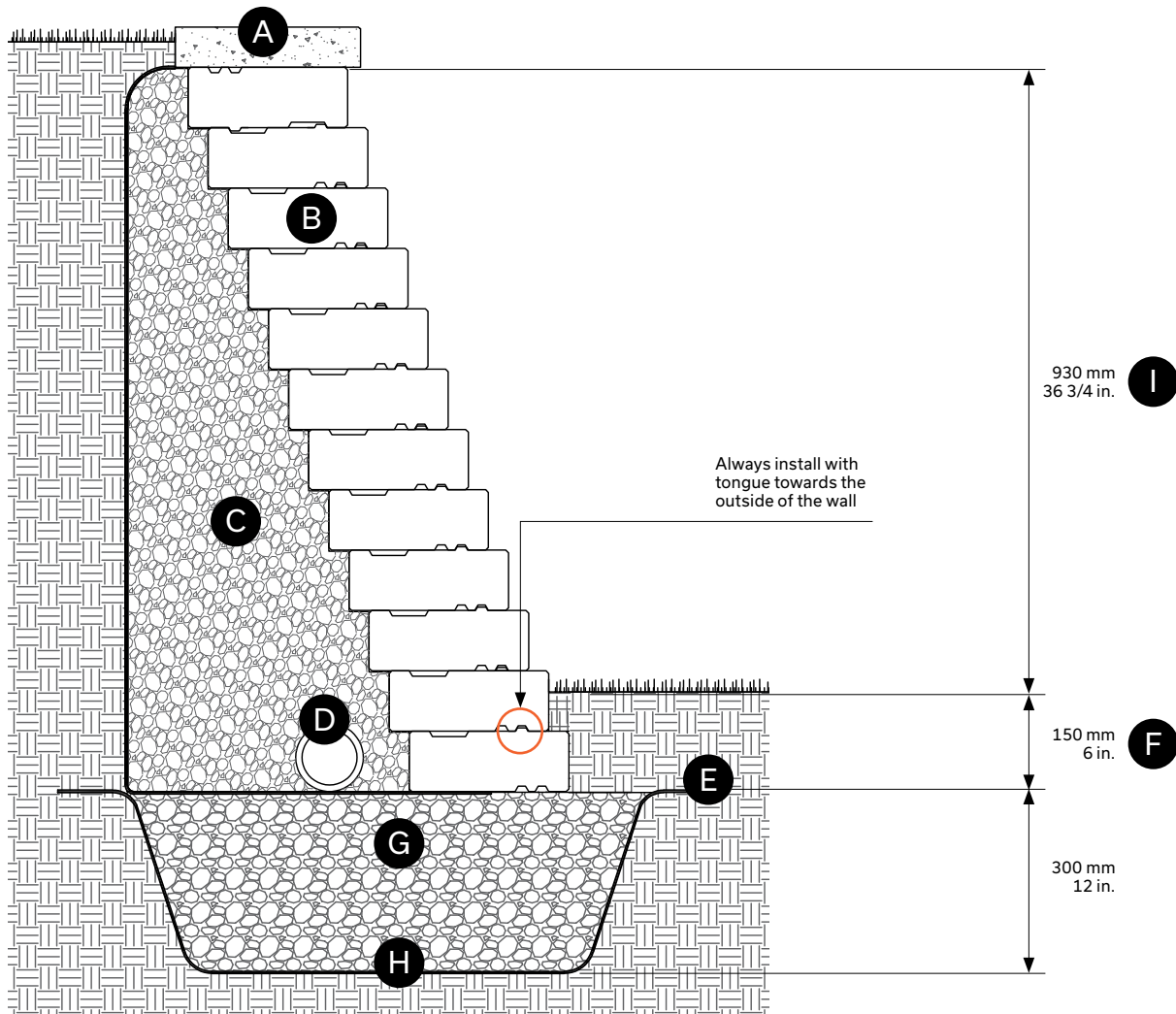

- A Capping
- B Vario Wall 90 mm
- C Clean stone 20 mm - 3/4 in. - Depth: 300 mm - 12 in. min.
- D Perforated drain connected to services: 100 mm Ø - 4 in.
- E Geotextile membrane
- F Minimum buried depth 150 mm - 6 in.
- G Compacted granular foundation: 0 to 20 mm - 0 to 3/4 in. Depth: 300 mm - 12 in. minimum
- H Undisturbed soil
- I Maximum height without surcharges or slopes behind the wall, excluding the buried units and capping

Maximum gravity wall heights assume no slopes or surcharge behind the wall and that the wall retains sand or gravel ($\phi = 34$ degrees, $\gamma = 19 \text{ kN/m}^3$)²

VARIO WALL 90 mm

CROSS-SECTION - VERTICAL WALL

Vario Wall 90 mm installed in a vertical application can go up to 8 rows (total height of 720 mm or 28 in).

> At the very last row, turn the unit upside down to have the tongues downward. Then, use Techniseal concrete adhesive to glue the capping unit of your choice.

No accessory required for the Vario Wall. You don't have to use concrete adhesive between each row of the Vario Wall.

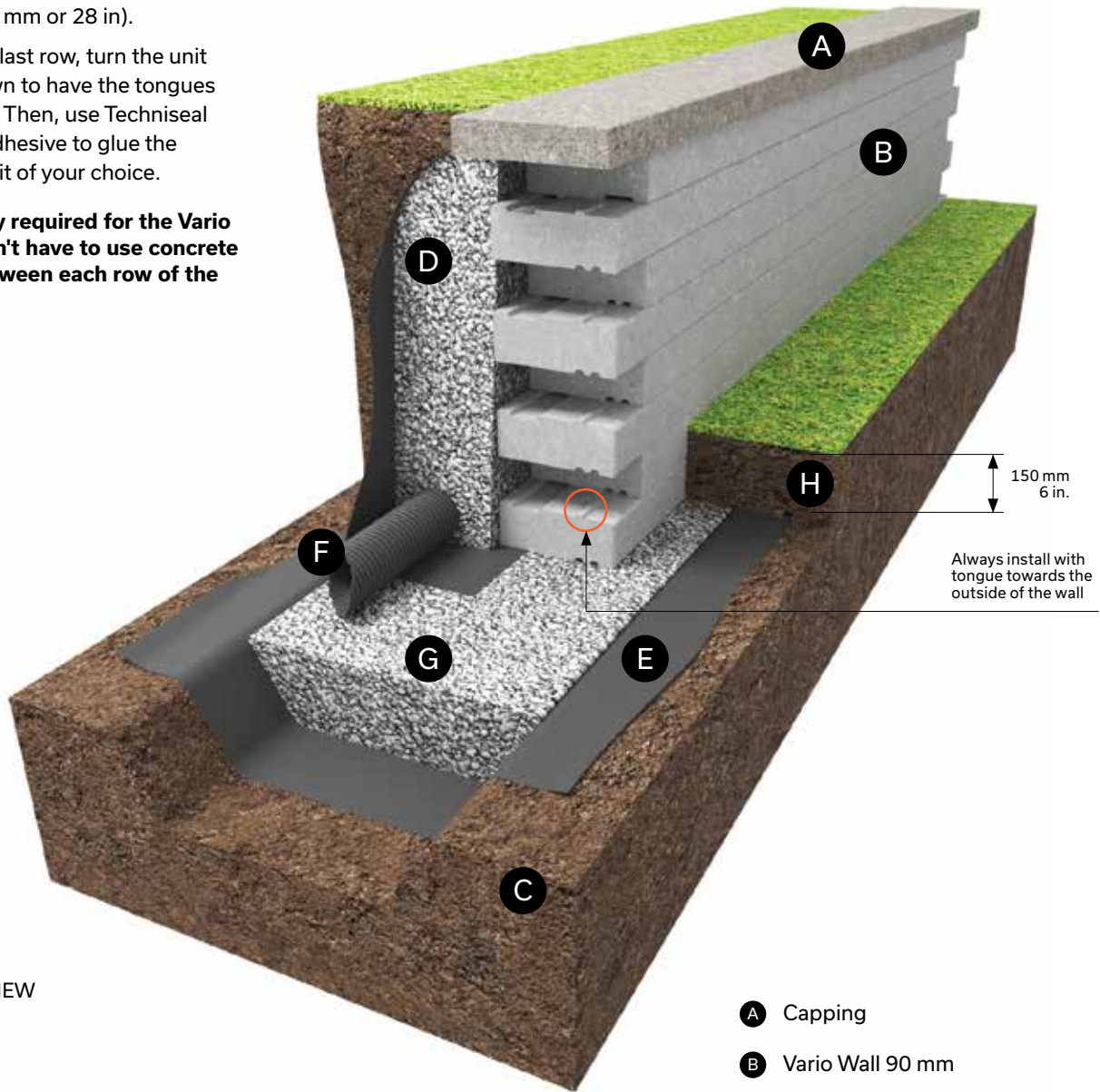

ISOMETRIC VIEW

- Ⓐ Capping
- Ⓑ Vario Wall 90 mm
- Ⓒ Undisturbed soil
- Ⓓ Clean stone 20 mm - 3/4 in. -
Depth: 300 mm - 12 in. minimum
- Ⓔ Geotextile membrane
- Ⓕ Perforated drain connected to services:
100 mm Ø - 4 in.
- Ⓖ Compacted granular foundation:
0 to 20 mm - 0 to 3/4 in.
Depth: 300 mm - 12 in. minimum
- Ⓗ Minimum buried depth 150 mm - 6 in.

Maximum gravity wall heights assume no slopes or surcharge behind the wall and that the wall retains sand or gravel ($\phi = 34$ degrees, $\gamma = 19$ kN/m³)²

CROSS-SECTION - VERTICAL GRAVITY WALL

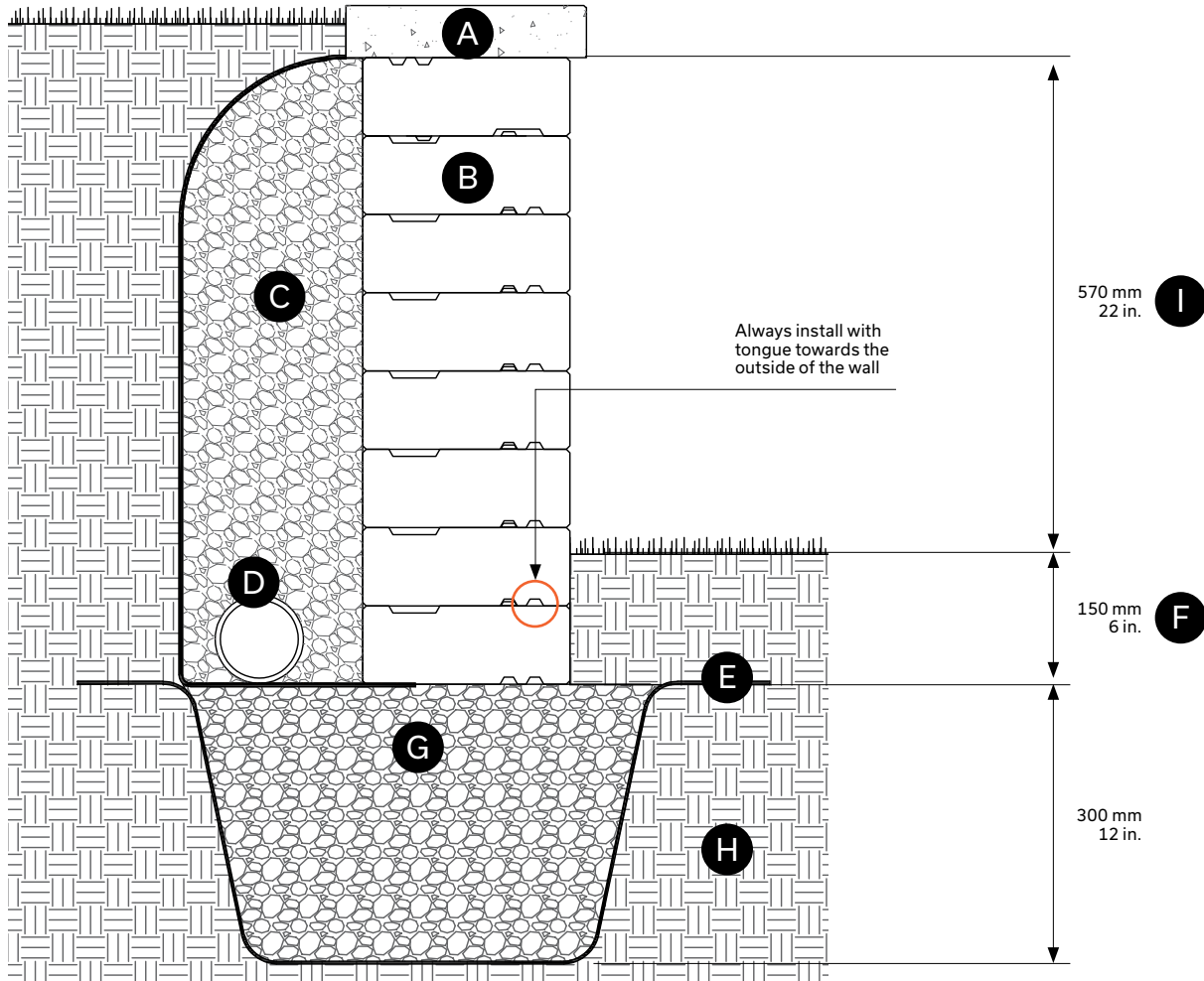

- A Capping
- B Vario Wall 90 mm
- C Clean stone 20 mm - 3/4 in. - Depth: 300 mm - 12 in. min.
- D Perforated drain connected to services: 100 mm Ø - 4 in.
- E Geotextile membrane
- F Minimum buried depth 150 mm - 6 in.
- G Compacted granular foundation: 0 to 20 mm - 0 to 3/4 in. Depth: 300 mm - 12 in. minimum
- H Undisturbed soil
- I Maximum height without surcharges or slopes behind the wall, excluding the buried units and capping

Maximum gravity wall heights assume no slopes or surcharge behind the wall and that the wall retains sand or gravel ($\phi = 34$ degrees, $\gamma = 19$ kN/m³)²

VARIO WALL 90 mm

CROSS-SECTION - DOUBLE-SIDED WALL

Vario Wall 90 mm installed in a double-sided application can go up to 10 rows (total height of 900 mm or 35 in.)

- > It is required to use concrete adhesive between each row of Vario Wall when installed in a double-sided application
- > At the very last row, turn the unit upside down to have the tongues downward. Then, use Techniseal concrete adhesive to glue the capping unit of your choice.

No accessory required for the Vario Wall.

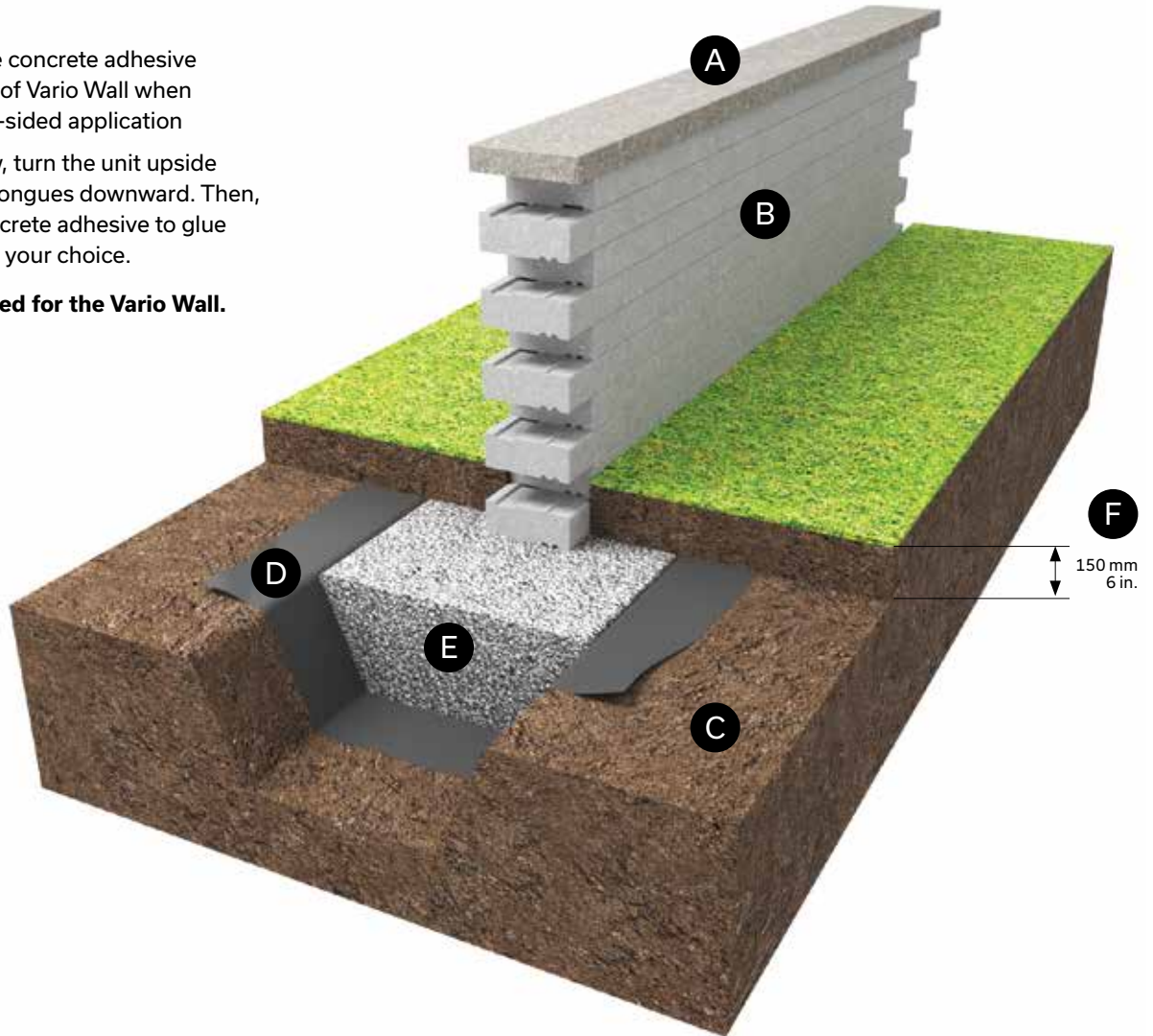

ISOMETRIC VIEW

- Ⓐ Capping
- Ⓑ Vario Wall 90 mm
- Ⓒ Undisturbed soil
- Ⓓ Geotextile membrane
- Ⓔ Compacted granular foundation: 0 to 20 mm - 0 to 3/4 in.
Depth: 300 mm - 12 in. minimum
- Ⓕ Minimum buried depth 150 mm - 6 in.

Maximum double-sided wall heights assume there is no soil to retain nor any surcharge

CROSS-SECTION - DOUBLE-SIDED WALL

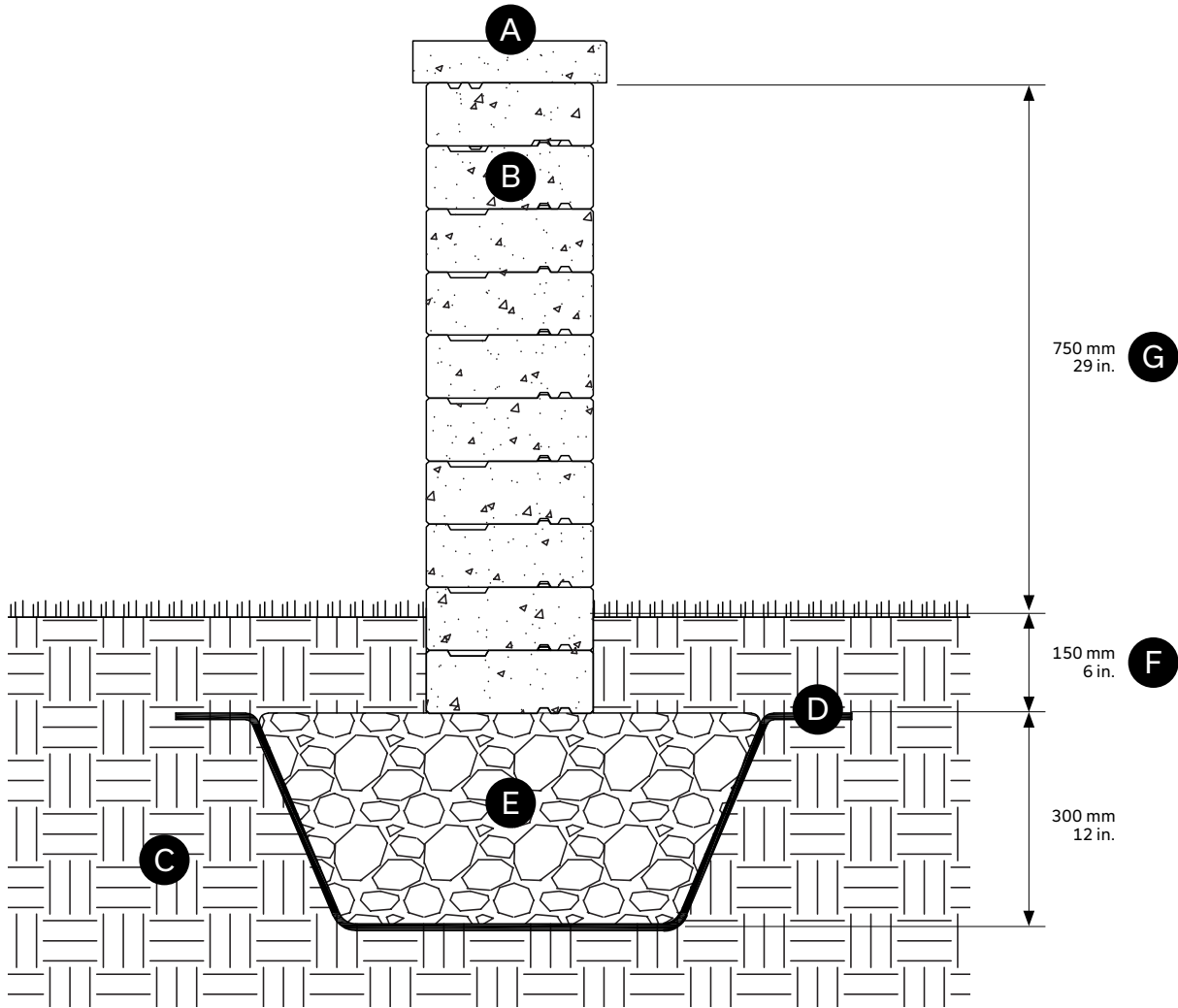

- Ⓐ Capping
- Ⓑ Vario Wall 90 mm
- Ⓒ Undisturbed soil
- Ⓓ Geotextile membrane
- Ⓔ Compacted granular foundation: 0 to 20 mm - 0 to 3/4 in.
Depth: 300 mm - 12 in. minimum
- Ⓕ Minimum buried depth 150 mm - 6 in.
- Ⓖ Maximum height without soil behind the wall, excluding the buried units and capping

CROSS-SECTION - CREATING VARIO WALL STEPS

To create steps, install the Melville Plus 90 step combined with the Vario wall units used as risers, as detailed below:

To complete the last row, turn the exposed unit upside down to have the tongues downward. Then, use Techniseal concrete adhesive to glue the step unit.

No accessory required for the Vario Wall. You don't have to use concrete adhesive between each row of the Vario Wall.

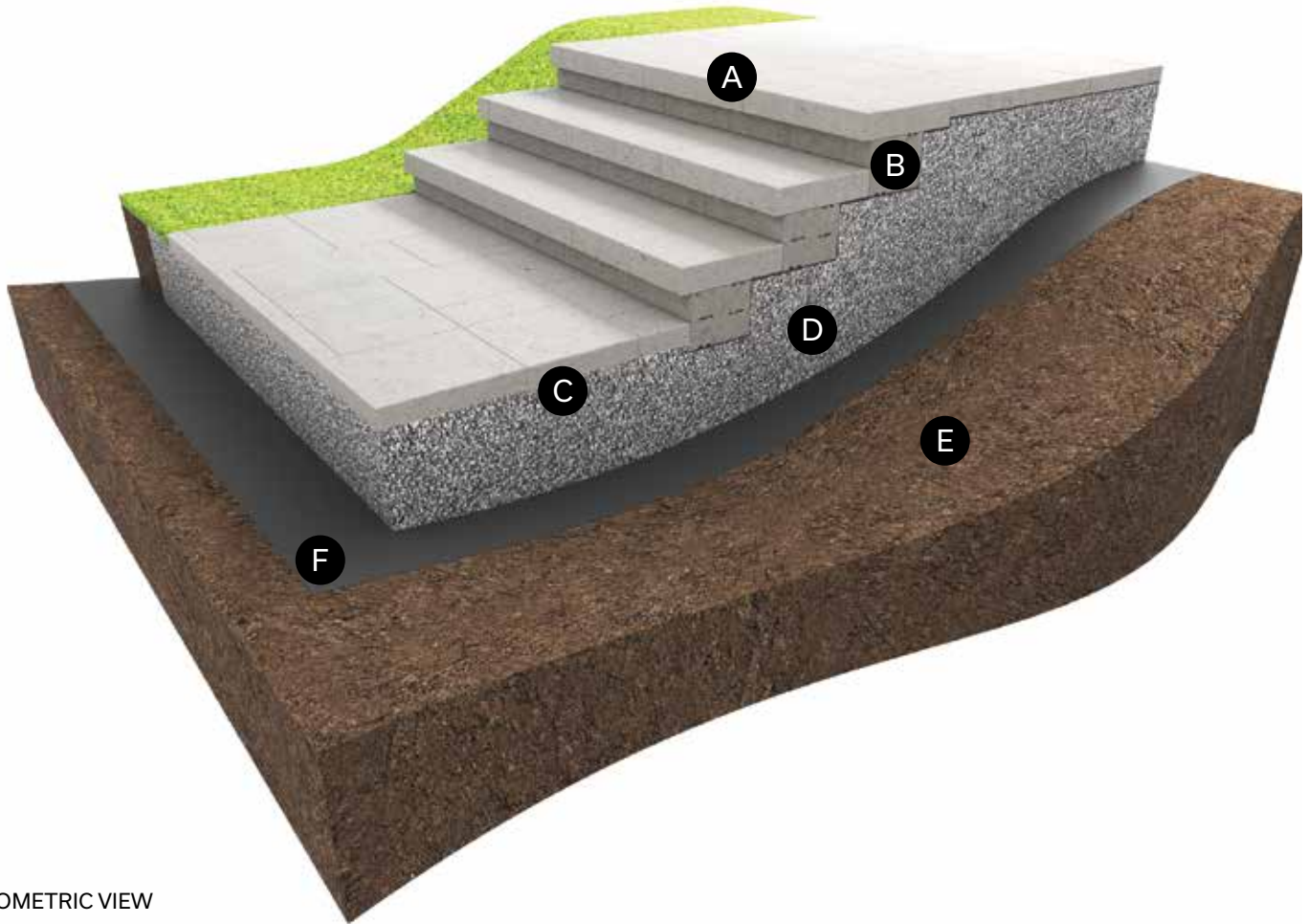

ISOMETRIC VIEW

- A** Melville Plus 90 Step
- B** Vario Wall 90 mm
- C** Laying bed: 25 mm - 1 in.
- D** Compacted granular foundation:
0 to 20 mm - 0 to 3/4 in.
Depth: 300 mm - 12 in. minimum
- E** Undisturbed soil
- F** Geotextile membrane

CROSS-SECTION - WALL STEP INSTALLATION

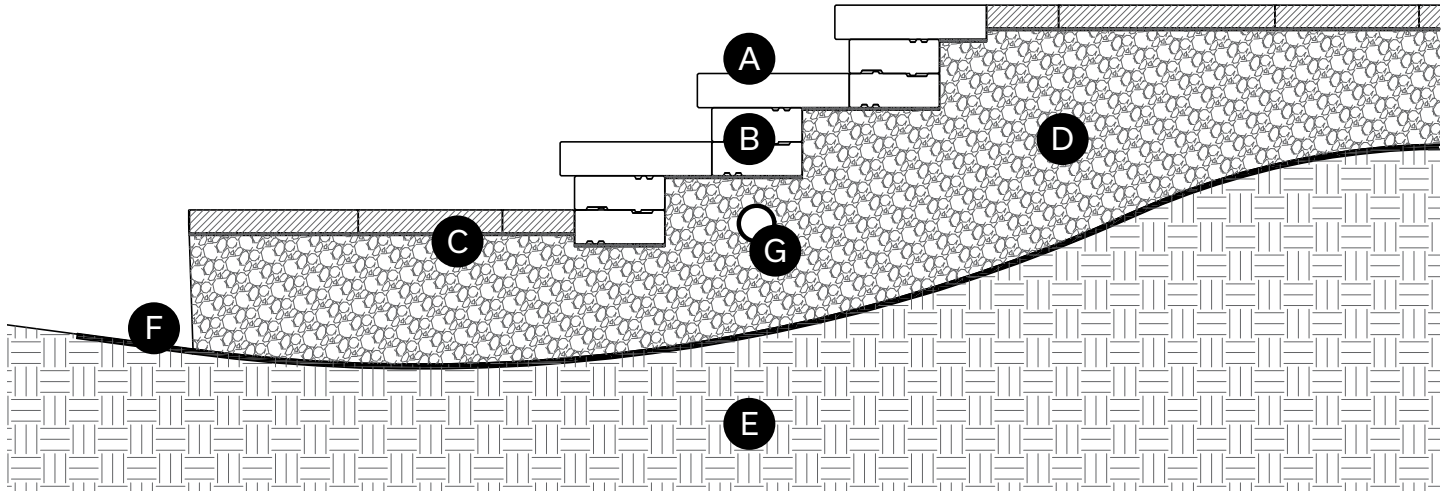

- Ⓐ Melville Plus 90 Step
- Ⓑ Vario Wall 90 mm
- Ⓒ Laying bed: 25 mm - 1 in.
- Ⓓ Compacted granular foundation:
0 to 20 mm - 0 to 3/4 in.
Depth: 300 mm - 12 in. minimum
- Ⓔ Undisturbed soil
- Ⓕ Geotextile membrane
- Ⓖ Perforated drain connected to services:
100 mm Ø - 4 in.

12 ROW SETBACK WALL – WITH SURCHARGE, NO SLOPE

Vario Wall 90 mm installed with a setback and geogrid – 12 rows (total height of 1080 mm or 42 in.). With surcharge behind the wall (5kPa), no slope.

- > Install Vario Wall 90 mm units in pairs: create a 30 mm setback by following the tongue and groove system on every other row
- > Create the setback by installing the outer groove (female) on the tongue (male) at every other row
- > Always position the tongue on the outer side of the wall
- > Add a 1250 mm long geogrid (50 in.) over the Vario Wall unit. The geogrid is held by the tongue and groove system and the weight of the clean stone. Recommended geogrid: Miragrid 2XT
- > At the very last row, turn the unit upside down to have the tongue downward. Then, use Techniseal concrete adhesive to glue the Permacon capping of your choice.

No accessory required for the Vario Wall. You don't have to use concrete adhesive between each row of the Vario Wall.

Maximum gravity wall heights assume no slopes or surcharge behind the wall and that the wall retains sand or gravel ($\phi = 34$ degrees, $\gamma = 19$ kN/m³)²

12 ROW SETBACK WALL - WITH SURCHARGE, NO SLOPE

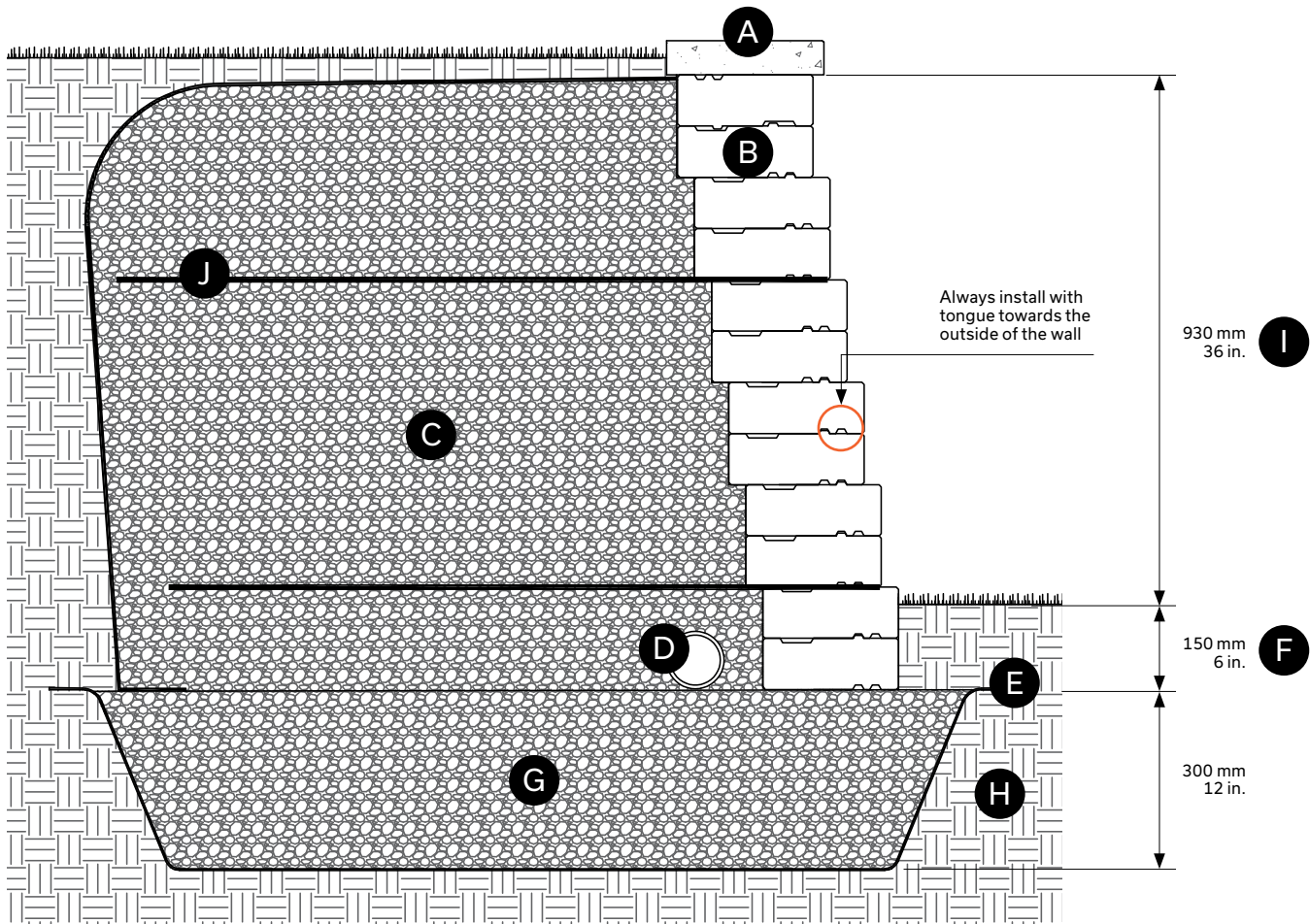

- A** Capping
- B** Vario Wall 90 mm (setback angle: 9.46 degrees, 150 mm)
- C** Clean stone 20 mm - 3/4 in. - Depth: 1400 mm - 55 in. min.
- D** Perforated drain connected to services: 100 mm Ø - 4 in.
- E** Geotextile membrane
- F** Minimum buried depth 150 mm - 6 in.
- G** Compacted granular foundation: 0 to 20 mm - 0 to 3/4 in. - Depth: 300 mm - 12 in. minimum
- H** Undisturbed soil
- I** Maximum height with surcharge and no slope behind the wall, excluding the buried units and capping
- J** Geogrid 1250 mm - 50 in.

18 ROW SETBACK WALL – WITH SURCHARGE, NO SLOPE

Vario Wall 90 mm installed with a setback and geogrid – 18 rows (total height of 1620 mm or 63 in.). With surcharge behind the wall (5kPa), no slope.

- > Install Vario Wall 90 mm units in pairs: create a 30 mm setback by following the tongue and groove system on every other row
- > Create the setback by installing the outer groove (female) on the tongue (male) at every other row
- > Always position the tongue on the outer side of the wall
- > Add a 1250 mm long geogrid (50 in.) over the Vario Wall unit. The geogrid is held by the tongue and groove system and the weight of the clean stone. Recommended geogrid: Miragrid 2XT
- > At the very last row, turn the unit upside down to have the tongue downward. Then, use Techniseal concrete adhesive to glue the Permacon capping of your choice.

No accessory required for the Vario Wall. You don't have to use concrete adhesive between each row of the Vario Wall.

Maximum gravity wall heights assume no slopes or surcharge behind the wall and that the wall retains sand or gravel ($\phi = 34$ degrees, $\gamma = 19 \text{ kN/m}^3$)²

18 ROW SETBACK WALL - WITH SURCHARGE, NO SLOPE

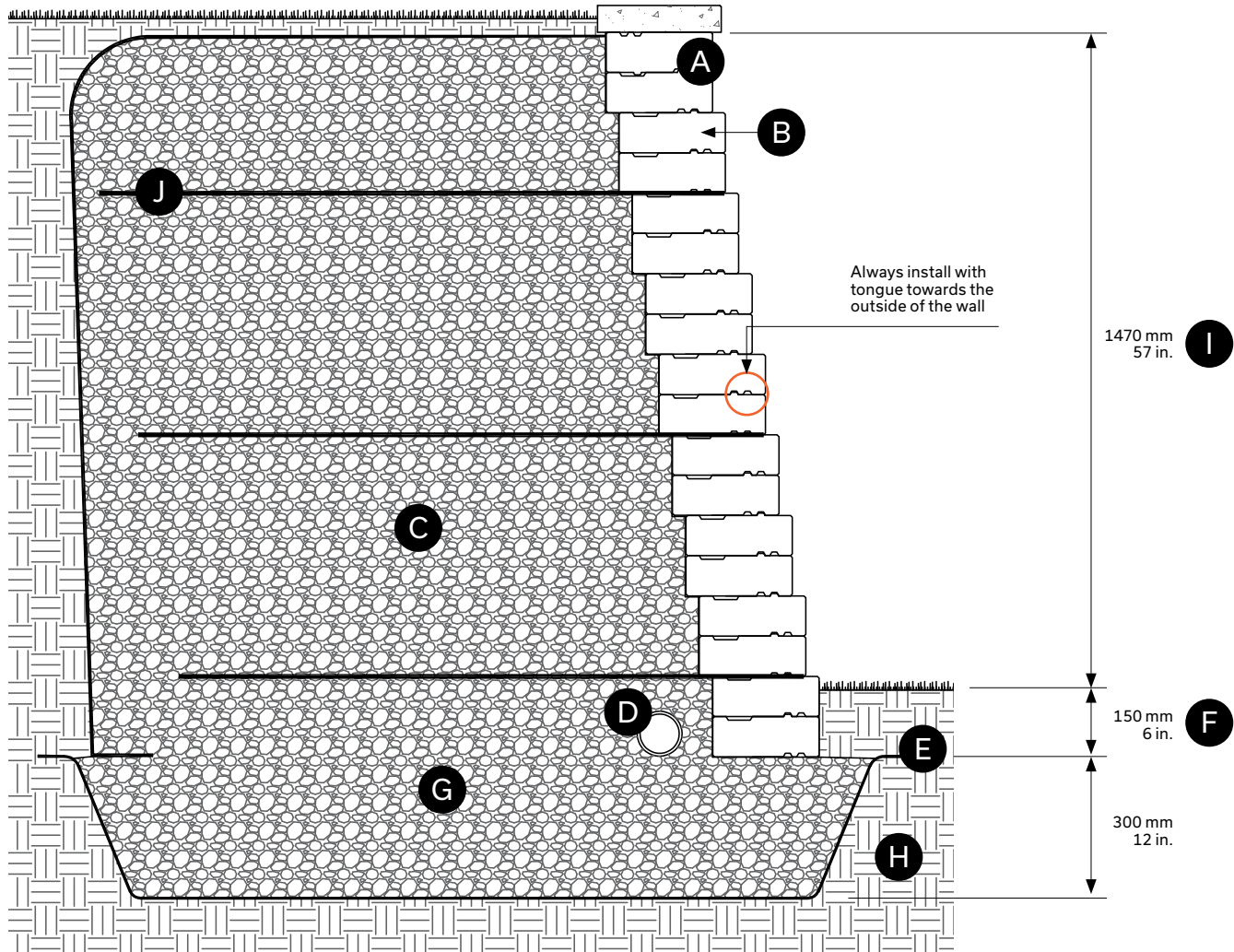

- A Capping
- B Vario Wall 90 mm (setback angle: 9.46 degrees, 240 mm)
- C Clean stone 20 mm - 3/4 in. - Depth: 1490 mm - 59 in. min.
- D Perforated drain connected to services: 100 mm Ø - 4 in.
- E Geotextile membrane
- F Minimum buried depth 150 mm - 6 in.
- G Compacted granular foundation: 0 to 20 mm - 0 to 3/4 in. - Depth: 300 mm - 12 in. minimum
- H Undisturbed soil
- I Maximum height with surcharge and no slope behind the wall, excluding the buried units and capping
- J Geogrid 1250 mm - 50 in.

24 ROW SETBACK WALL – WITH SURCHARGE, NO SLOPE

Vario Wall 90 mm installed with a setback and geogrid – 24 rows (total height of 2160 mm or 84 in.). With surcharge behind the wall (5kPa), no slope.

- > Install Vario Wall 90 mm units in pairs: create a 30 mm setback by following the tongue and groove system on every other row
- > Create the setback by installing the outer groove (female) on the tongue (male) at every other row
- > Always position the tongue on the outer side of the wall
- > Add a 1550 mm long geogrid (61 in.) over the Vario Wall unit. The geogrid is held by the tongue and groove system and the weight of the clean stone. Recommended geogrid: Miragrid 2XT
- > At the very last row, turn the unit upside down to have the tongue downward. Then, use Techniseal concrete adhesive to glue the Permacon capping of your choice.

No accessory required for the Vario Wall. You don't have to use concrete adhesive between each row of the Vario Wall.

Maximum gravity wall heights assume no slopes or surcharge behind the wall and that the wall retains sand or gravel ($\phi = 34$ degrees, $\gamma = 19$ kN/m³)²

24 ROW SETBACK WALL - WITH SURCHARGE, NO SLOPE

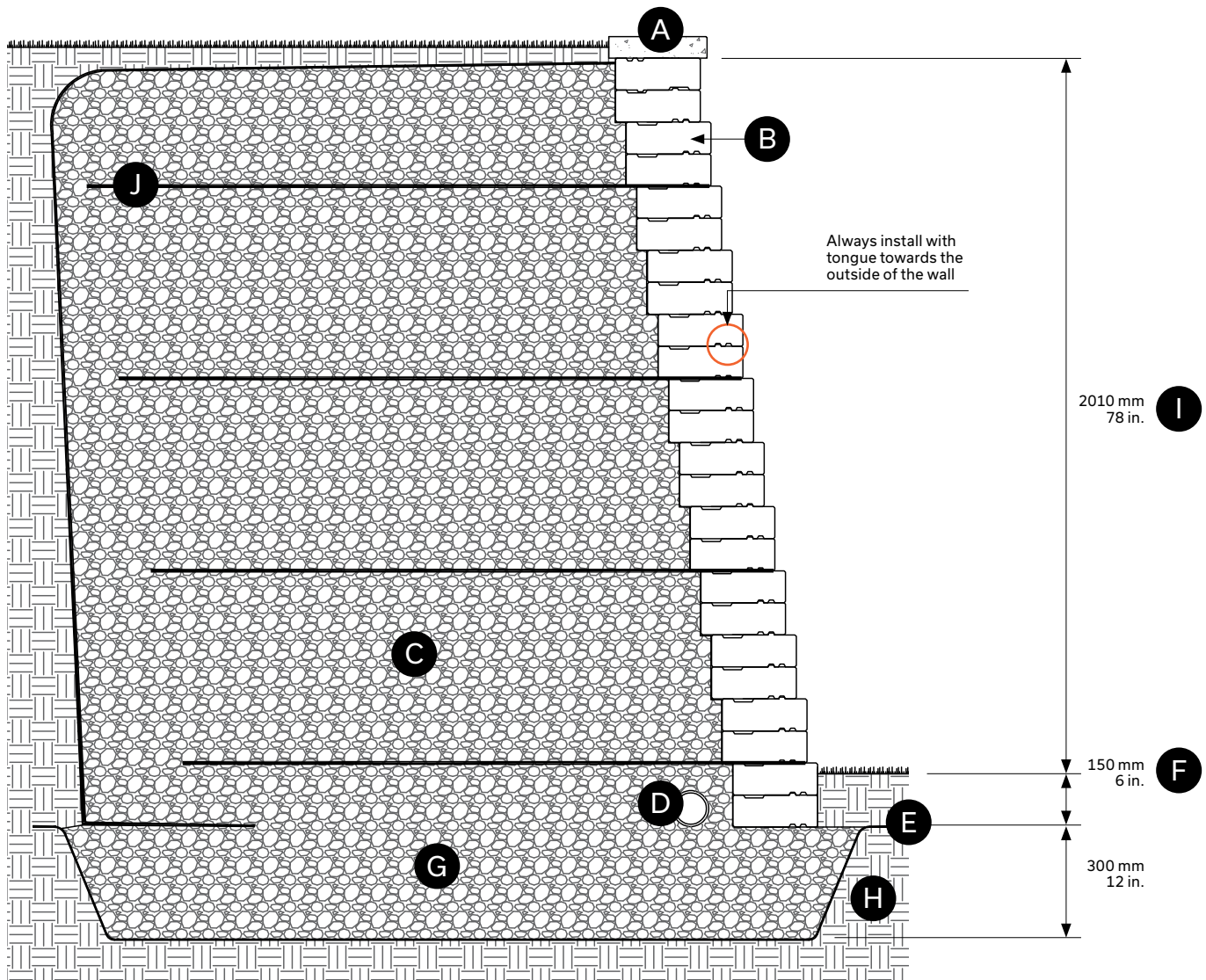

- (A) Capping
- (B) Vario Wall 90 mm (setback angle: 9.46 degrees, 330 mm)
- (C) Clean stone 20 mm - 3/4 in. - Depth: 1880 mm - 74 in. min.
- (D) Perforated drain connected to services: 100 mm Ø - 4 in.
- (E) Geotextile membrane
- (F) Minimum buried depth 150 mm - 6 in.
- (G) Compacted granular foundation: 0 to 20 mm - 0 to 3/4 in. - Depth: 300 mm - 12 in. minimum
- (H) Undisturbed soil
- (I) Maximum height with surcharge and no slope behind the wall, excluding the buried units and capping
- (J) Geogrid 1550 mm - 61 in.

30 ROW SETBACK WALL – WITH SURCHARGE, NO SLOPE

Vario Wall 90 mm installed with a setback and geogrid – 30 rows (total height of 2700 mm or 105 in.). With surcharge behind the wall (5kPa), no slope.

- > Install Vario Wall 90 mm units in pairs: create a 30 mm setback by following the tongue and groove system on every other row
- > Create the setback by installing the outer groove (female) on the tongue (male) at every other row
- > Always position the tongue on the outer side of the wall
- > Add a 1885 mm long geogrid (74 in.) over the Vario Wall unit. The geogrid is held by the tongue and groove system and the weight of the clean stone. Recommended geogrid: Miragrid 2XT
- > At the very last row, turn the unit upside down to have the tongue downward. Then, use Techniseal concrete adhesive to glue the Permacon capping of your choice.

No accessory required for the Vario Wall. You don't have to use concrete adhesive between each row of the Vario Wall.

Maximum gravity wall heights assume no slopes or surcharge behind the wall and that the wall retains sand or gravel ($\phi = 34$ degrees, $\gamma = 19 \text{ kN/m}^3$)²

30 ROW SETBACK WALL - WITH SURCHARGE, NO SLOPE

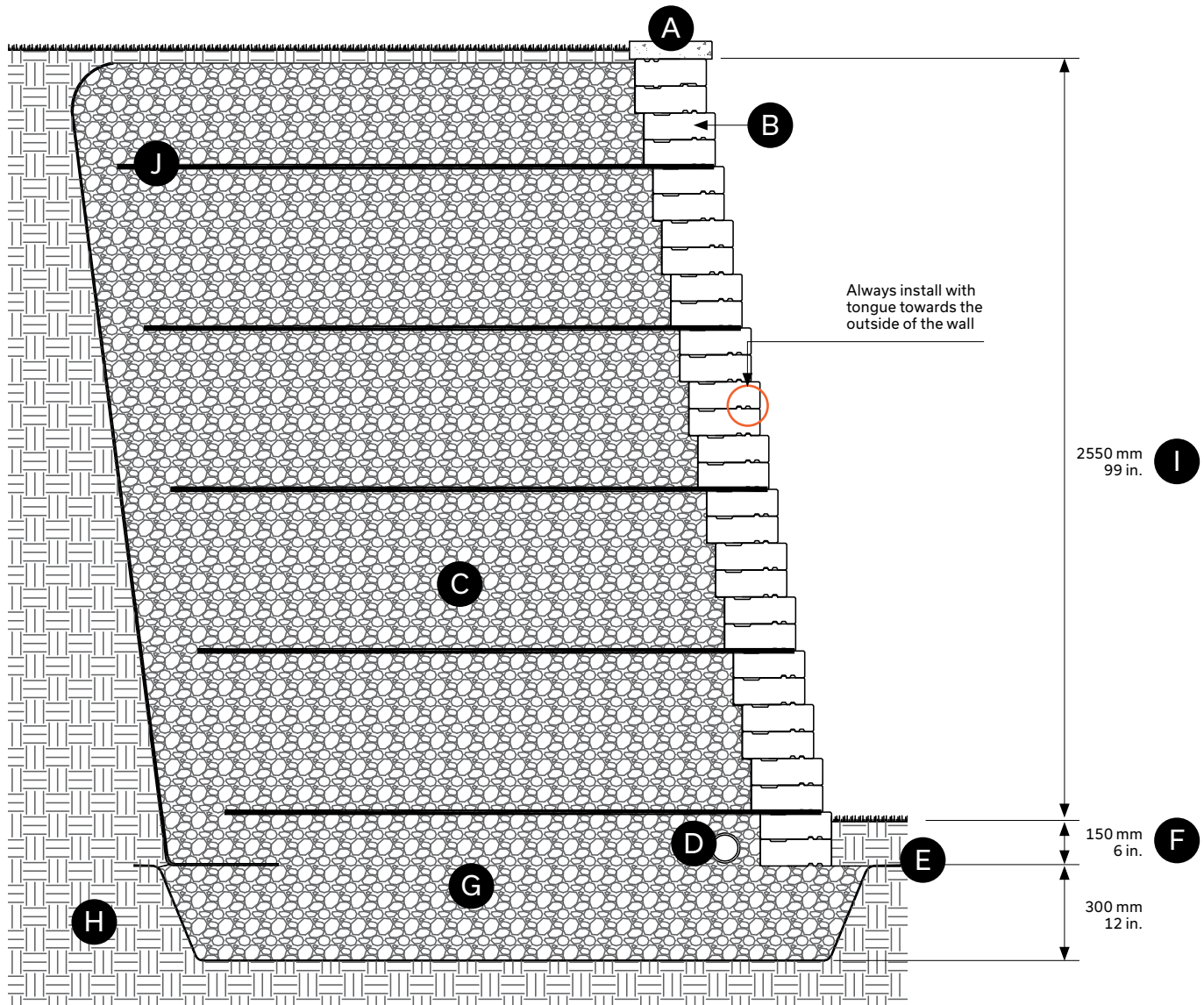

- (A) Capping
- (B) Vario Wall 90 mm (setback angle: 9.46 degrees, 420 mm)
- (C) Clean stone 20 mm - 3/4 in. - Depth: 2270 mm - 89 in. min.
- (D) Perforated drain connected to services: 100 mm Ø - 4 in.
- (E) Geotextile membrane
- (F) Minimum buried depth 150 mm - 6 in.
- (G) Compacted granular foundation: 0 to 20 mm - 0 to 3/4 in. - Depth: 300 mm - 12 in. minimum
- (H) Undisturbed soil
- (I) Maximum height with surcharge and no slope behind the wall, excluding the buried units and capping
- (J) Geogrid 1885 mm - 74 in.

12 ROW VERTICAL WALL – WITH SURCHARGE, NO SLOPE

Vario Wall 90 mm installed in a vertical application with geogrid – 12 rows (total height of 1080 mm or 42 in). With surcharge (5 kPa), no slope.

- > Always position the tongue on the outer side of the wall
- > Add a 1250 mm long geogrid (50 in.) over the Vario Wall unit. The geogrid is held by the tongue and groove system and the weight of the clean stone. Recommended geogrid: Miragrid 2XT
- > At the very last row, turn the unit upside down to have the tongue downward. Then, use Techniseal concrete adhesive to glue the Permacon capping of your choice.

No accessory required for the Vario Wall. You don't have to use concrete adhesive between each row of the Vario Wall.

Maximum gravity wall heights assume no slopes or surcharge behind the wall and that the wall retains sand or gravel ($\phi = 34$ degrees, $\gamma = 19$ kN/m³)²

12 ROW VERTICAL WALL - WITH SURCHARGE, NO SLOPE

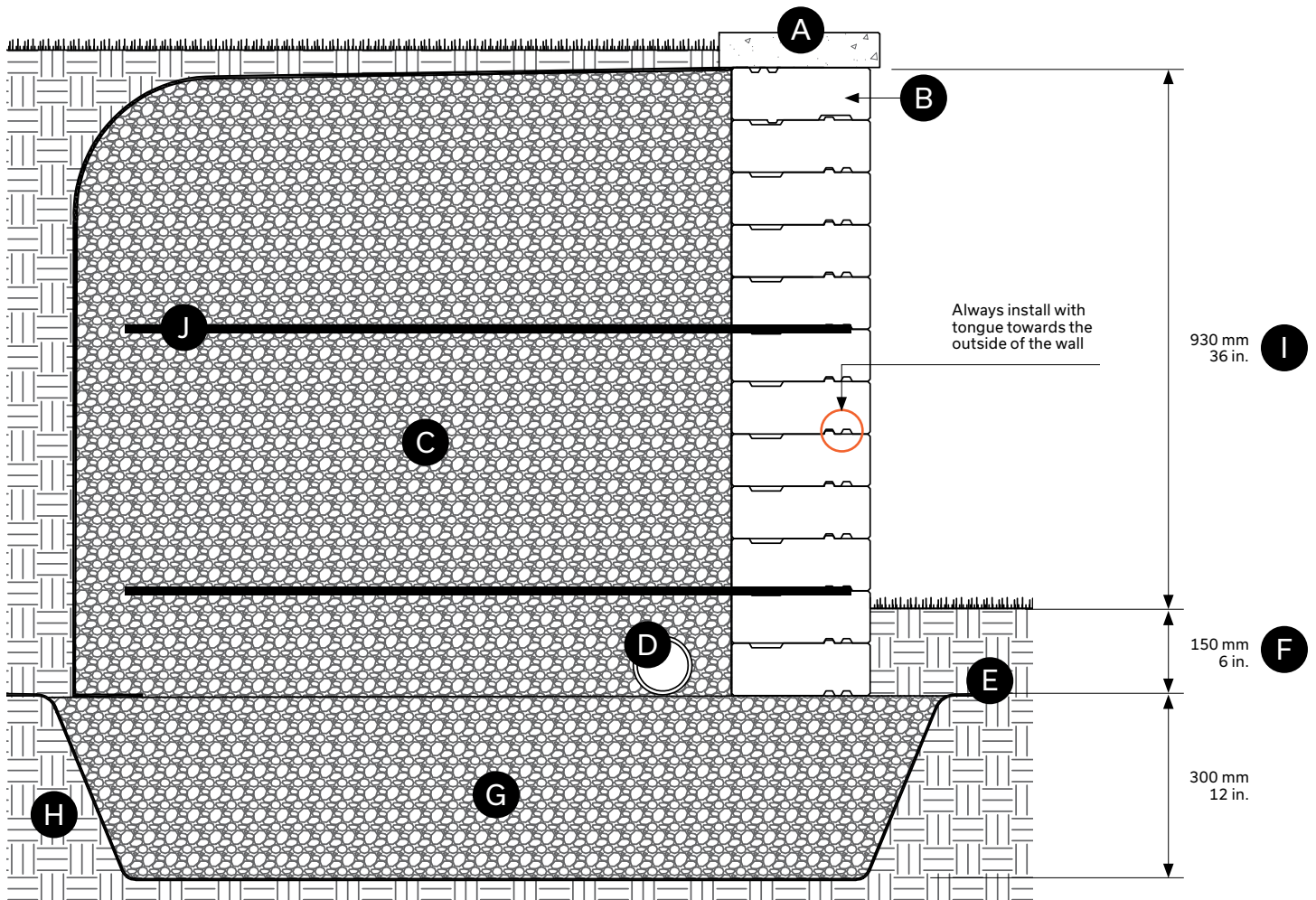

- A** Capping
- B** Vario Wall 90 mm
- C** Clean stone 20 mm - 3/4 in. - Depth: 1400 mm - 55 in. min.
- D** Perforated drain connected to services: 100 mm Ø - 4 in.
- E** Geotextile membrane
- F** Minimum buried depth 150 mm - 6 in.
- G** Compacted granular foundation: 0 to 20 mm - 0 to 3/4 in. - Depth: 300 mm - 12 in. minimum
- H** Undisturbed soil
- I** Maximum height with surcharge and no slope behind the wall, excluding the buried units and capping
- J** Geogrid 1250 mm - 50 in.

18 ROW VERTICAL WALL – WITH SURCHARGE, NO SLOPE

Vario Wall 90 mm installed in a vertical application with geogrid – 18 rows (total height of 1620 mm or 63 in). With surcharge (5 kPa), no slope.

- > Always position the tongue on the outer side of the wall
- > Add a 1250 mm long geogrid (50 in.) over the Vario Wall unit. The geogrid is held by the tongue and groove system and the weight of the clean stone. Recommended geogrid: Miragrid 2XT
- > At the very last row, turn the unit upside down to have the tongue downward. Then, use Techniseal concrete adhesive to glue the Permacon capping of your choice.

No accessory required for the Vario Wall. You don't have to use concrete adhesive between each row of the Vario Wall.

Maximum gravity wall heights assume no slopes or surcharge behind the wall and that the wall retains sand or gravel ($\phi = 34$ degrees, $\gamma = 19$ kN/m³)²

18 ROW VERTICAL WALL - WITH SURCHARGE, NO SLOPE

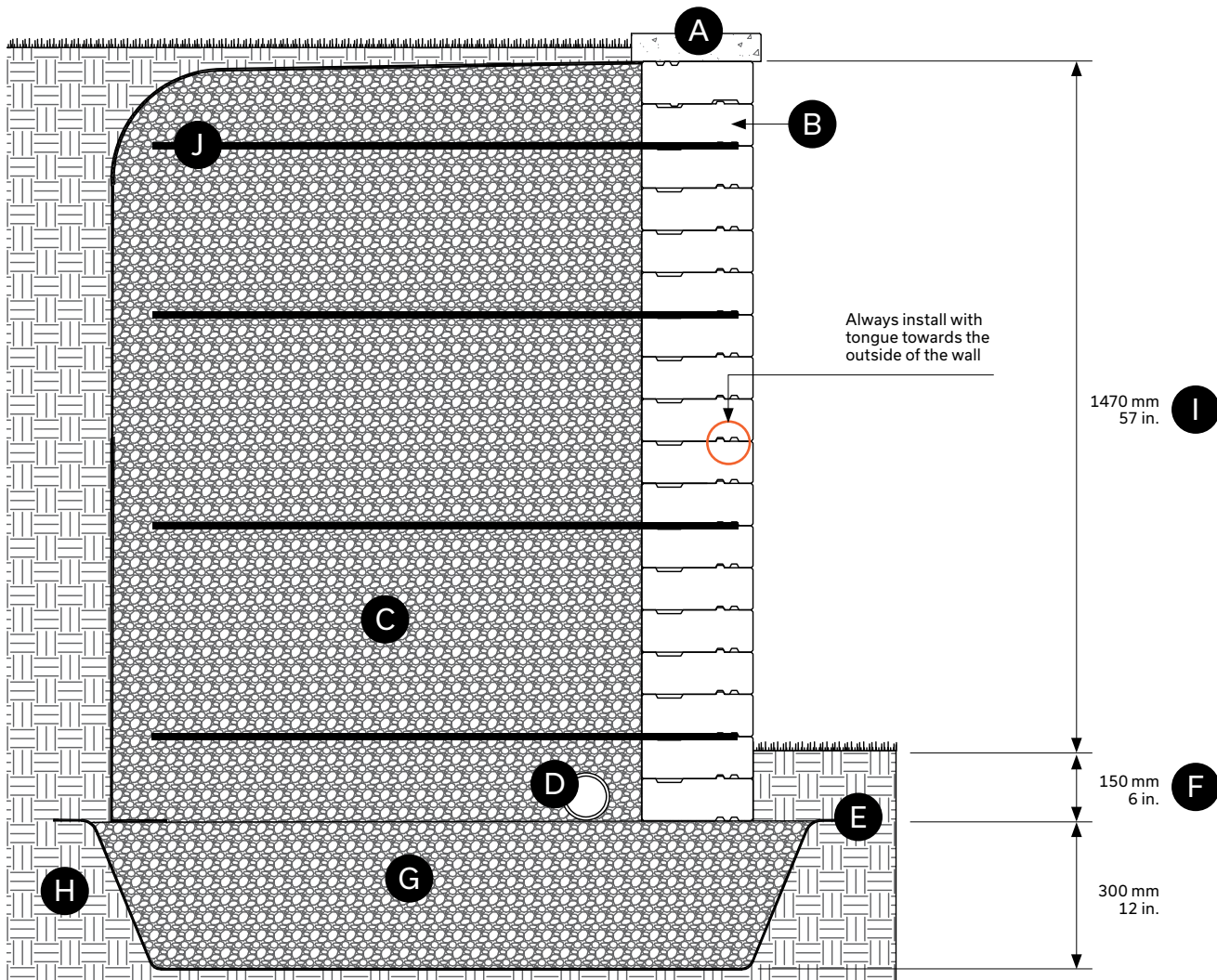

- (A) Capping
- (B) Vario Wall 90 mm
- (C) Clean stone 20 mm - 3/4 in. - Depth: 1490 mm - 59 in. min.
- (D) Perforated drain connected to services: 100 mm Ø - 4 in.
- (E) Geotextile membrane
- (F) Minimum buried depth 150 mm - 6 in.
- (G) Compacted granular foundation: 0 to 20 mm - 0 to 3/4 in. - Depth: 300 mm - 12 in. minimum
- (H) Undisturbed soil
- (I) Maximum height with surcharge and no slope behind the wall, excluding the buried units and capping
- (J) Geogrid 1250 mm - 50 in.

24 ROW VERTICAL WALL – WITH SURCHARGE, NO SLOPE

Vario Wall 90 mm installed in a vertical application with geogrid
– 24 rows (total height of 2160 mm or 84 in). With surcharge (5
kPa), no slope.

- > Always position the tongue on the outer side of the wall
- > Add a 1550 mm long geogrid (61 in.) over the Vario Wall unit. The geogrid is held by the tongue and groove system and the weight of the clean stone. Recommended geogrid: Miragrid 2XT
- > At the very last row, turn the unit upside down to have the tongue downward. Then, use Techniseal concrete adhesive to glue the Permacon capping of your choice.

No accessory required for the Vario Wall. You don't have to use concrete adhesive between each row of the Vario Wall.

Maximum gravity wall heights assume no slopes or surcharge behind the wall and that the wall retains sand or gravel ($\phi = 34$ degrees, $\gamma = 19$ kN/m³)²

24 ROW VERTICAL WALL - WITH SURCHARGE, NO SLOPE

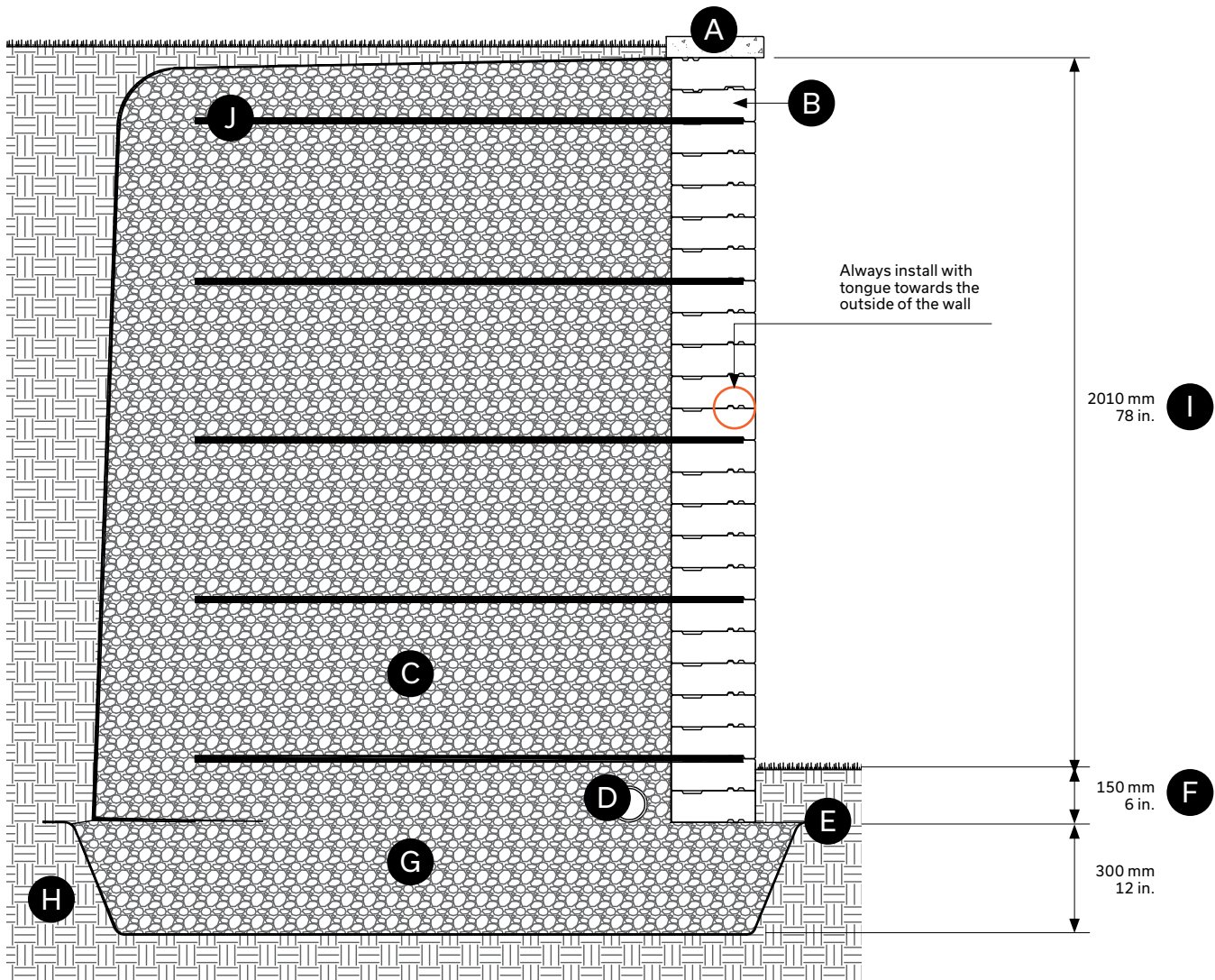

- A** Capping
- B** Vario Wall 90 mm
- C** Clean stone 20 mm - 3/4 in. - Depth: 1880 mm - 74 in. min.
- D** Perforated drain connected to services: 100 mm Ø - 4 in.
- E** Geotextile membrane
- F** Minimum buried depth 150 mm - 6 in.
- G** Compacted granular foundation: 0 to 20 mm - 0 to 3/4 in. - Depth: 300 mm - 12 in. minimum
- H** Undisturbed soil
- I** Maximum height with surcharge and no slope behind the wall, excluding the buried units and capping
- J** Geogrid 1550 mm - 61 in.

30 ROW VERTICAL WALL – WITH SURCHARGE, NO SLOPE

Vario Wall 90 mm installed in a vertical application with geogrid
– 30 rows (total height of 2700 mm or 105 in). With surcharge
(5 kPa), no slope.

- > Always position the tongue on the outer side of the wall
- > Add a 1885 mm long geogrid (74 in.) over the Vario Wall unit.
The geogrid is held by the tongue and groove system and the weight of the clean stone. Recommended geogrid: Miragrid 2XT
- > At the very last row, turn the unit upside down to have the tongue downward. Then, use Techniseal concrete adhesive to glue the Permacon capping of your choice.

No accessory required for the Vario Wall. You don't have to use concrete adhesive between each row of the Vario Wall.

Maximum gravity wall heights assume no slopes or surcharge behind the wall and that the wall retains sand or gravel ($\phi = 34$ degrees, $\gamma = 19$ kN/m³)²

30 ROW VERTICAL WALL - WITH SURCHARGE, NO SLOPE

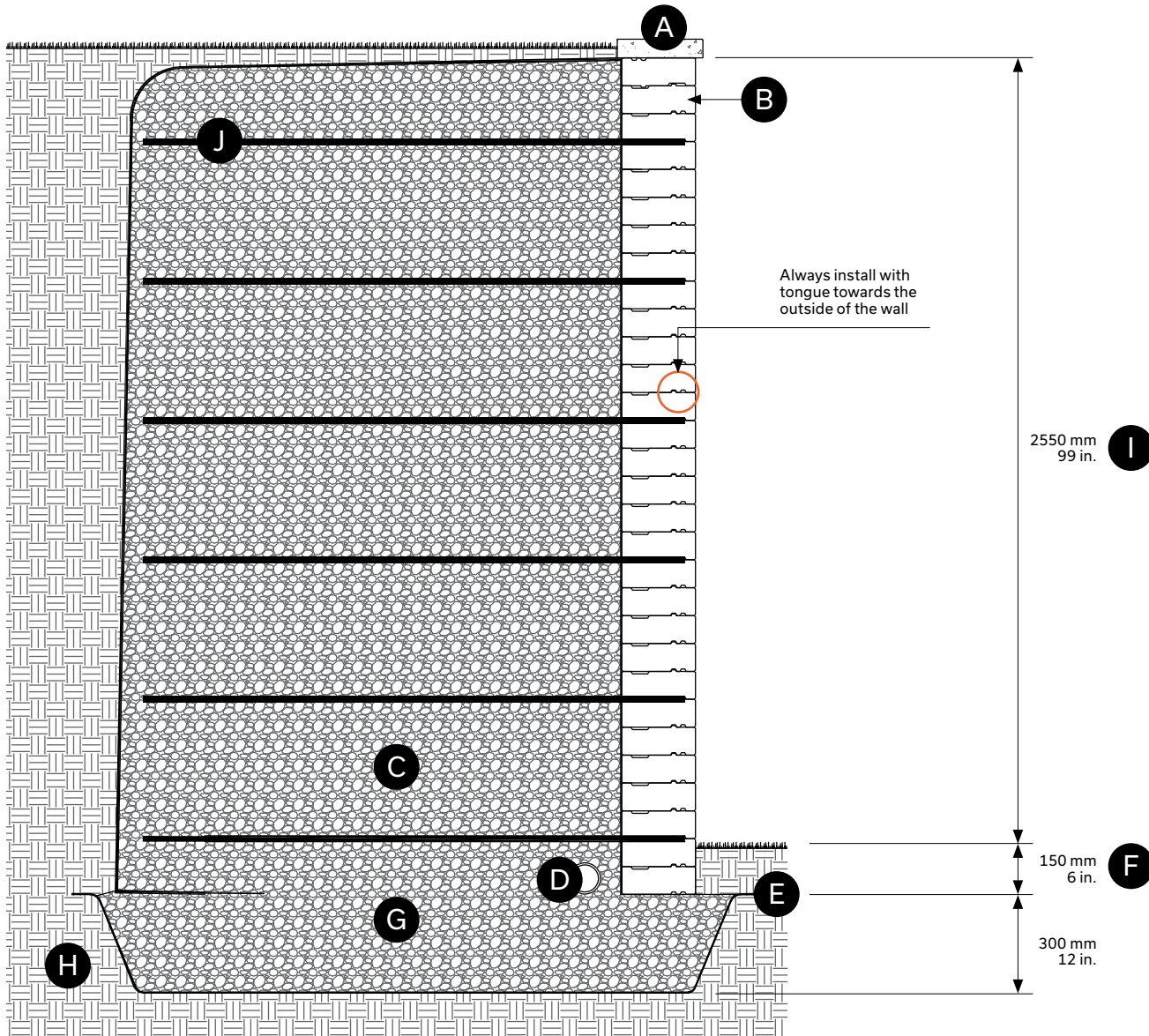

- A Capping
- B Vario Wall 90 mm
- C Clean stone 20 mm - 3/4 in. - Depth: 2270 mm - 89 in. min.
- D Perforated drain connected to services: 100 mm Ø - 4 in.
- E Geotextile membrane
- F Minimum buried depth 150 mm - 6 in.
- G Compacted granular foundation: 0 to 20 mm - 0 to 3/4 in. - Depth: 300 mm - 12 in. minimum
- H Undisturbed soil
- I Maximum height with surcharge and no slope behind the wall, excluding the buried units and capping
- J Geogrid 1885 mm - 74 in.

180 mm UNITS

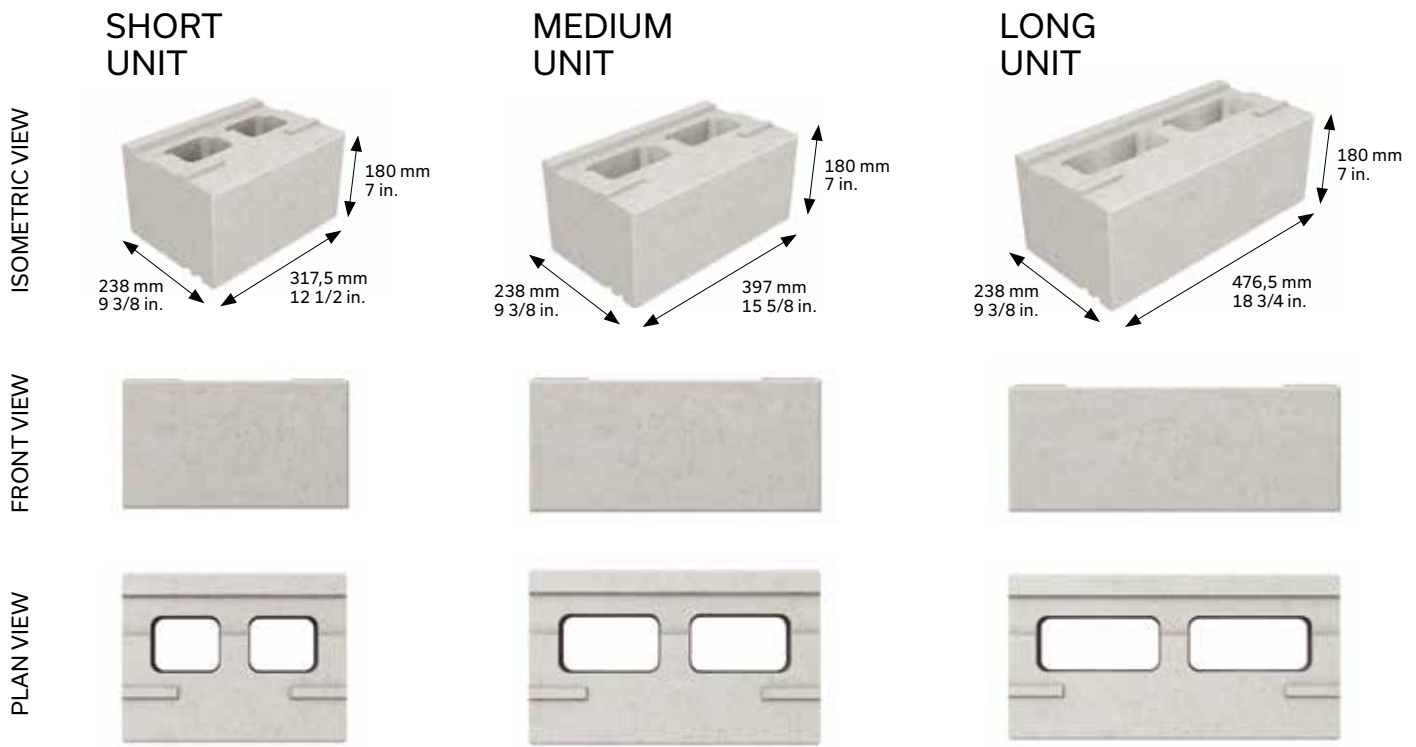

Note that Short, Medium and Long units are packaged on the same cube.

180 mm RIGHT CORNER UNITS

Only Long and Medium units are available as corners. On corner units, the groove does not run the full length and there's only one cavity.

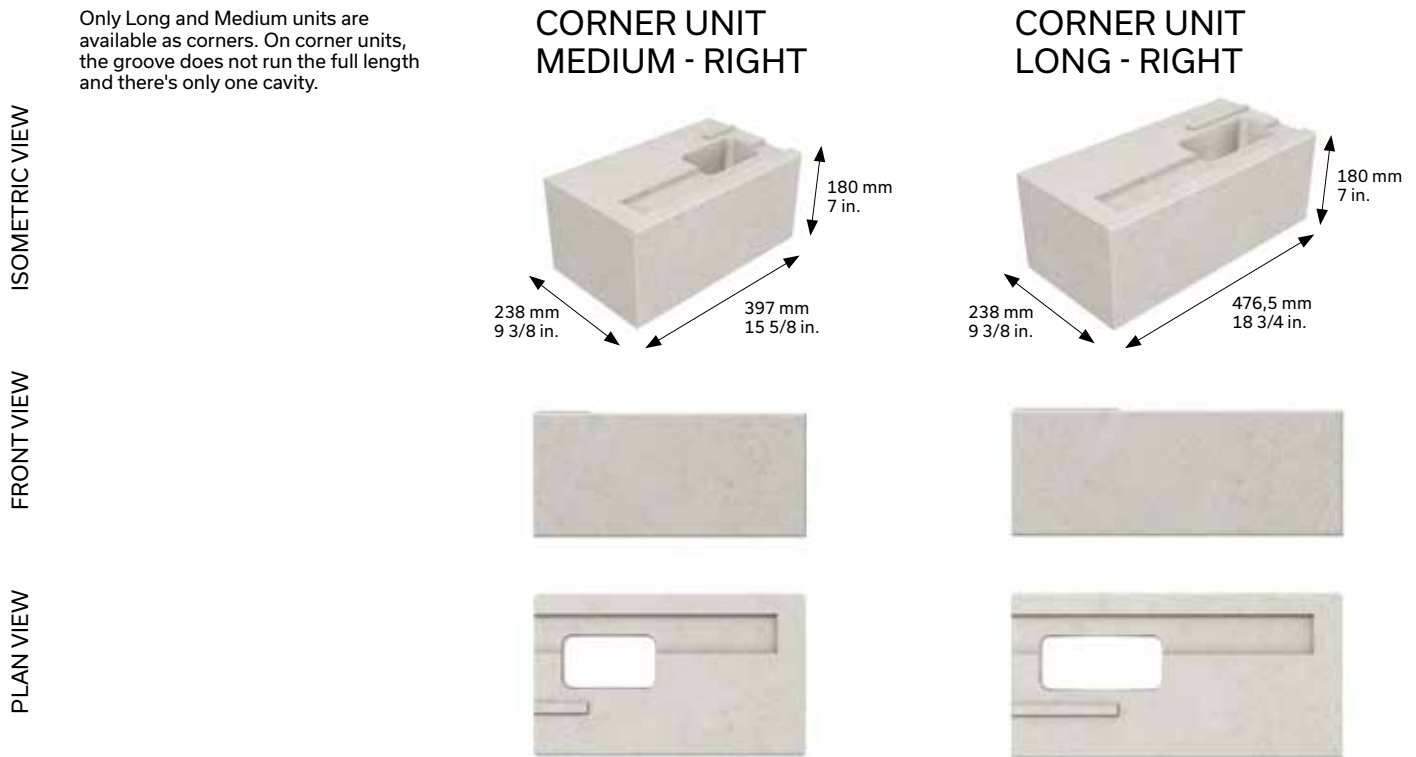

180 mm LEFT CORNER UNITS

Only Long and Medium units are available as corners. On corner units, the groove does not run the full length and there's only one cavity.

CORNER UNIT MEDIUM - LEFT

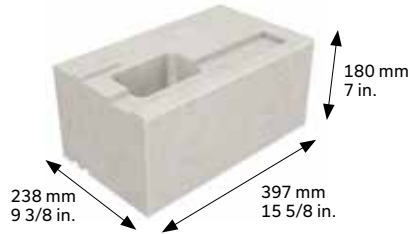

CORNER UNIT LONG - LEFT

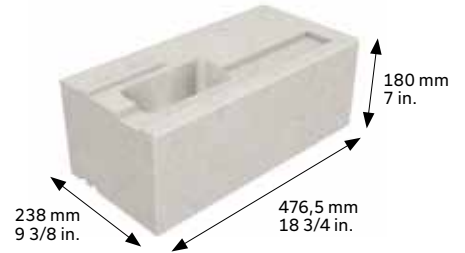

ISOMETRIC VIEW

FRONT VIEW



PLAN VIEW



BASIC PRINCIPLES

180 mm medium left corner unit

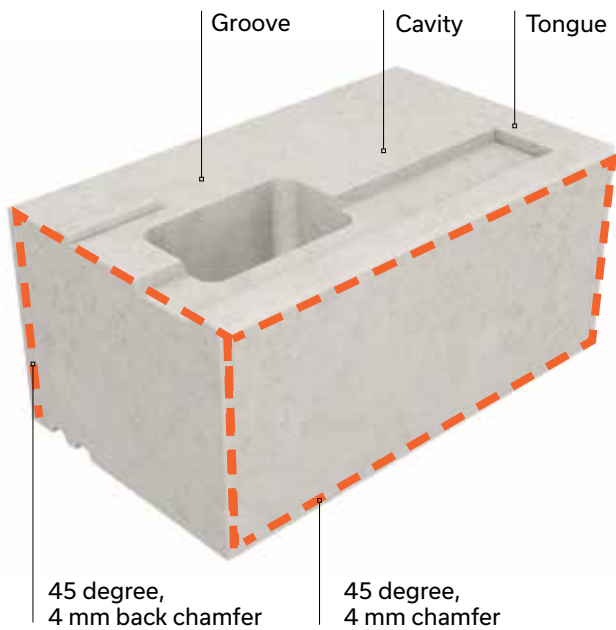

180 mm medium underside unit

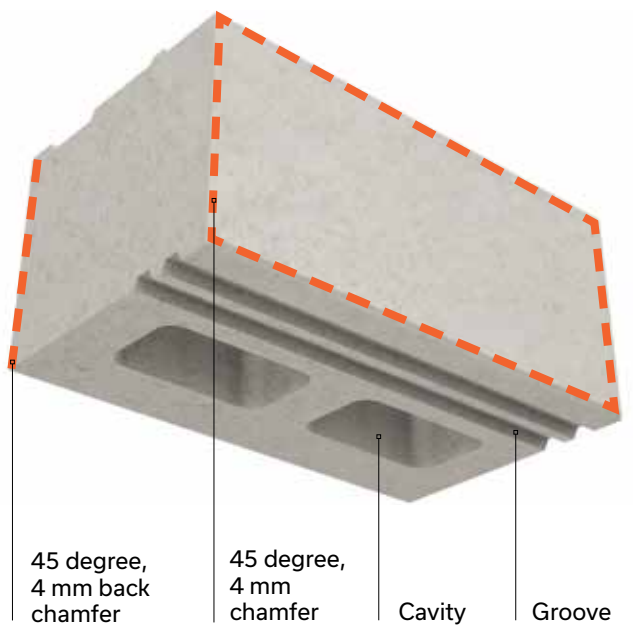

TYPICAL ROW

4 integrated corners per row: 1 right long, 1 right medium, 1 left long, 1 left medium

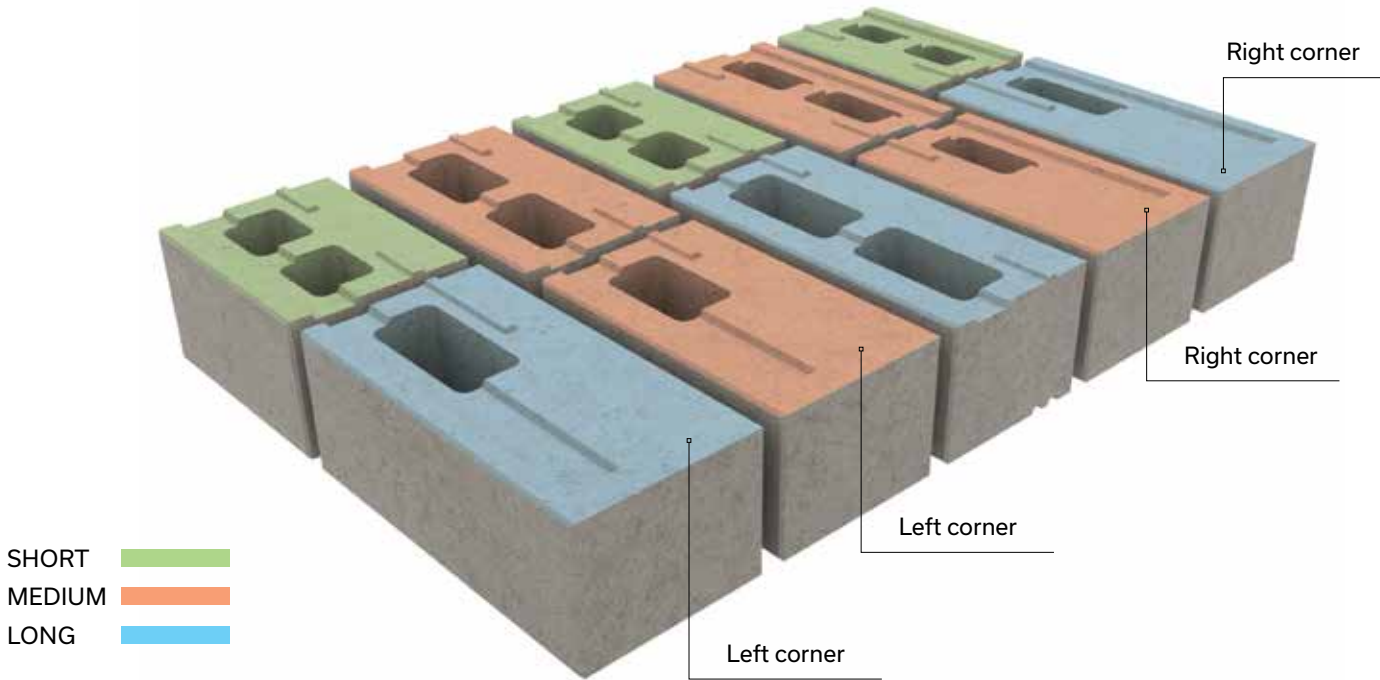

LAYING PATTERNS

LINEAR PATTERN - 100% VARIO 90

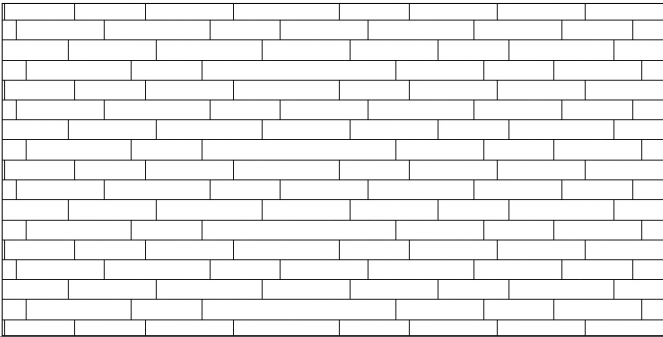

LINEAR PATTERN - 100% VARIO 180

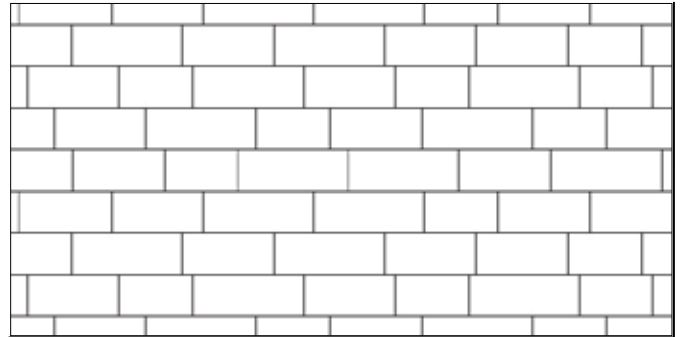

MODULAR PATTERN - 50% VARIO 90 AND 50% VARIO 180

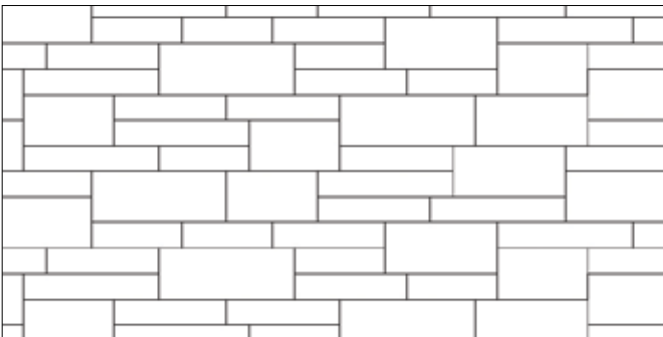

CROSS-SECTION - SETBACK WALL

Vario Wall 180 mm installed with a setback (30 mm per row) can go up to 4 row (total height of 720 mm or 28 in.)

- > Create the setback by installing the outer groove (female) on the tongue (male) at every row
- > Always have the cavities on the inside of the wall
- > You don't have to fill the cavities with clean stone in a standard installation
- > At the very last row, turn the unit upside down to have the tongues downward. Then, use Techniseal concrete adhesive to glue the capping unit of your choice.

No accessory required for the Vario Wall. You don't have to use concrete adhesive between each row of the Vario Wall.

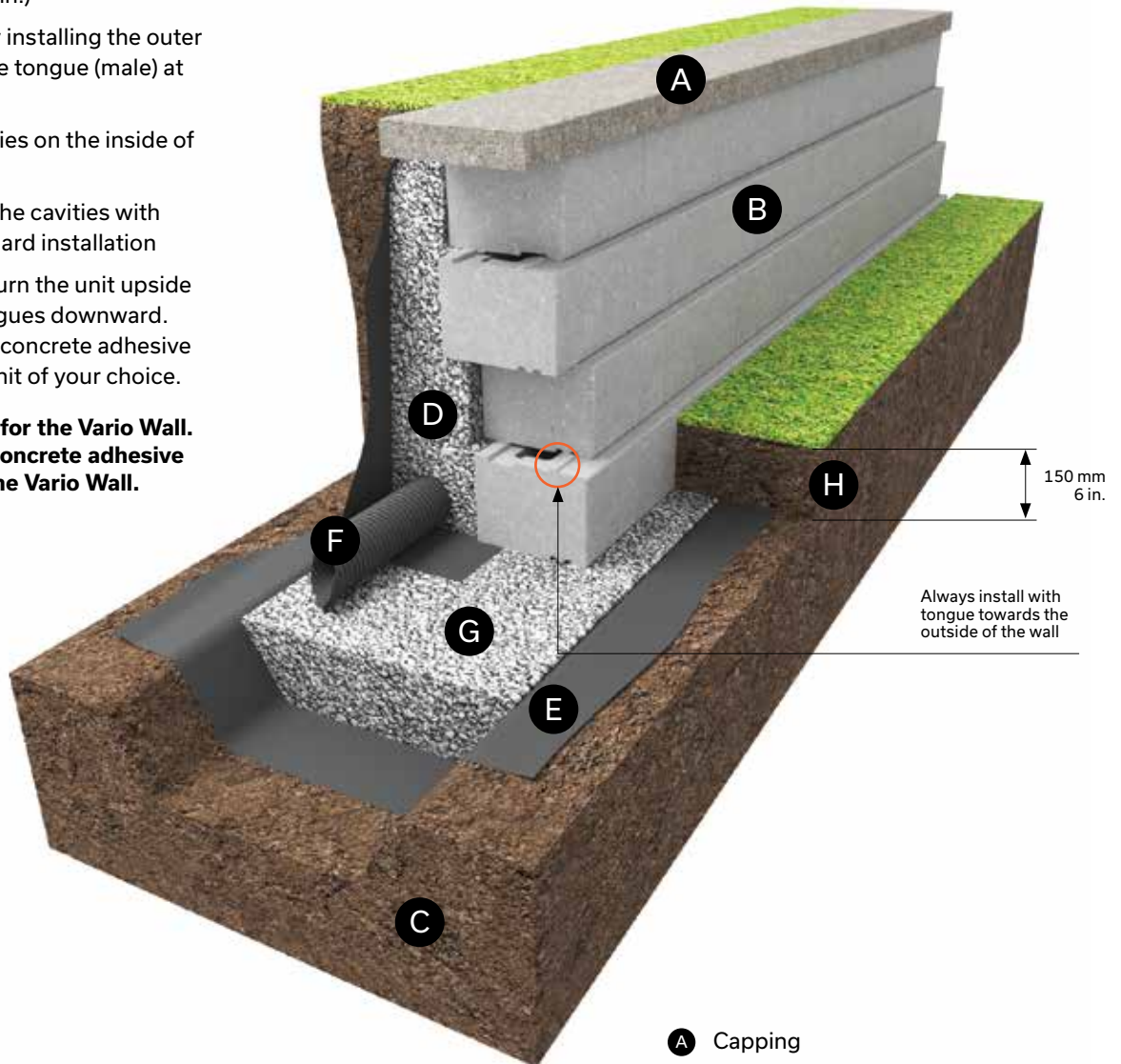

ISOMETRIC VIEW

- Ⓐ Capping
- Ⓑ Vario Wall 180 mm
- Ⓒ Undisturbed soil
- Ⓓ Clean stone 20 mm - 3/4 in. - Depth: 300 mm - 12 in. minimum
- Ⓔ Geotextile membrane
- Ⓕ Perforated drain connected to services: 100 mm Ø - 4 in.
- Ⓖ Compacted granular foundation: 0 to 20 mm - 0 to 3/4 in. Depth: 300 mm - 12 in. minimum
- Ⓗ Minimum buried depth 150 mm - 6 in.

Maximum gravity wall heights assume no slopes or surcharge behind the wall and that the wall retains sand or gravel ($\phi = 34$ degrees, $\gamma = 19 \text{ kN/m}^3$)²

CROSS-SECTION - SETBACK GRAVITY WALL

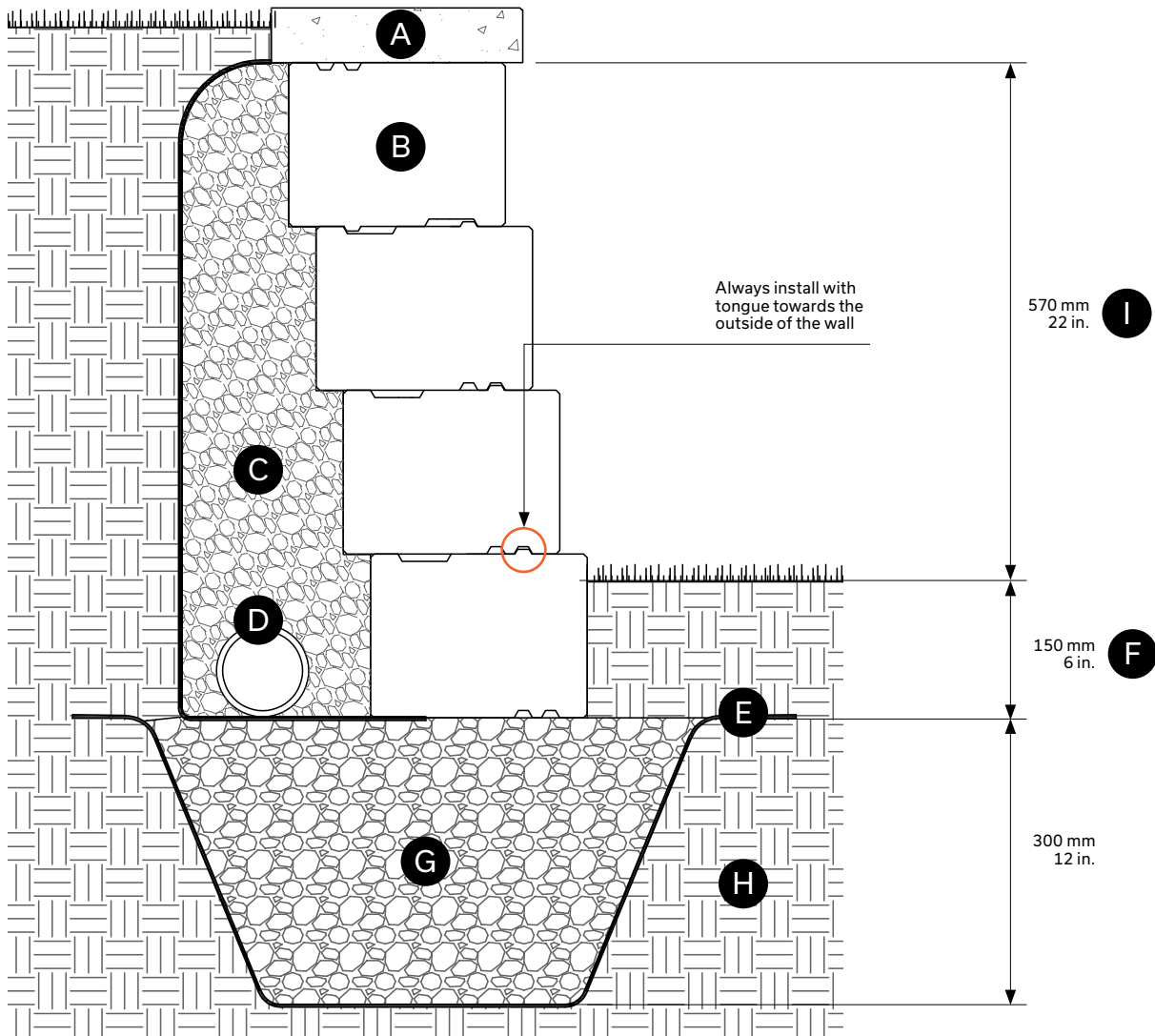

- A** Capping
- B** Vario Wall 180 mm
- C** Clean stone 20 mm - 3/4 in. - Depth: 300 mm - 12 in. min.
- D** Perforated drain connected to services: 100 mm Ø - 4 in.
- E** Geotextile membrane
- F** Minimum buried depth 150 mm - 6 in.
- G** Compacted granular foundation: 0 to 20 mm - 0 to 3/4 in. Depth: 300 mm - 12 in. minimum
- H** Undisturbed soil
- I** Maximum height with surcharge and no slope behind the wall, excluding the buried units and capping

Maximum gravity wall heights assume no slopes or surcharge behind the wall and that the wall retains sand or gravel ($\phi = 34$ degrees, $\gamma = 19 \text{ kN/m}^3$)²

VARIO WALL 180 mm

CROSS-SECTION - VERTICAL WALL

Vario Wall 180 mm installed in a vertical application can go up to 3 rows (total height of 540 mm or 21 in.).

- > Always have the cavities on the inside of the wall
- > You don't have to fill the cavities with clean stone in a standard installation
- > At the very last row, turn the unit upside down to have the tongues downward. Then, use Techniseal concrete adhesive to glue the capping unit of your choice.

No accessory required for the Vario Wall. You don't have to use concrete adhesive between each row of the Vario Wall.

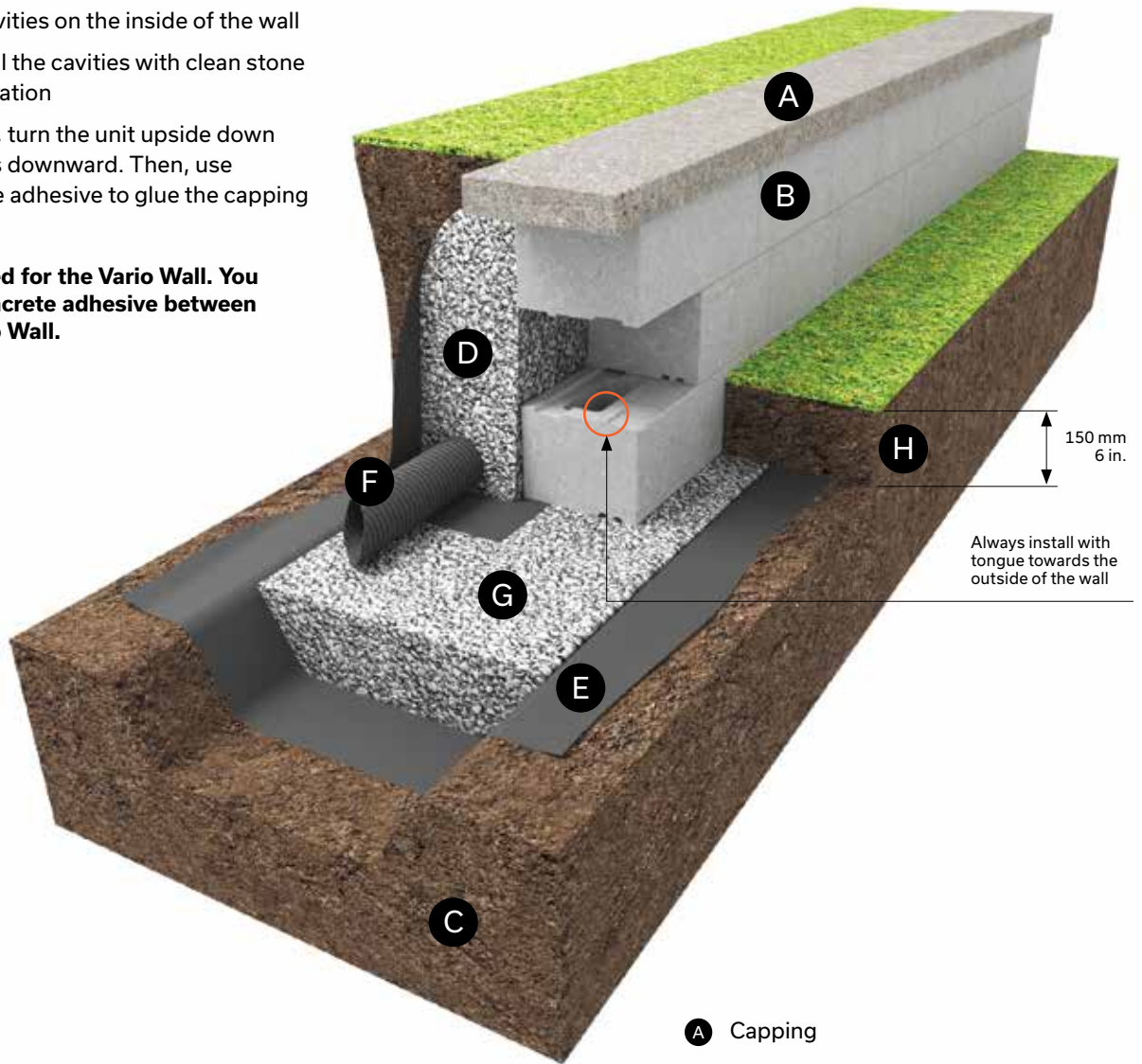

ISOMETRIC VIEW

- A** Capping
- B** Vario Wall 180 mm
- C** Undisturbed soil
- D** Clean stone 20 mm - 3/4 in. -
Depth: 300 mm - 12 in. minimum
- E** Geotextile membrane
- F** Perforated drain connected to services:
100 mm Ø - 4 in.
- G** Compacted granular foundation:
0 to 20 mm - 0 to 3/4 in.
Depth: 300 mm - 12 in. minimum
- H** Minimum buried depth 150 mm - 6 in.

Maximum gravity wall heights assume no slopes or surcharge behind the wall and that the wall retains sand or gravel ($\phi = 34$ degrees, $\gamma = 19$ kN/m³)²

CROSS-SECTION - VERTICAL GRAVITY WALL

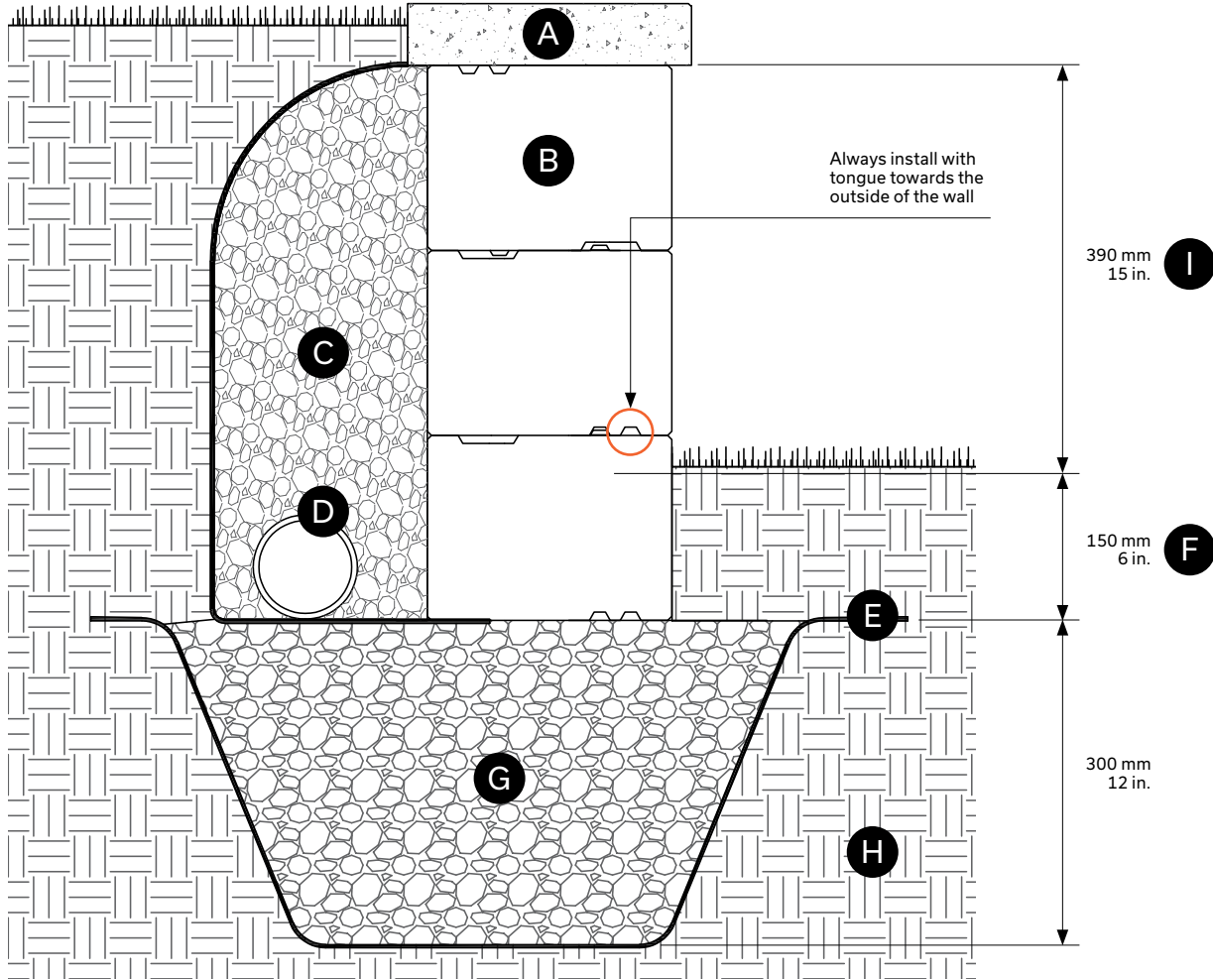

- (A) Capping
- (B) Vario Wall 180 mm
- (C) Clean stone 20 mm - 3/4 in. - Depth: 300 mm - 12 in. min.
- (D) Perforated drain connected to services: 100 mm Ø - 4 in.
- (E) Geotextile membrane
- (F) Minimum buried depth 150 mm - 6 in.
- (G) Compacted granular foundation: 0 to 20 mm - 0 to 3/4 in. Depth: 300 mm - 12 in. minimum
- (H) Undisturbed soil
- (I) Maximum height without surcharges or slopes behind the wall, excluding the buried units and capping

Maximum gravity wall heights assume no slopes or surcharge behind the wall and that the wall retains sand or gravel ($\phi = 34$ degrees, $\gamma = 19 \text{ kN/m}^3$)²

VARIO WALL 180 mm

CROSS-SECTION - DOUBLE-SIDED WALL

Vario Wall 180 mm installed in a double-sided application can go up to 5 rows (total height of 900 mm or 35 in.).

- > Fill the cavities of the 180 mm units with clean stone.
- > It is required to use concrete adhesive between each row of Vario Wall when installed in a double-sided application.
- > At the very last row, turn the unit upside down to have the tongues downward. Then, use Techniseal concrete adhesive to glue the capping unit of your choice.

No accessory required for the Vario Wall.

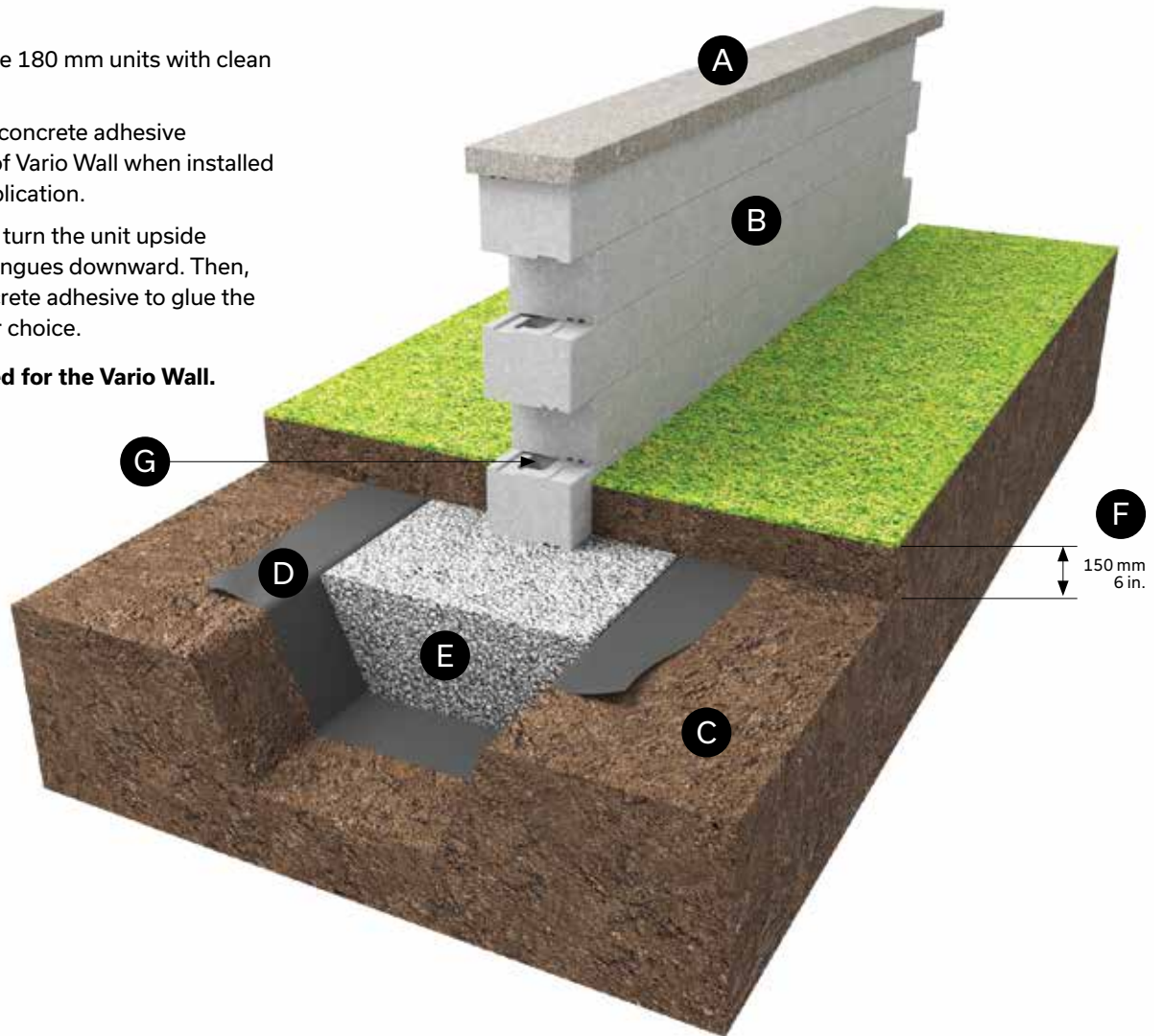

ISOMETRIC VIEW

- A** Capping
- B** Vario Wall 90 mm
- C** Undisturbed soil
- D** Geotextile membrane
- E** Compacted granular foundation: 0 to 20 mm - 0 to 3/4 in.
Depth: 300 mm - 12 in. minimum
- F** Minimum buried depth 150 mm - 6 in.

Maximum double-sided wall heights assume there is no soil to retain nor any surcharge

CROSS-SECTION - DOUBLE-SIDED WALL

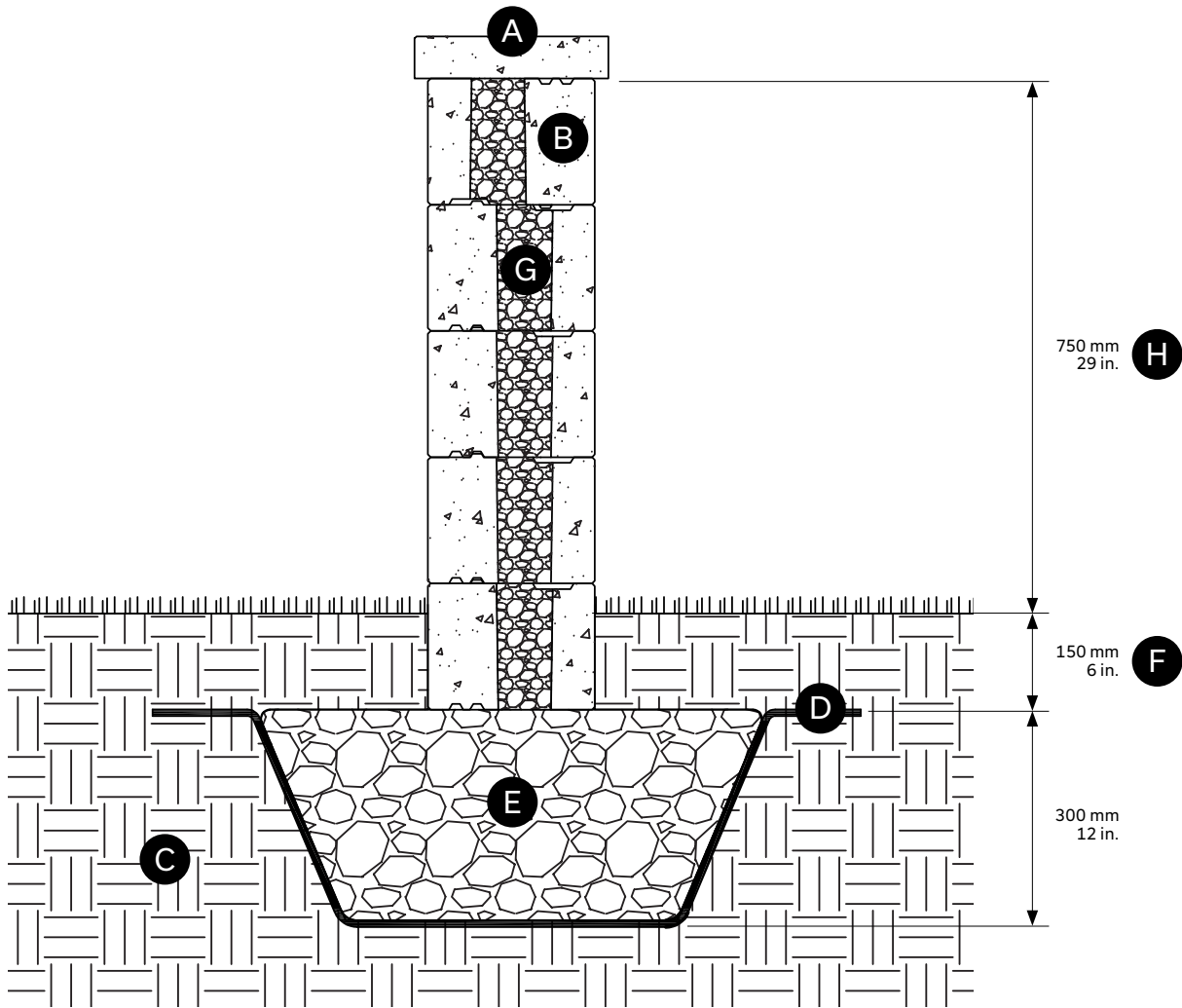

- Ⓐ Capping
- Ⓑ Vario Wall 90 mm
- Ⓒ Undisturbed soil
- Ⓓ Geotextile membrane
- Ⓔ Compacted granular foundation: 0 to 20 mm - 0 to 3/4 in.
Depth: 300 mm - 12 in. minimum
- Ⓕ Minimum buried depth 150 mm - 6 in.
- Ⓖ Clean stone (in the wall cavities)
- Ⓗ Maximum height without surcharges or slopes behind the wall, excluding the buried units and capping

CROSS-SECTION - CREATING VARIO WALL STEPS

To create steps, install the Melville Plus 60 step combined with the Vario wall units used as risers, as detailed below:

To complete the last row, turn the exposed unit upside down to have the tongues downward. Then, use Techniseal concrete adhesive to glue the step unit.

No accessory required for the Vario Wall. You don't have to use concrete adhesive between each row of the Vario Wall.

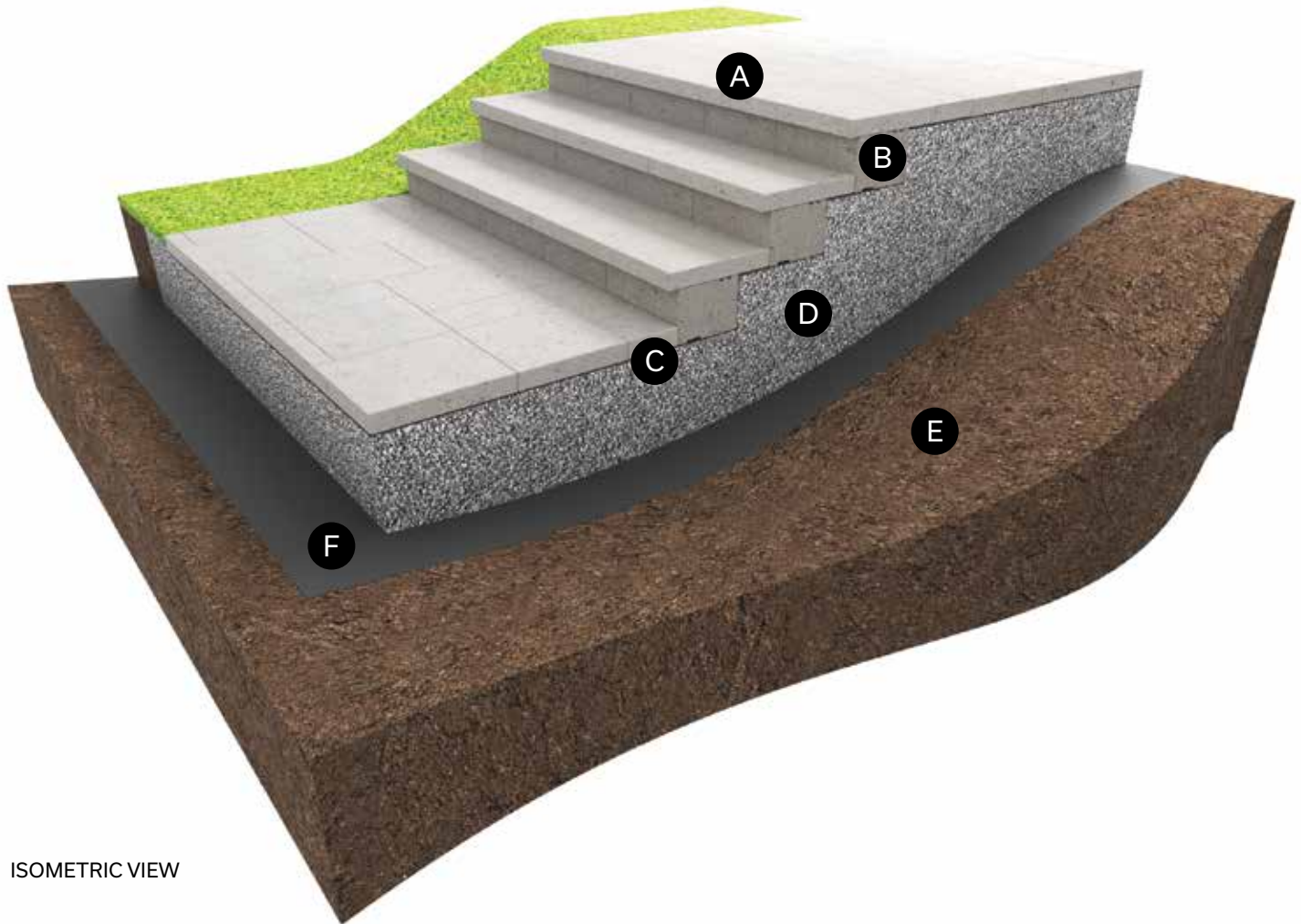

- A** Melville Plus 60 Step
- B** Vario Wall 180 mm
- C** Laying bed: 25 mm - 1 in.
- D** Compacted granular foundation:
0 to 20 mm - 0 to 3/4 in.
Depth: 300 mm - 12 in. minimum
- E** Undisturbed soil
- F** Geotextile membrane

CROSS-SECTION - WALL STEP INSTALLATION

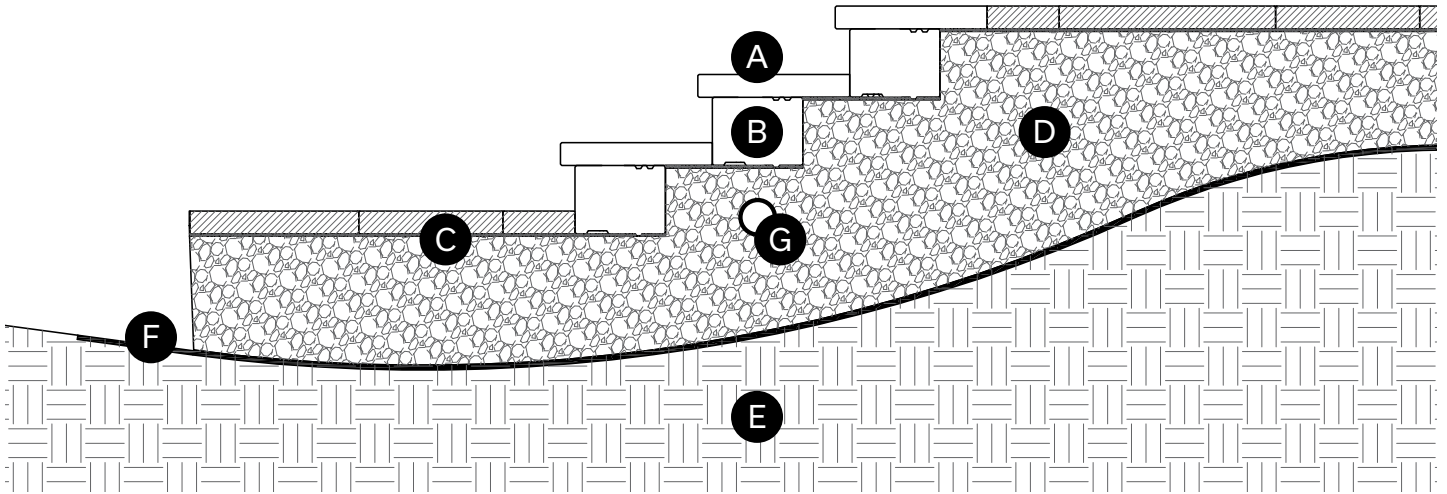

- Ⓐ Melville Plus 60 Step
- Ⓑ Vario Wall 180 mm
- Ⓒ Laying bed: 25 mm - 1 in.
- Ⓓ Compacted granular foundation:
0 to 20 mm - 0 to 3/4 in.
Depth: 300 mm - 12 in. minimum
- Ⓔ Undisturbed soil
- Ⓕ Geotextile membrane
- Ⓖ Perforated drain connected to services:
100 mm Ø - 4 in.

6 ROW SETBACK WALL – WITH SURCHARGE, NO SLOPE

Vario Wall 180 mm installed with a setback and geogrid – 6 rows (total height of 1080 mm or 42 in.). With surcharge behind the wall (5kPa), no slope.

- > Create the setback by installing the groove (female) on the inner tongue (male) of every row
- > Always install with tongue towards the outside of the wall
- > Fill the cavities of the 180 mm units with clean stone
- > Add a geogrid of 1250 mm (50 in.) long over the Vario wall unit. The geogrid is held by the tongue and groove system and the weight of the clean stone. Recommended geogrid: Miragrid 2XT
- > At the very last row, turn the unit upside down to have the tongue downward. Then, use Techniseal concrete adhesive to glue the Permacon capping of your choice.
- > You don't have to use concrete adhesive between each row of the Vario Wall.

Maximum wall heights assume there is a 5kPa surcharge behind the wall and no slope, and that the wall retains sand or gravel [$\phi = 34$ degrees, $\gamma = 19$ kN/m³].

CROSS-SECTION - 6 ROW SETBACK WALL - WITH SURCHARGE, NO SLOPE

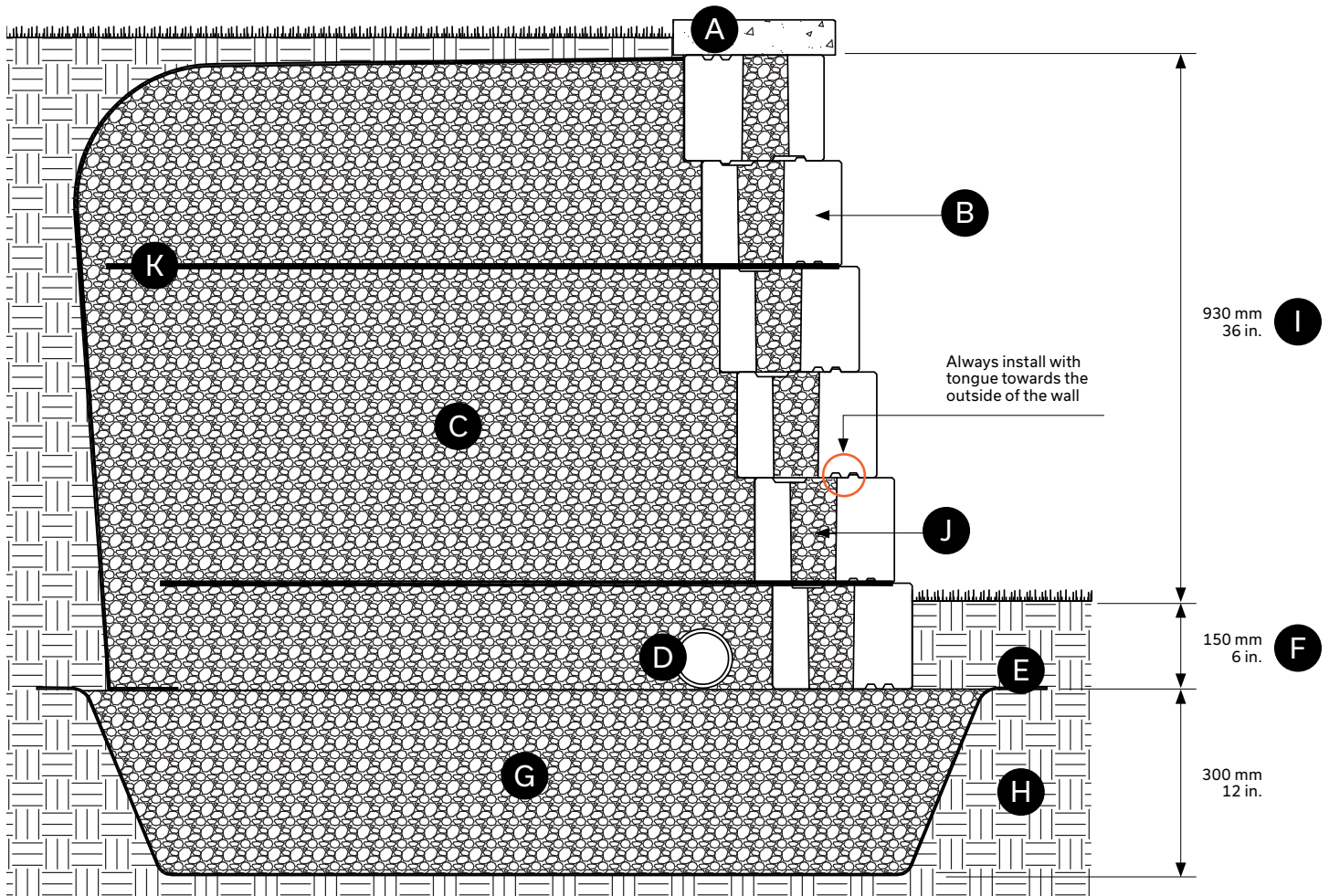

- Ⓐ Capping
- Ⓑ Vario Wall 180 mm (setback angle: 9.46 degrees, 150 mm)
- Ⓒ Clean stone 20 mm - 3/4 in. - Depth: 1400 mm - 55 in. min.
- Ⓓ Perforated drain connected to services: 100 mm Ø - 4 in.
- Ⓔ Geotextile membrane
- Ⓕ Minimum buried depth 150 mm - 6 in.
- Ⓖ Compacted granular foundation: 0 to 20 mm - 0 to 3/4 in. - Depth: 300 mm - 12 in. minimum
- Ⓗ Undisturbed soil
- Ⓘ Maximum height with surcharge and no slope behind the wall, excluding the buried units and capping
- Ⓙ Clean stone (in the unit cavities)
- Ⓚ Geogrid 1250 mm - 50 in.

9 ROW SETBACK WALL – WITH SURCHARGE, NO SLOPE

Vario Wall 180 mm installed with a setback and geogrid – 9 rows (total height of 1620 mm or 63 in.). With surcharge behind the wall (5kPa), no slope.

- > Create the setback by installing the outer groove (female) on the tongue (male) at every row
- > Always install with tongue towards the outside of the wall
- > Fill the cavities of the 180 mm units with clean stone
- > Add a geogrid of 1250 mm (50 in.) long over the Vario wall unit. The geogrid is held by the tongue and groove system and the weight of the clean stone. Recommended geogrid: Miragrid 2XT
- > At the very last row, turn the unit upside down to have the tongue downward. Then, use Techniseal concrete adhesive to glue the Permacon capping of your choice.

You don't have to use concrete adhesive between each row of the Vario Wall.

Maximum wall heights assume there is a 5kPa surcharge behind the wall and no slope, and that the wall retains sand or gravel [$\phi = 34$ degrees, $\gamma = 19$ kN/m³].

CROSS-SECTION - 9 ROW SETBACK WALL - WITH SURCHARGE, NO SLOPE

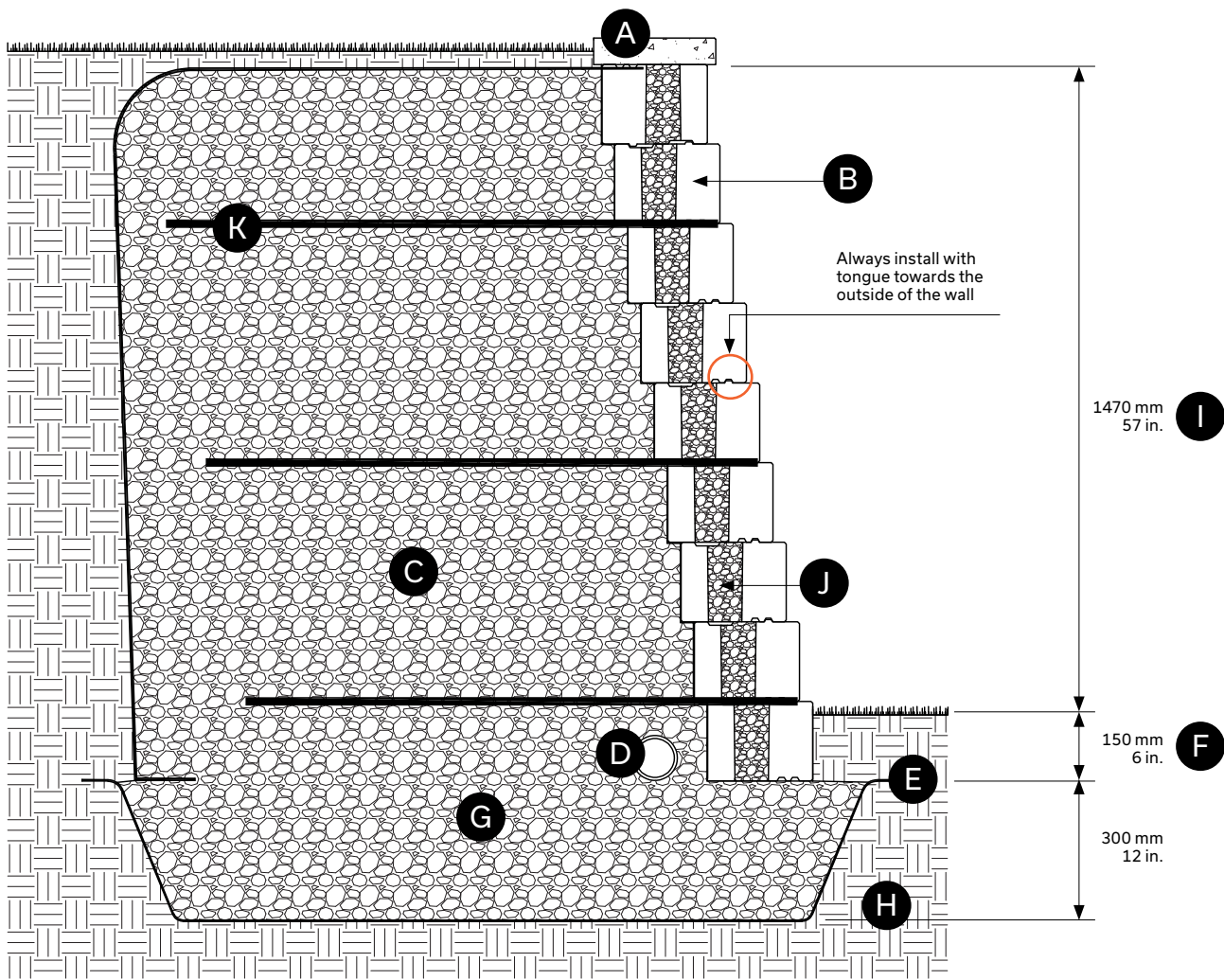

- Ⓐ Capping
- Ⓑ Vario Wall 180 mm (setback angle: 9.46 degrees, 240 mm)
- Ⓒ Clean stone 20 mm - 3/4 in. - Depth: 1490 mm - 59 in. min.
- Ⓓ Perforated drain connected to services: 100 mm Ø - 4 in.
- Ⓔ Geotextile membrane
- Ⓕ Minimum buried depth 150 mm - 6 in.
- Ⓖ Compacted granular foundation: 0 to 20 mm - 0 to 3/4 in. - Depth: 300 mm - 12 in. minimum
- Ⓗ Undisturbed soil
- Ⓘ Maximum height with surcharge and no slope behind the wall, excluding the buried units and capping
- Ⓙ Clean stone (in the wall cavities)
- Ⓚ Geogrid 1250 mm - 50 in.

12 ROW SETBACK WALL – WITH SURCHARGE, NO SLOPE

Vario Wall 180 mm installed with a setback and geogrid – 12 rows (total height of 2160 mm or 84 in.). With surcharge behind the wall (5kPa), no slope.

- > Create the setback by installing the outer groove (female) on the tongue (male) at every row
- > Always install with tongue towards the outside of the wall
- > Fill the cavities of the 180 mm units with clean stone
- > Add a geogrid of 1550 mm (61 in.) long over the Vario wall unit. The geogrid is held by the tongue and groove system and the weight of the clean stone. Recommended geogrid: Miragrid 2XT
- > At the very last row, turn the unit upside down to have the tongue downward. Then, use Techniseal concrete adhesive to glue the Permacon capping of your choice.

You don't have to use concrete adhesive between each row of the Vario Wall.

Maximum wall heights assume there is a 5kPa surcharge behind the wall and no slope, and that the wall retains sand or gravel [$\phi = 34$ degrees, $\gamma = 19$ kN/m³].

CROSS-SECTION - 12 ROW SETBACK WALL - WITH SURCHARGE, NO SLOPE

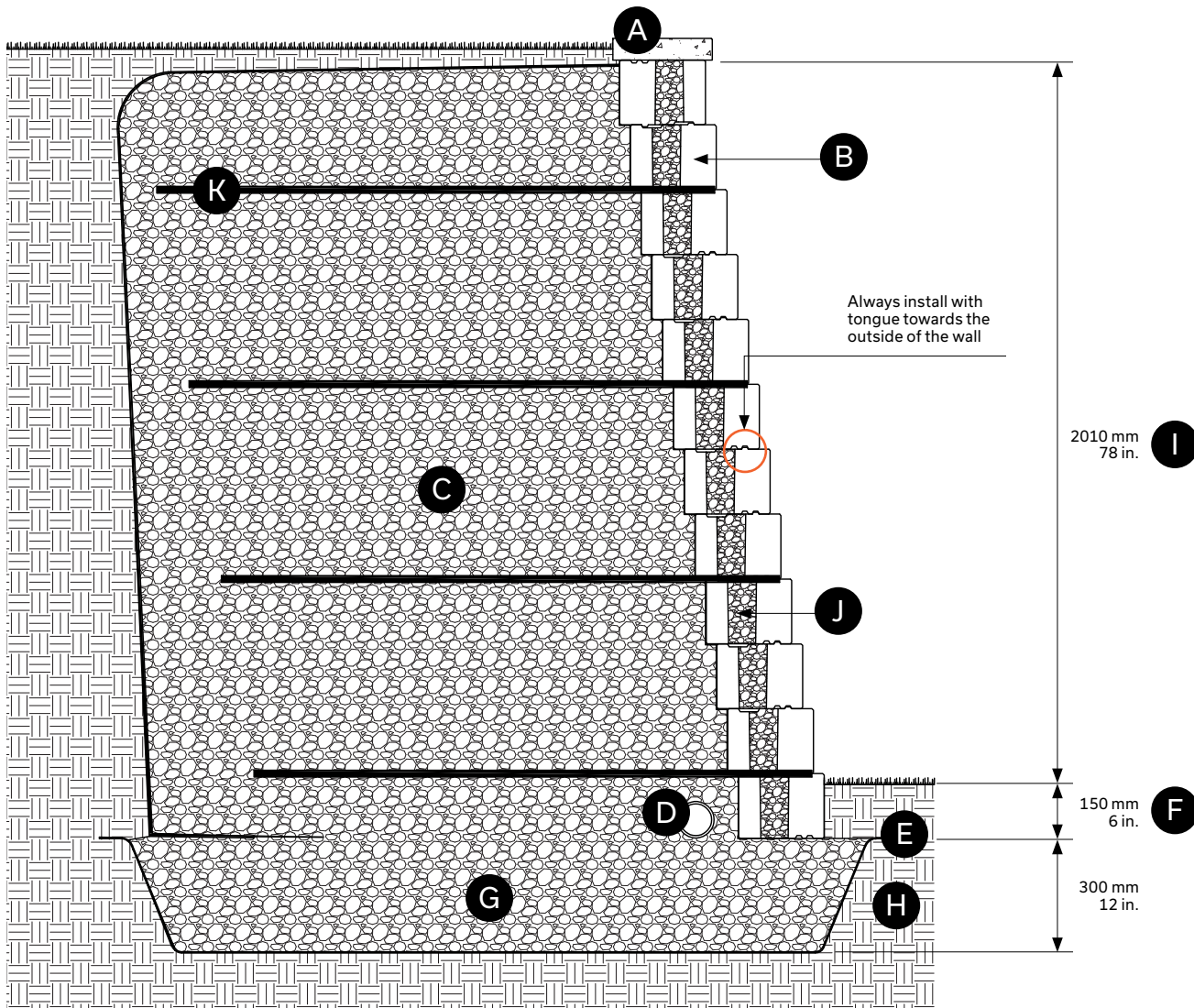

- A Capping
- B Vario Wall 180 mm (setback angle: 9.46 degrees, 330 mm)
- C Clean stone 20 mm - 3/4 in. - Depth: 1880 mm - 74 in. min.
- D Perforated drain connected to services: 100 mm Ø - 4 in.
- E Geotextile membrane
- F Minimum buried depth 150 mm - 6 in.
- G Compacted granular foundation: 0 to 20 mm - 0 to 3/4 in. - Depth: 300 mm - 12 in. minimum
- H Undisturbed soil
- I Maximum height with surcharge and no slope behind the wall, excluding the buried units and capping
- J Clean stone (in the wall cavities)
- K Geogrid 1550 mm - 61 in.

15 ROW SETBACK WALL – WITH SURCHARGE, NO SLOPE

Vario Wall 180 mm installed with a setback and geogrid – 15 rows (total height of 2700 mm or 105 in.). With surcharge behind the wall (5kPa), no slope.

- > Create the setback by installing the outer groove (female) on the tongue (male) at every row
- > Always install with tongue towards the outside of the wall
- > Fill the cavities of the 180 mm units with clean stone
- > Add a geogrid of 1885 mm (74 in.) long over the Vario wall unit. The geogrid is held by the tongue and groove system and the weight of the clean stone. Recommended geogrid: Miragrid 2XT
- > At the very last row, turn the unit upside down to have the tongue downward. Then, use Techniseal concrete adhesive to glue the Permacon capping of your choice.

You don't have to use concrete adhesive between each row of the Vario Wall.

Maximum wall heights assume there is a 5kPa surcharge behind the wall and no slope, and that the wall retains sand or gravel [$\phi = 34$ degrees, $\gamma = 19$ kN/m³].

CROSS-SECTION - 15 ROW SETBACK WALL - WITH SURCHARGE, NO SLOPE

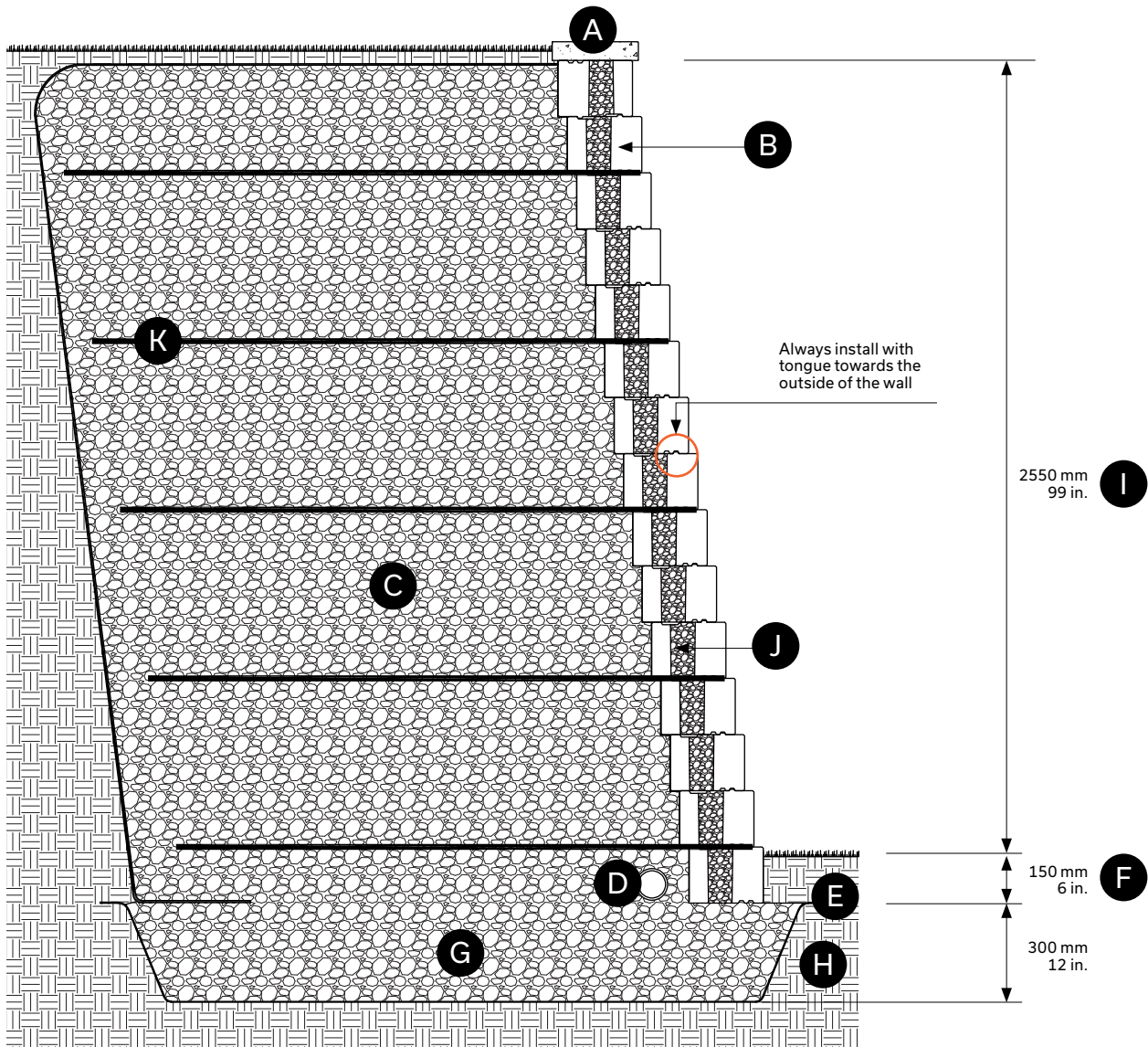

- A Capping
- B Vario Wall 180 mm (setback angle: 9.46 degrees, 420 mm)
- C Clean stone 20 mm - 3/4 in. - Depth: 2270 mm - 89 in. min.
- D Perforated drain connected to services: 100 mm Ø - 4 in.
- E Geotextile membrane
- F Minimum buried depth 150 mm - 6 in.
- G Compacted granular foundation: 0 to 20 mm - 0 to 3/4 in. - Depth: 300 mm - 12 in. minimum
- H Undisturbed soil
- I Maximum height with surcharge and no slope behind the wall, excluding the buried units and capping
- J Clean stone (in the wall cavities)
- K Geogrid 1885 mm - 74 in.

6 ROW VERTICAL WALL – WITH SURCHARGE, NO SLOPE

Vario Wall 180 mm installed in a vertical application with geogrid – 6 rows (total height of 1080 mm or 42 in). With surcharge (5 kPa), no slope.

- > With surcharge (5 kPa), no slope.
- > Always position the tongue on the outer side of the wall
- > Fill the cavities of the 180 mm units with clean stone
- > Add a 1250 mm long geogrid (50 in.) over the Vario Wall unit. The geogrid is held by the tongue and groove system and the weight of the clean stone. Recommended geogrid: Miragrid 2XT
- > At the very last row, turn the unit upside down to have the tongue downward. Then, use Techniseal concrete adhesive to glue the Permacon capping of your choice.

You don't have to use concrete adhesive between each row of the Vario Wall.

Maximum wall heights assume there is a 5kPa surcharge behind the wall and no slope, and that the wall retains sand or gravel [$\phi = 34$ degrees, $\gamma = 19$ kN/m³].

CROSS-SECTION - 6 ROW VERTICALWALL - WITH SURCHARGE, NO SLOPE

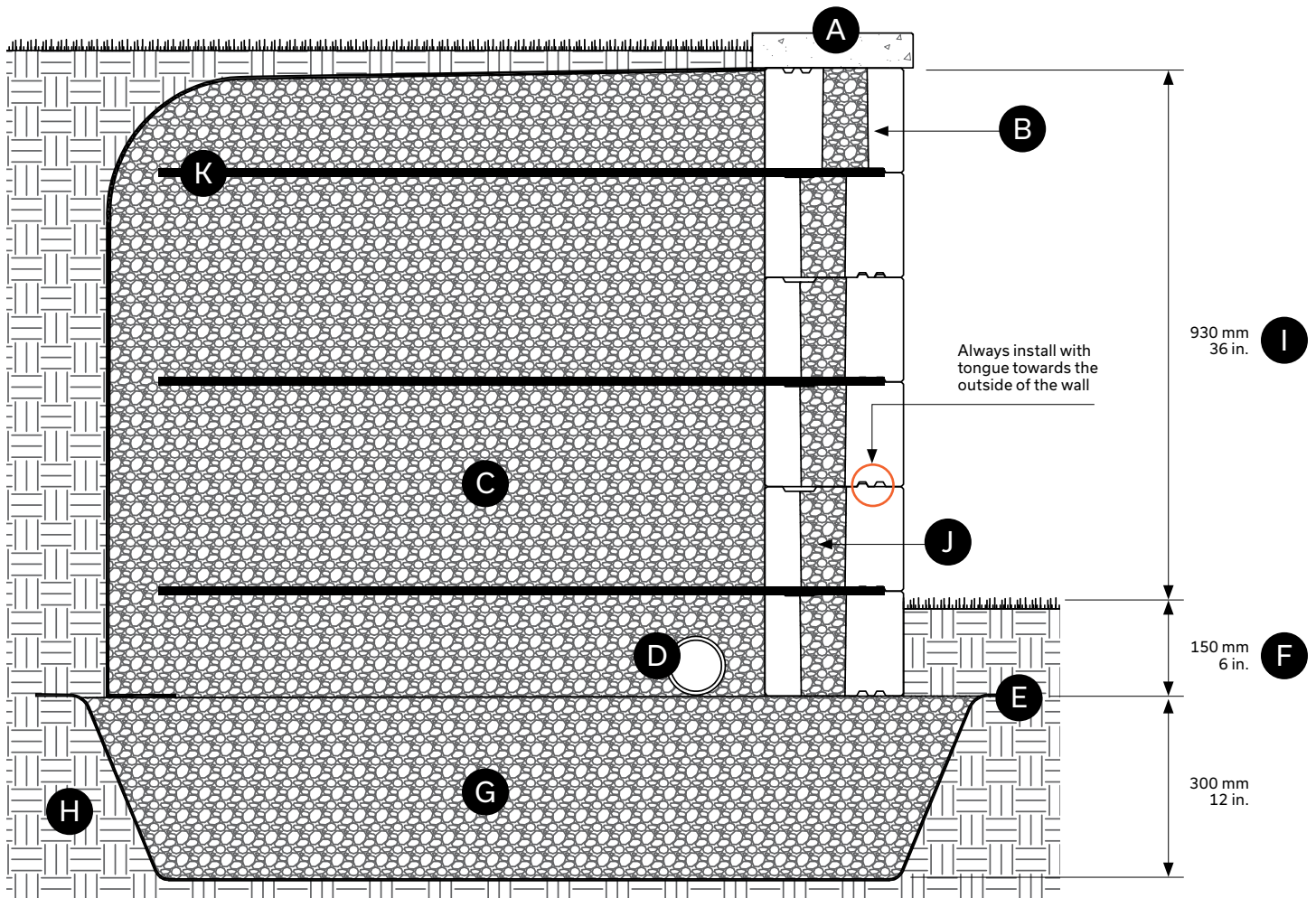

- (A) Capping
- (B) Vario Wall 180 mm
- (C) Clean stone 20 mm - 3/4 in. - Depth: 1400 mm - 55 in. min.
- (D) Perforated drain connected to services: 100 mm Ø - 4 in.
- (E) Geotextile membrane
- (F) Minimum buried depth 150 mm - 6 in.
- (G) Compacted granular foundation: 0 to 20 mm - 0 to 3/4 in. - Depth: 300 mm - 12 in. minimum
- (H) Undisturbed soil
- (I) Maximum height with surcharge and no slope behind the wall, excluding the buried units and capping
- (J) Clean stone (in the unit cavities)
- (K) Geogrid 1250 mm - 50 in.

9 ROW VERTICAL WALL – WITH SURCHARGE, NO SLOPE

Vario Wall 180 mm installed in a vertical application with geogrid – 9 rows (total height of 1620 mm or 63 in). With surcharge (5 kPa), no slope.

- > Always position the tongue on the outer side of the wall
- > Fill the cavities of the 180 mm units with clean stone
- > Add a 1250 mm long geogrid (50 in.) over the Vario Wall unit. The geogrid is held by the tongue and groove system and the weight of the clean stone. Recommended geogrid: Miragrid 2XT
- > At the very last row, turn the unit upside down to have the tongue downward. Then, use Techniseal concrete adhesive to glue the Permacon capping of your choice.

You don't have to use concrete adhesive between each row of the Vario Wall.

Maximum wall heights assume there is a 5kPa surcharge behind the wall and no slope, and that the wall retains sand or gravel [$\phi = 34$ degrees, $\gamma = 19$ kN/m³].

CROSS-SECTION - 9 ROW VERTICAL WALL - WITH SURCHARGE, NO SLOPE

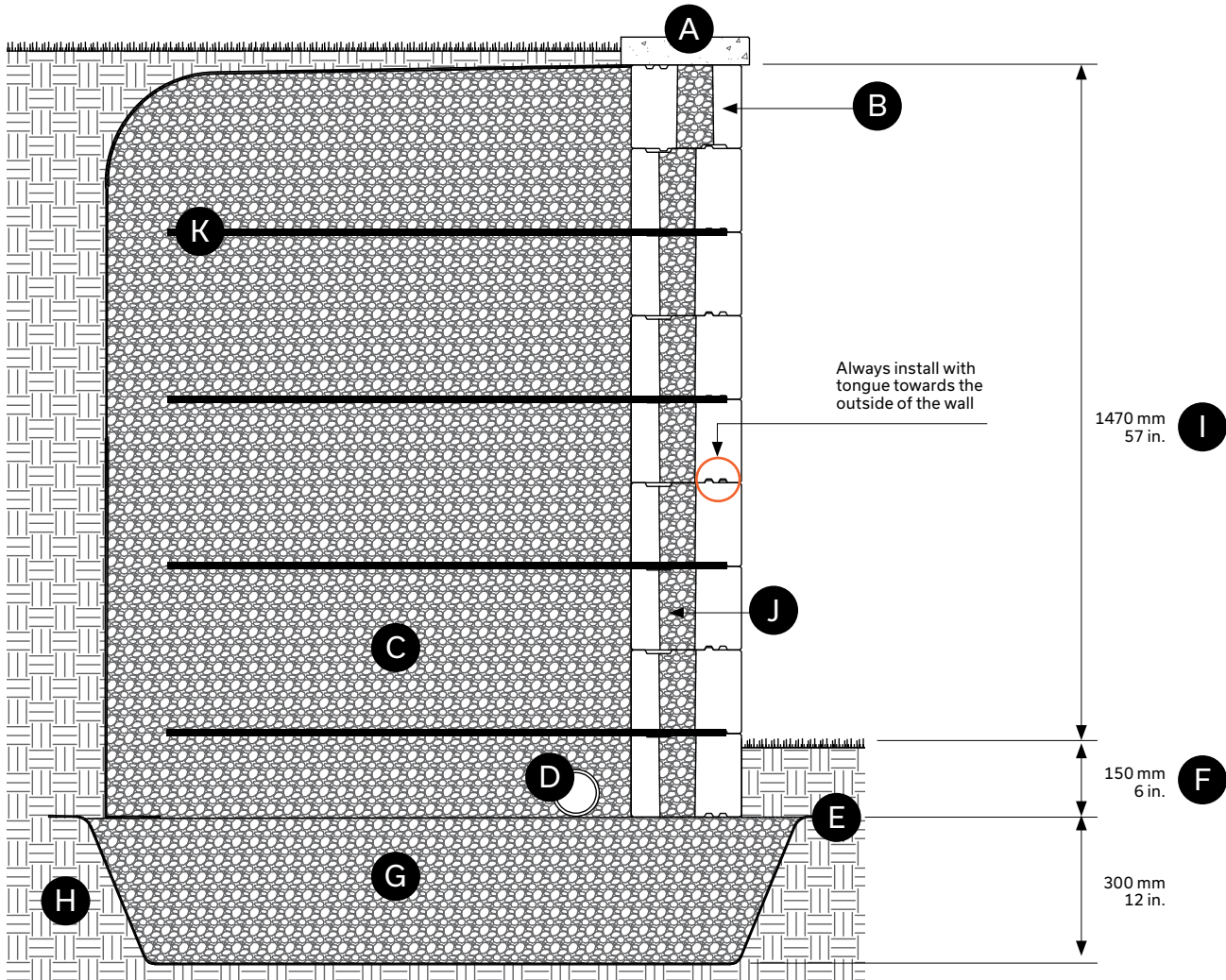

- Ⓐ Capping
- Ⓑ Vario Wall 180 mm
- Ⓒ Clean stone 20 mm - 3/4 in. - Depth: 1490 mm - 59 in. min.
- Ⓓ Perforated drain connected to services: 100 mm Ø - 4 in.
- Ⓔ Geotextile membrane
- Ⓕ Minimum buried depth 150 mm - 6 in.
- Ⓖ Compacted granular foundation: 0 to 20 mm - 0 to 3/4 in. - Depth: 300 mm - 12 in. minimum
- Ⓗ Undisturbed soil
- Ⓘ Maximum height with surcharge and no slope behind the wall, excluding the buried units and capping
- Ⓝ Clean stone (in the wall cavities)
- Ⓚ Geogrid 1250 mm - 50 in.

12 ROW VERTICAL WALL – WITH SURCHARGE, NO SLOPE

Vario Wall 180 mm installed in a vertical application with geogrid – 12 rows (total height of 2160 mm or 84 in). With surcharge (5 kPa), no slope.

- > Always position the tongue on the outer side of the wall
- > Fill the cavities of the 180 mm units with clean stone
- > Add a 1550 mm long geogrid (61 in.) over the Vario Wall unit. The geogrid is held by the tongue and groove system and the weight of the clean stone. Recommended geogrid: Miragrid 2XT
- > At the very last row, turn the unit upside down to have the tongue downward. Then, use Techniseal concrete adhesive to glue the Permacon capping of your choice.

You don't have to use concrete adhesive between each row of the Vario Wall.

Maximum wall heights assume there is a 5kPa surcharge behind the wall and no slope, and that the wall retains sand or gravel [$\phi = 34$ degrees, $\gamma = 19$ kN/m³].

CROSS-SECTION - 12 ROW VERTICAL WALL - WITH SURCHARGE, NO SLOPE

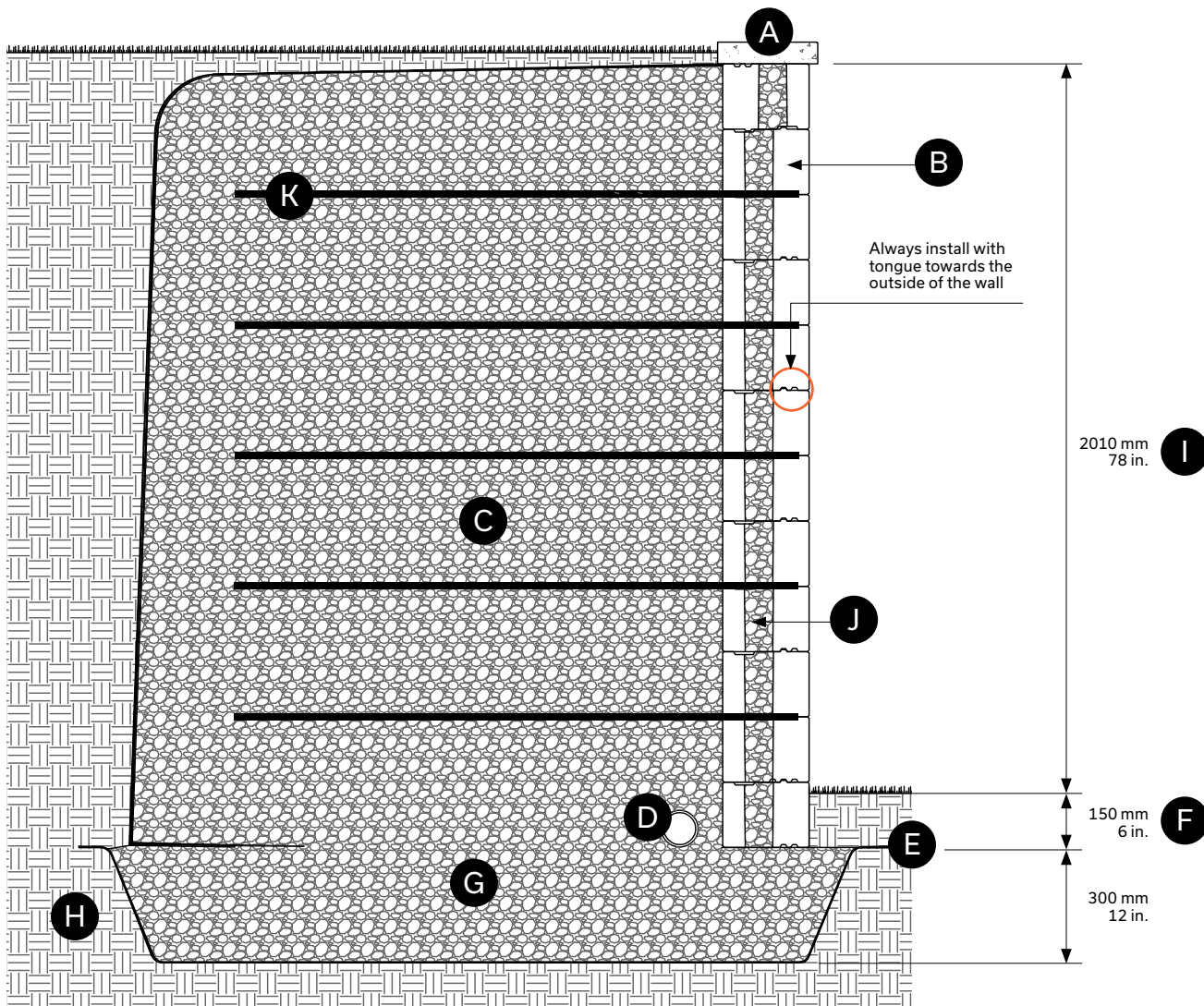

- Ⓐ Capping
- Ⓑ Vario Wall 180 mm
- Ⓒ Clean stone 20 mm - 3/4 in. - Depth: 1880 mm - 74 in. min.
- Ⓓ Perforated drain connected to services: 100 mm Ø - 4 in.
- Ⓔ Geotextile membrane
- Ⓕ Minimum buried depth 150 mm - 6 in.
- Ⓖ Compacted granular foundation: 0 to 20 mm - 0 to 3/4 in. - Depth: 300 mm - 12 in. minimum
- Ⓗ Undisturbed soil
- Ⓘ Maximum height with surcharge and no slope behind the wall, excluding the buried units and capping
- Ⓙ Clean stone (in the wall cavities)
- Ⓚ Geogrid 1550 mm - 61 in.

15 ROW VERTICAL WALL – WITH SURCHARGE, NO SLOPE

Vario Wall 180 mm installed in a vertical application with geogrid
– 15 rows (total height of 2700 mm or 105 in). With surcharge
(5 kPa), no slope.

- > Always position the tongue on the outer side of the wall
- > Fill the cavities of the 180 mm units with clean stone
- > Add a 1885 mm long geogrid (74 in.) over the Vario Wall unit. The geogrid is held by the tongue and groove system and the weight of the clean stone. Recommended geogrid: Miragrid 2XT
- > At the very last row, turn the unit upside down to have the tongue downward. Then, use Techniseal concrete adhesive to glue the Permacon capping of your choice.

You don't have to use concrete adhesive between each row of the Vario Wall.

Maximum wall heights assume there is a 5kPa surcharge behind the wall and no slope, and that the wall retains sand or gravel [$\phi = 34$ degrees, $\gamma = 19$ kN/m³].

CROSS-SECTION - 15 ROW VERTICAL WALL - WITH SURCHARGE, NO SLOPE

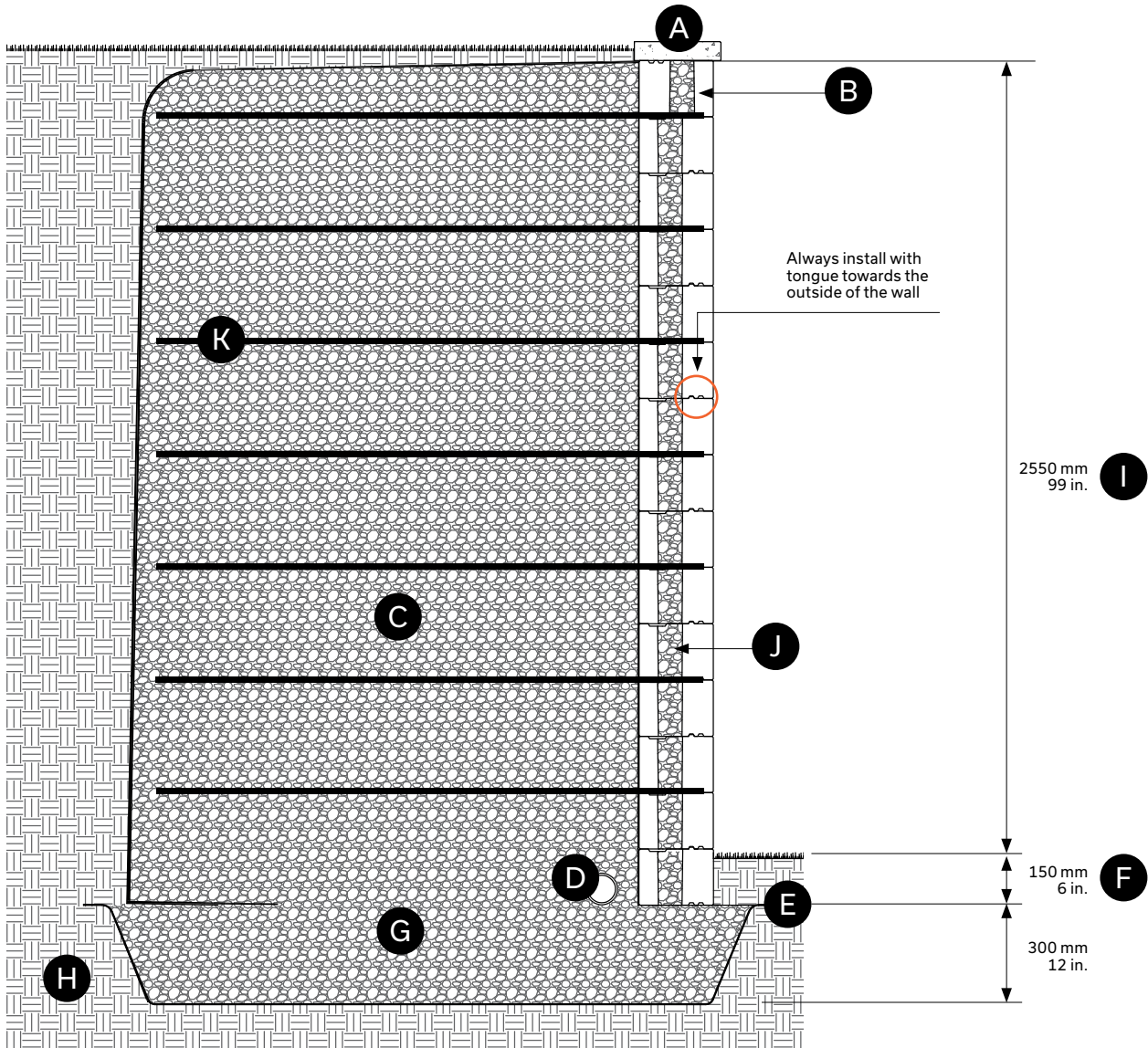

- A** Capping
- B** Vario Wall 180 mm (setback angle: 9.46 degrees, 420 mm)
- C** Clean stone 20 mm - 3/4 in. - Depth: 2270 mm - 89 in. min.
- D** Perforated drain connected to services: 100 mm Ø - 4 in.
- E** Geotextile membrane
- F** Minimum buried depth 150 mm - 6 in.
- G** Compacted granular foundation: 0 to 20 mm - 0 to 3/4 in. - Depth: 300 mm - 12 in. minimum
- H** Undisturbed soil
- I** Maximum height with surcharge and no slope behind the wall, excluding the buried units and capping
- J** Clean stone (in the wall cavities)
- K** Geogrid 1885 mm - 74 in.

Wallstone and Wedgestone Walls

DESCRIPTION

Wallstone and Wedgestone wall can be used separately or in combination for greater flexibility.

Suitable for gravity or grid, vertical or setback, straight or curved walls. All Wallstone and Wedgestone wall component units come pre-split. End grooves on Wallstone standard units maintain interlock between courses, even when placed vertically. Two thirds of standard units are also double rock-faced.

Wedgestone wall units are 100% double rock-faced and reversible for inside and outside curves. Units create a 600 mm - 2 in. outside radius without cutting.

TIP

4 Wedgestone wall units are required for a rounded 90° corner, 16 pcs for a full circle.

Patterned Wallstone walls can be stacked vertically up to 6 courses high (7 courses if using a Wallstone double unit in the base) or up to 8 courses if 50% of units have at least a one groove setback and a Wallstone double unit is used in the base course.

WALLSTONE UNITS

STANDARD UNIT

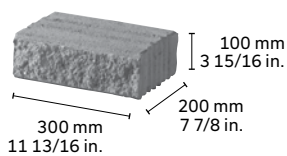

12 IN. CAPPING UNIT

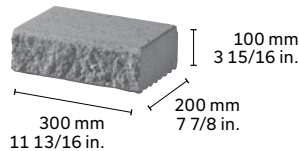

CORNER/COLUMN UNIT

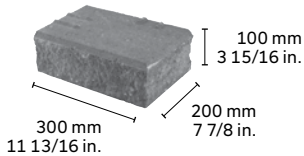

WEDGESTONE UNITS

STANDARD UNIT

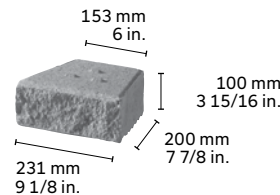

CAPPING UNIT

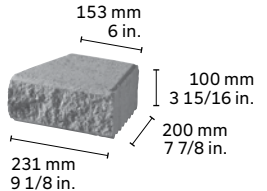

PATTERNS

PATTERN 1

Place Wallstone standard units vertically and horizontally to create interesting patterns within the wall.

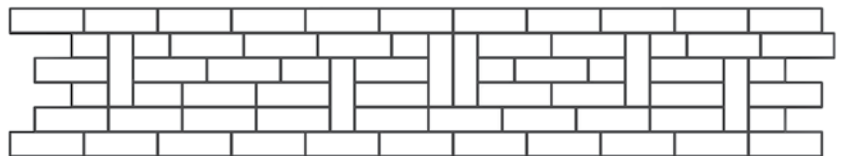

PATTERN 2

Add an additional dimension to your wall by including Wedgestone wall units in your pattern (shaded).

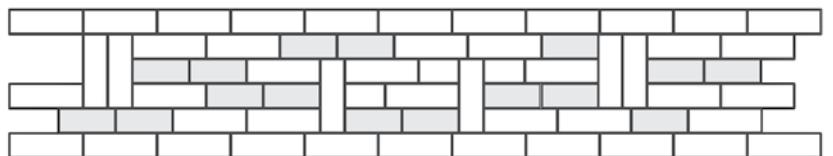

Consider recessing blocks to add further distinction. Except for the capping course, it is not recommended to set units forward beyond the front of the base course.

WALLSTONE AND WEDGESTONE WALLS

CROSS-SECTION -SETBACK GRAVITY WALL

2 FOOT WALL HEIGHT

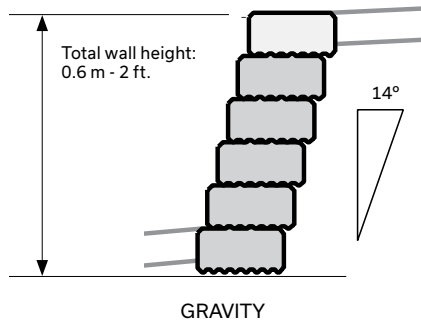

6 FOOT WALL HEIGHT

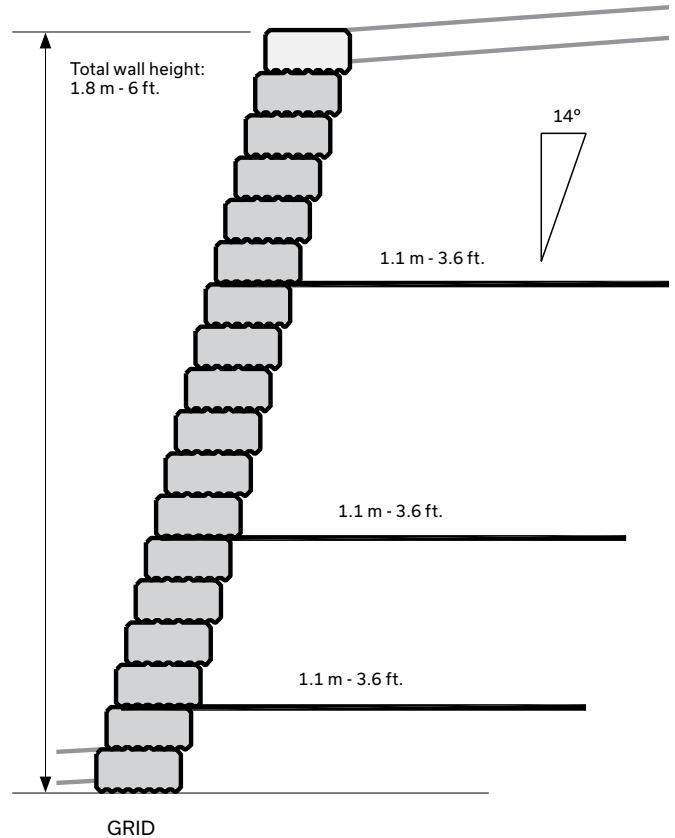

4 FOOT WALL HEIGHT

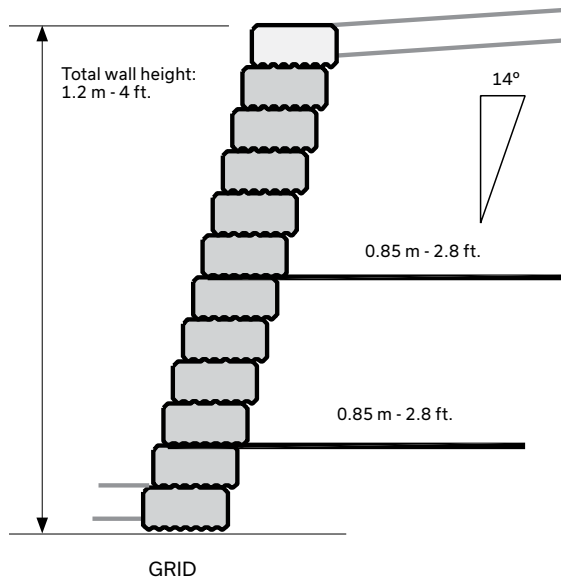

NOTES:

- 01 - Sample designs based on 2.4 kPa (50 psf) pedestrian surcharge. Use as preliminary design only when actual soil and surcharge conditions are conservatively represented by the standard engineering. In all cases, designs should be reviewed by a geotechnical engineer to ensure applicability to site.
- 02 - Designs consider free draining sand and gravel backfill material compacted to 95% SPMDD to a minimum depth of 375 mm - 15 in. behind the wall or to full extent of geogrid reinforcement, whichever is greater. Backfill materials to have less than 8% passing through the # 200 sieve.
- 03 - Designs consider 19 mm - 0 to 3/4 in. well graded, crushed angular granular materials for a minimum depth of 200 mm - 8 in. under the wall compacted to 98% SPMDD. Material to have less than 8% passing through the # 200 sieve.
- 04 - Designs consider minimum bearing capacity in subgrade soil below wall of 150 kPa (3000 psf).
- 05 - Different batter configurations, surcharge conditions or wall heights require different design configurations.
- 06 - No provision has been made for overall global stability of the designs.
- 07 - Minimum 100 mm - 4 in. of product must be buried in all situations. Design may require more depending on soil conditions or toe slope.
- 08 - Grid lengths are measured from front face of wall.
- 09 - Geogrid used in designs is Miragrid 2XT or 3XT.
- 10 - Designs for wall heights, batters and surcharges not represented on these pages can be attained from Permacon.
- 11 - Refer to standard engineering drawings for further details.
- 12 - Total wall height for Wallstone wall does not include capping unit.
- 13 - Sample designs are not designed for handrail, guard or fence loading. In these cases, design modifications will be required.
- 14 - Poor soil conditions and excessive moisture will require drainage and design modifications.

WALLSTONE AND WEDGESTONE WALLS

CROSS-SECTION -SETBACK VERTICAL WALL

2 FOOT WALL HEIGHT

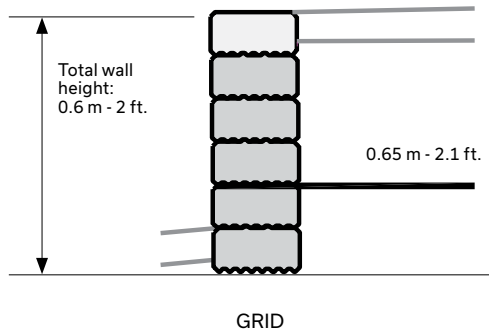

6 FOOT WALL HEIGHT

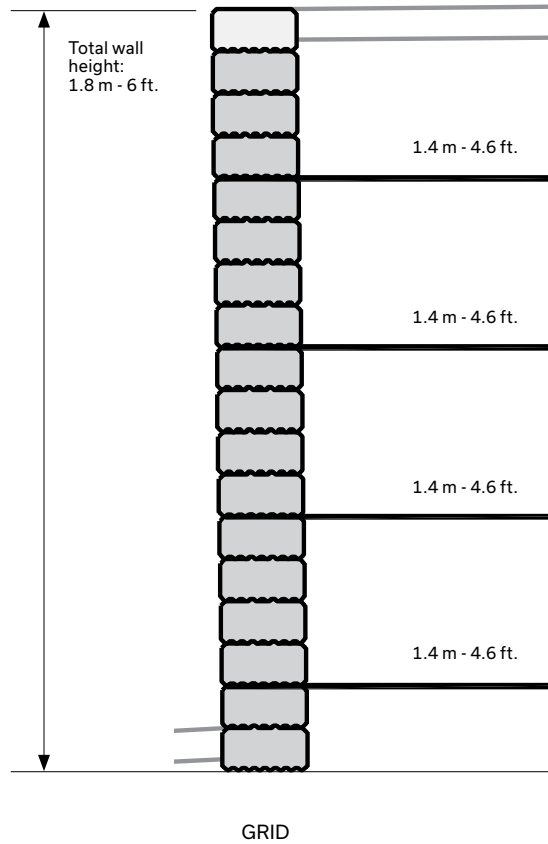

4 FOOT WALL HEIGHT

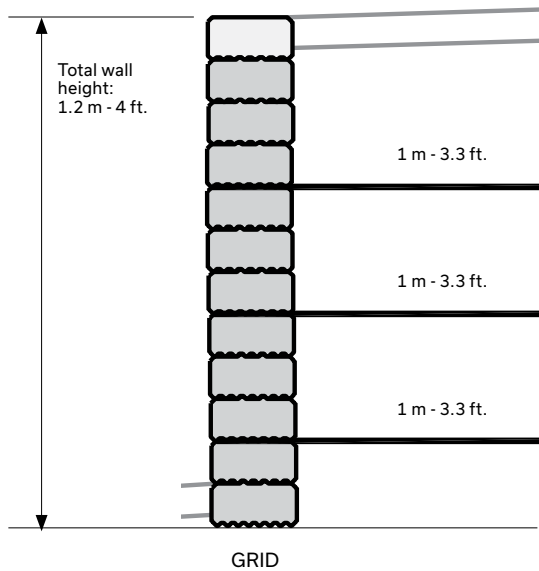

NOTES:

- 01 - Sample designs based on 2.4 kPa (50 psf) pedestrian surcharge. Use as preliminary design only when actual soil and surcharge conditions are conservatively represented by the standard engineering. In all cases, designs should be reviewed by a geotechnical engineer to ensure applicability to site.
- 02 - Designs consider free draining sand and gravel backfill material compacted to 95% SPMDD to a minimum depth of 375 mm - 15 in. behind the wall or to full extent of geogrid reinforcement, whichever is greater. Backfill materials to have less than 8% passing through the # 200 sieve.
- 03 - Designs consider 19 mm - 0 to 3/4 in. well graded, crushed angular granular materials for a minimum depth of 200 mm - 8 in. under the wall compacted to 98% SPMDD. Material to have less than 8% passing through the # 200 sieve.
- 04 - Designs consider minimum bearing capacity in subgrade soil below wall of 150 kPa (3000 psf).
- 05 - Different batter configurations, surcharge conditions or wall heights require different design configurations.
- 06 - No provision has been made for overall global stability of the designs.
- 07 - Minimum 100 mm - 4 in. of product must be buried in all situations. Design may require more depending on soil conditions or toe slope.
- 08 - Grid lengths are measured from front face of wall.
- 09 - Geogrid used in designs is Miragrid 2XT or 3XT.
- 10 - Designs for wall heights, batters and surcharges not represented on these pages can be attained from Permacon.
- 11 - Refer to standard engineering drawings for further details.
- 12 - Total wall height for Wallstone wall does not include capping unit.
- 13 - Sample designs are not designed for handrail, guard or fence loading. In these cases, design modifications will be required.
- 14 - Poor soil conditions and excessive moisture will require drainage and design modifications.

WALLSTONE AND WEDGESTONE WALLS

CORNER - SINGLE DEPTH

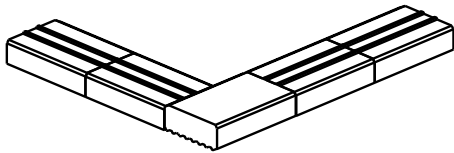

ROW A

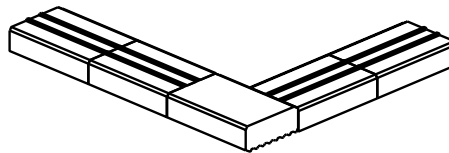

ROW B

CORNER - MULTI DEPTH

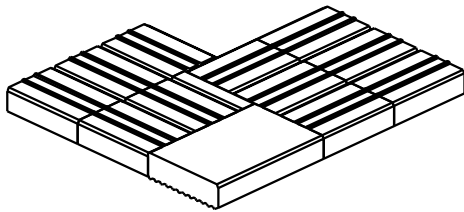

ROW A

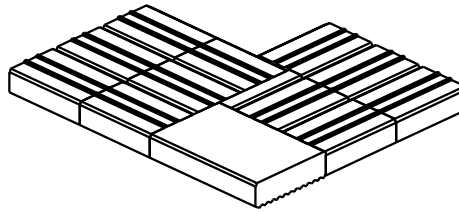

ROW B

STEPS

A double unit in the base of the bottom of the riser adds stability. Use 12 in. capping units as the stair tread.

TO CALCULATE PRODUCT REQUIREMENTS:

Double units = step width x 1

Standard units = step width x 2 x # of risers + step width x 1

Capping units = step width ÷ by capping width x # of risers

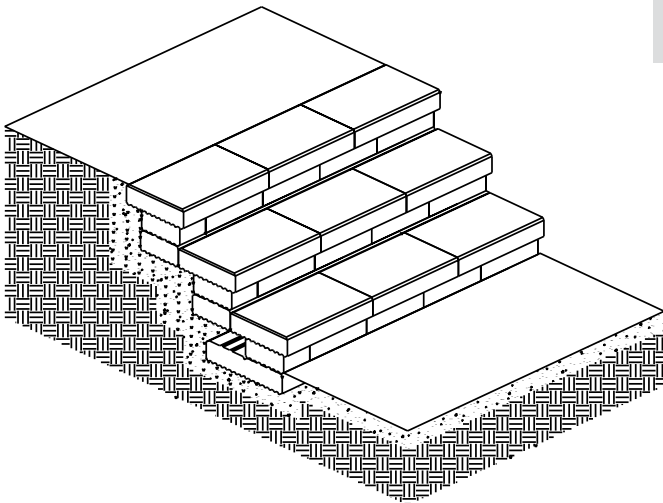

Wall Installation Guidelines

TYPICAL CROSS-SECTION - GRANDE, WALLSTONE AND RB WALL

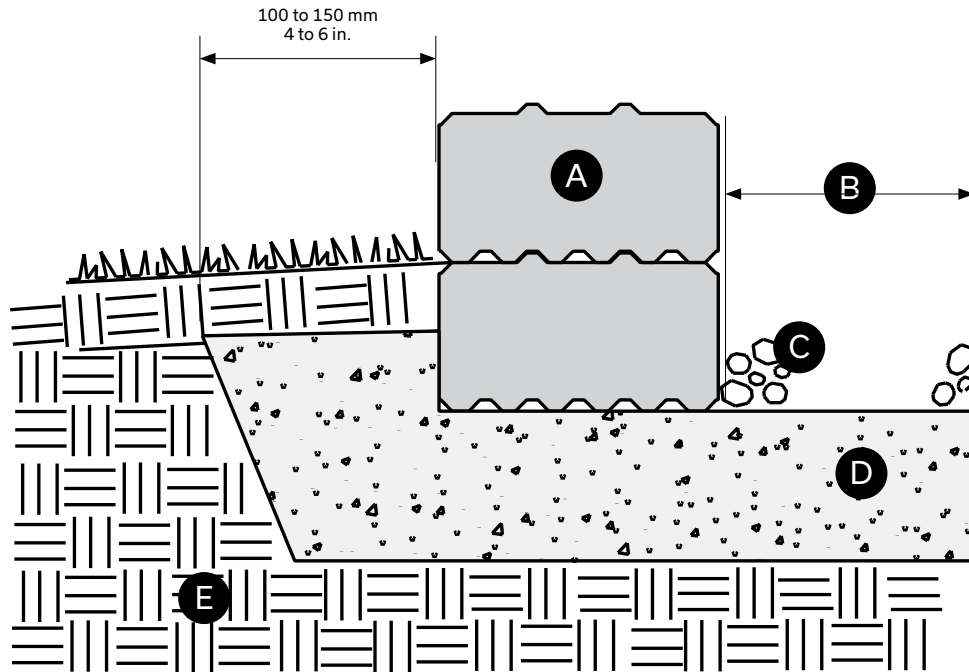

- **A** Retaining wall system manufactured by Permacon
- **B** Equal to depth of backfill: depth varies
- **C** Compacted granular backfill: depth varies
- **D** Compacted aggregate base: thickness varies (minimum 200 mm - 8 in.)
- **E** Compacted soil subgrade

WALL INSTALLATION GUIDELINES

GENERAL INFORMATION - GRANDE, WALLSTONE AND RB WALL

These installation guidelines apply to garden and decorative walls built with any Permacon retaining wall system. For large structural or retaining walls, walls that exceed the maximum recommended height or walls in areas of poor drainage of soil conditions, please contact your Permacon sales representative for more specific installation requirements.

DESIGN CONSIDERATIONS

When planning a garden or retaining wall, you should ask yourself several questions to ensure your finished installation will look good and last a lifetime.

- > How high will the wall be? Height of the wall should always include a minimum of one buried base course in addition to the height above ground. Different wall systems have different height capabilities. Be sure not to exceed the maximum recommended height for the wall product you choose.
- > Will the wall be straight, curved or both? Permacon Grande and Wallstone walls can create circles, soft flowing curves, straight linear designs or any of these in combination. Measure the curved and straight sections of the wall separately to make estimating easier.
- > What is the purpose of the wall? Some wall products are suitable for large retaining wall projects while others are ideal for small garden walls or planters.
- > Will the height of the wall vary? If the property has a slope, the wall height may vary accordingly. To make estimating easier, break the wall up into sections of equal height, always maintaining one buried base course.
- > Will the wall be terraced? If so, the front of the upper wall must be at least 1.5 times the height of the lower wall behind the back of the base course of the lower wall.
- > What setback do you need? Some Permacon wall products are capable of achieving vertical walls and other products have an automatic setback. Vertical walls typically can't go as high as setback walls without geogrid reinforcement. In addition, setback walls may require less product. When planning and measuring, keep in mind that a single setback moves the top of the wall back 25 mm (1") per course from the front of the base course.

Walls that exceed the maximum recommended height, walls in areas of poor drainage and walls with extra loading at the top may require special engineering. Please contact Permacon for more information if your wall falls into one of these categories.

EXCAVATION & BASE PREPARATION

Set an excavation line using a chalk or string line. To create an accurate radius, drive a stake into the ground at the desired center of your project. Attach a string to the stake equal in length to the desired inside radius. Rotate the string to indicate the location of the back of the first course. Once laid out, excavate a trench equal to the depth of gravel material plus the height of one unit, or to firm soil. The trench should be approximately 100 to 150 mm - 4 to 6 in. wider than the wall block you have chosen.

After excavation, spread the base material uniformly throughout the trench with a hard toothed rake in layers of no more than 100 mm - 4in. Use the vibrating or hand tamper to compact the entire area evenly. Continue spreading and compacting base material until the desired depth is achieved and the surface has no low or high areas.

Place screed rails at the desired grade of the underside of the first course of wall. Level the screed rails with a 4 foot level or transit level. Place granular base material between the rails and screed level with a straight edge, such as a 2 x 4 timber. Compact this area with a hand tamper. After compacting, place more granular base material between the rails and screed level. This is the level surface for laying the wall base pieces.

BASE COURSE & WALL CONSTRUCTION

Start placing the base course on top of the compacted base, beginning at the lowest point of the wall. Check alignment and leveling as you proceed. Continue with additional courses, adding and compacting backfill material behind the wall after every second course. To ensure adequate interlock between courses, we recommend a minimum joint overlap of 1/4 bond.

To ensure proper color distribution, take pieces from several bundles at a time, removing them in stacks rather than by layer.

TIP: Check the levelness of the wall every 2-3 courses by putting a string line along the length of the wall.

Keystone Wall

DESCRIPTION



Permacon's Keystone retaining wall, made of textured concrete, is approved by the *Ministère des Transports et de la Mobilité durable* in the Province of Quebec. Designed to meet your needs for large retaining walls, our modular system makes it possible to build strong walls up to 32 ft. (10 m) high. For designing walls with a geogrid reinforcement, please contact your Permacon sales representative.

Design and installation may vary according to project and site. Please consult your Permacon representative.

CORNER UNIT

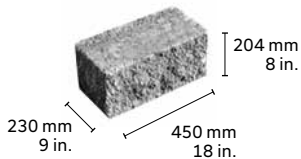

COMPACT UNIT

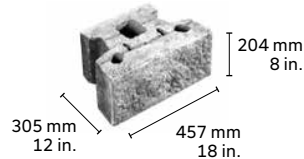

STRAIGHT CAPPING UNIT

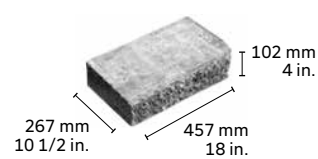

All units are packaged separately. Compact units include fibreglass pins.

LAYING PATTERN

RUNNING BOND PATTERN

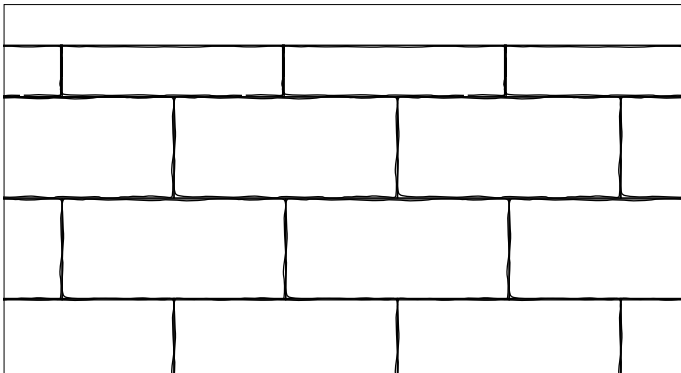

The information contained in these technical documents is supplied for information purposes only. Any application of the information is the sole responsibility of the installer. The installer must ensure that the installation and use of retaining wall projects comply with local regulations and code requirements. A qualified engineer must be consulted for final design for construction purposes. Oldcastle Building Products Canada, Inc. and its affiliates cannot be held responsible for the improper use of information contained in these technical documents.

KEYSTONE WALL - INSTALLATION

BASIC INSTALLATION

If you have any questions about installation, please contact your Permacon representative.

BURYING AND LAYING BED

- 1 - Excavate a space large and deep enough to create the laying bed and install the Keystone wall units to be buried
 - The laying bed must be at least the width of one unit plus 6 inches on each side, as shown in the diagram below
 - Depending on the type of installation, the minimum height of the wall to be buried is either 200 mm - 8 in., or the total height of the wall divided by 10 (whichever is greater)
- 2 - Fill the laying bed with 0 to 20 mm - 0 to 3/4 in. compacted stone
Refer to Step 3 in the Wall Installation section of the Installation Guide

COMPACTED GRANULAR FOUNDATION

INSTALLING FIRST ROW

- 1 - Lay the compact Keystone wall units side by side on the laying bed
- 2 - Ensure that all compact units are installed against each other and level to one another. There should be no holes at the sides or bottom of the units.
 - Using a mallet, **gently** tap the ends of the compact units so that they are straight with the ground and the other wall units

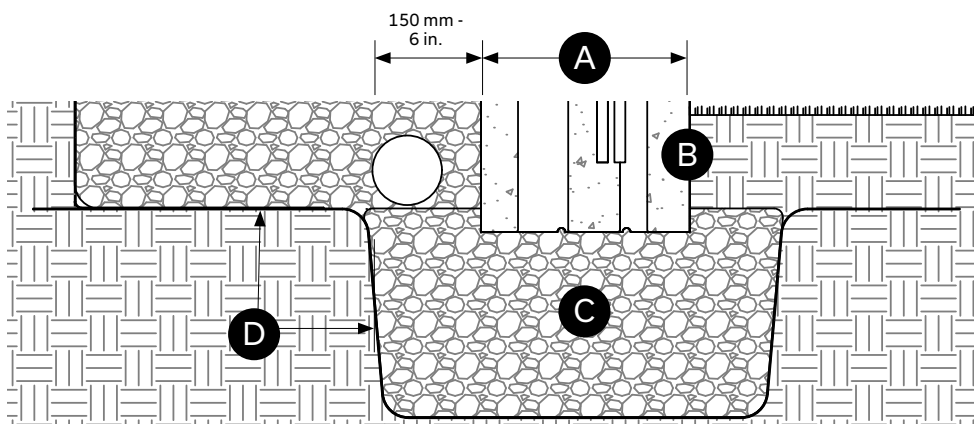

- A Wall dimensions
- B Front face
- C Compacted granular foundation:
Depth: 150 mm - 6 in.
Width: 610 mm - 24 in.
- D Excavation limits

Buried depth recommendation: For small Keystone gravity walls, a minimum of 6 inches embedment is required.

FIBREGLASS PINS

WALL AND PIN INSTALLATION

Insert the fibreglass pins of the compact unit into the two appropriate holes.

- Depending on the required setback, place the pins in the front pin cores closest to the unit textured face (1° setback) or in the back pin cores closest to the inner cavity (9° setback). If the holes in which the pins are inserted are interchanged from row to row, the wall will have a 4° setback.

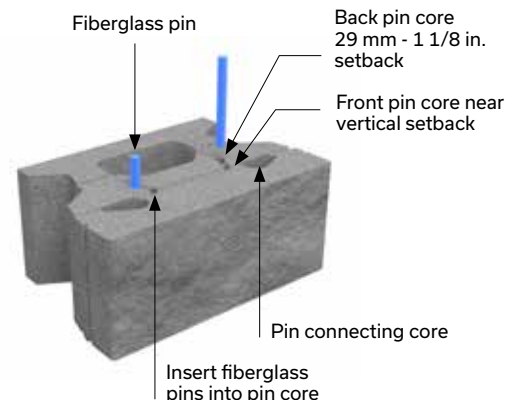

KEYSTONE WALL - INSTALLATION

ANCHOR PIN SYSTEM

KEYSTONE UNIT

Straight face compact - View from above

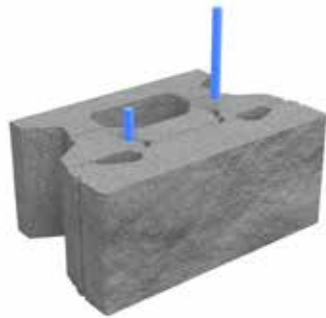
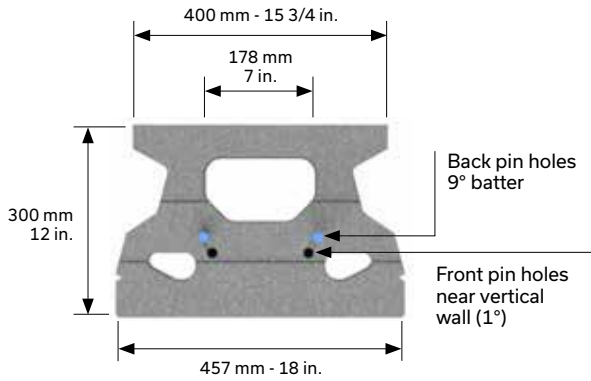

Insert connecting pin into pin holes

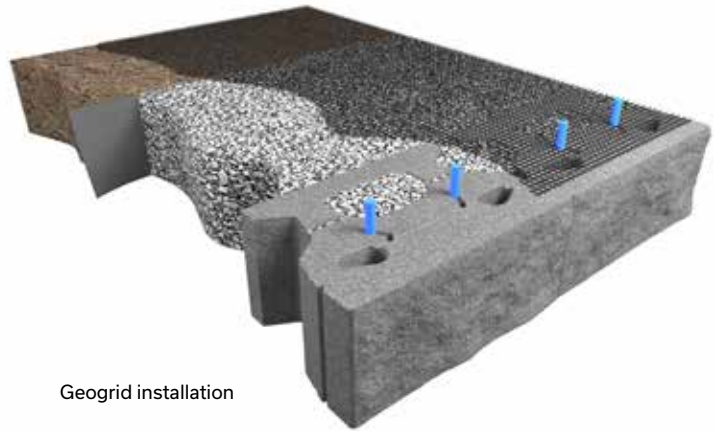

Geogrid installation

SETBACK OPTIONS

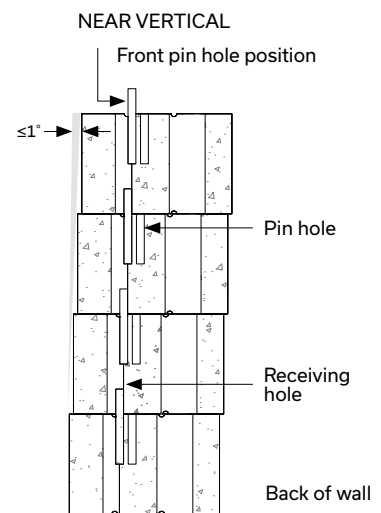
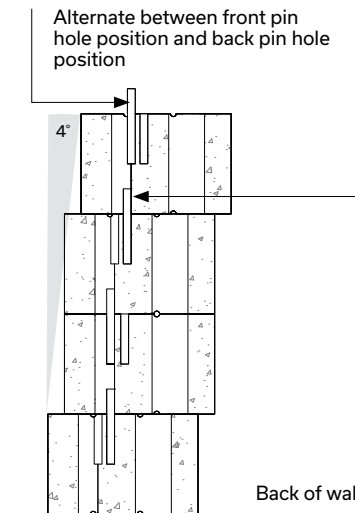
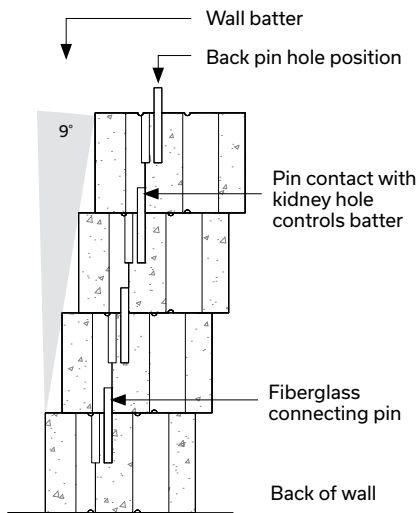

KEYSTONE WALL - INSTALLATION

DRAINAGE PIPE DETAILS

To ensure proper drainage and durability over the years, it is critical to install a drain behind the wall.

- 1 - Install the drainage pipe behind the first row of Keystone wall units
- 2 - Fill this area with 20 mm - 3/4 in. crushed drainage stone at least 300 mm - 12 in. wide while covering the drainage pipe

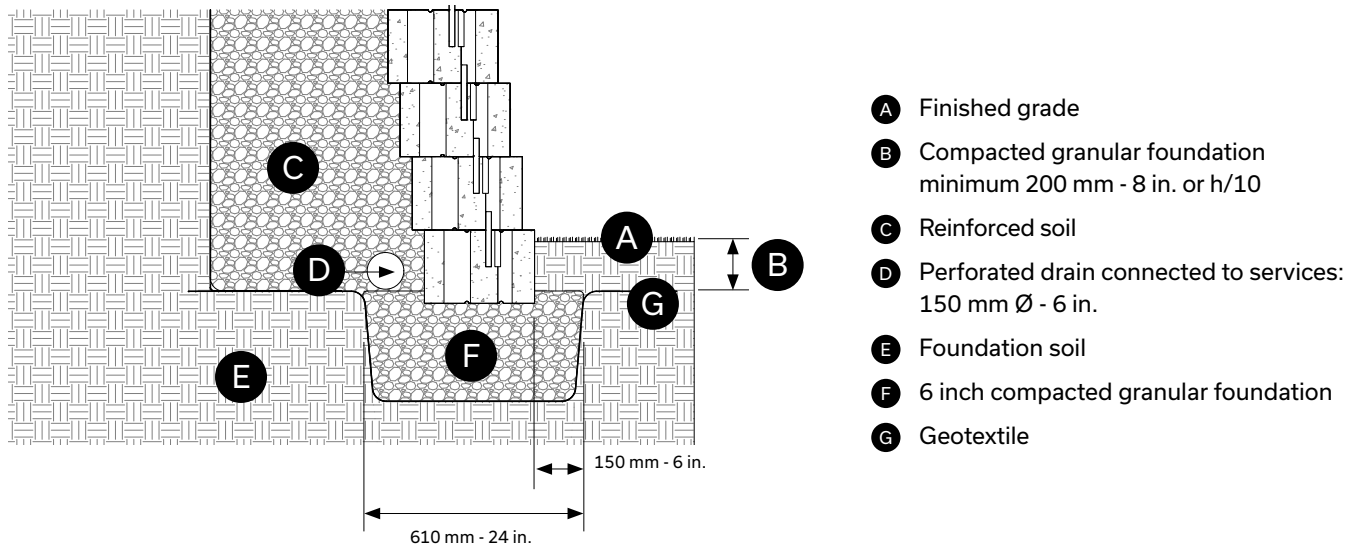

UNIT INSTALLATION

TOP ROWS

Once the first row has been laid on the compacted granular foundation and the drainage system installed, the remaining rows of Keystone units can be installed.

- 1 - Align the pin cores of the compact units above the fiberglass pins of the first row
- 2 - Lay the units, making sure that the pins of the lower row are in the cores of the upper unit
- 3 - Repeat steps #1 and 2 for all units in the row
- 4 - Make sure all units are installed against each other and level to one another. There should be no space in the sides or bottom of the units.
 - Using a mallet, **gently** tap the ends of the units so that they are straight with the ground and the other wall units
- 5 - Repeat steps #1 to 4 for all rows of the wall, inserting geogrids where indicated

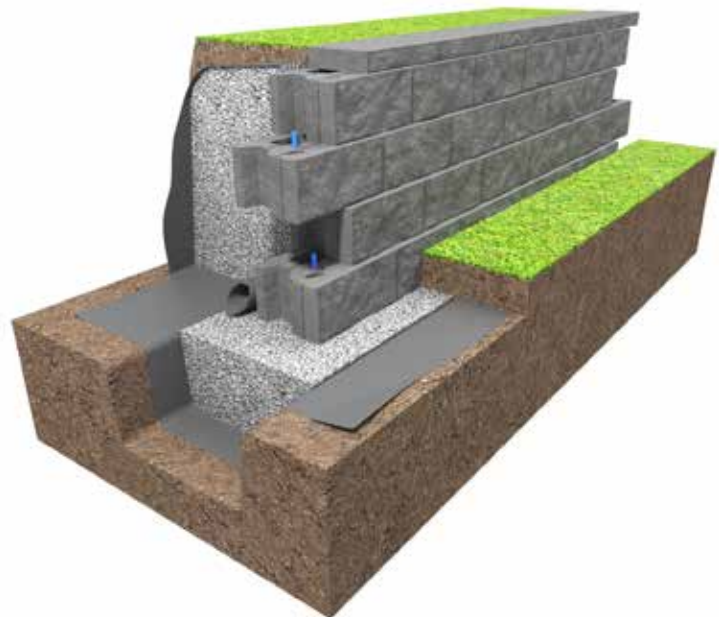

UNIT CONNECTION - CONT'D

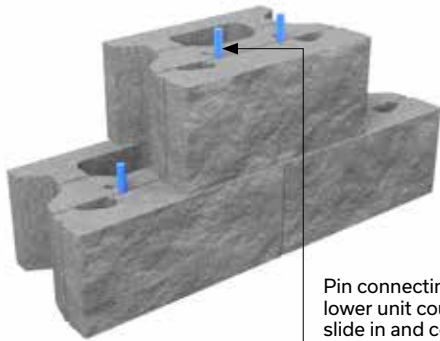

Pin connecting of upper unit course to lower unit course. Core allowing pin to slide in and complete unit connection.
Note: Place two Keystone fiberglass pins in each unit

PIN CONNECTION - near vertical setback section

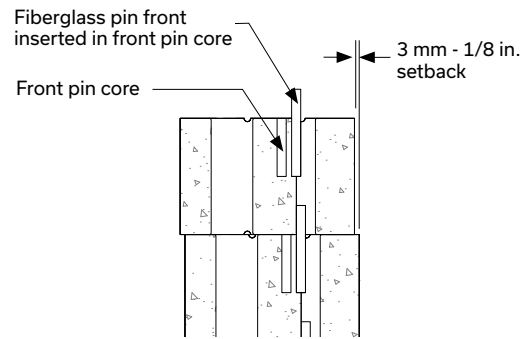

WALL UNIT TO WALL UNIT CONNECTION

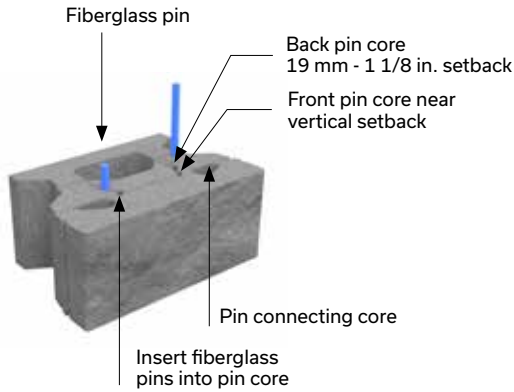

PIN CONNECTION

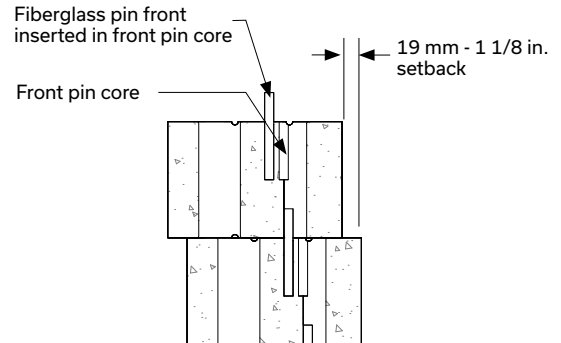

KEYSTONE WALL - INSTALLATION

INSTALLING GEOGRIDS

The first geogrid must be installed above the second row from the laying bed.

1 - Cut the geogrid to required dimensions

2 - Place it on the Keystone wall units

- The strongest direction of the geogrid should be installed perpendicular to the direction of the wall
- The pins are inserted into the cores in the geogrid

3 - Ensure the geogrid covers the entire surface

4 - If several geogrids are used lengthwise, make sure they don't overlap but are placed side by side without leaving any gaps.

5 - Continue building the wall (see *Unit Connection - Top Rows* section)

GEOGRID CONNECTION

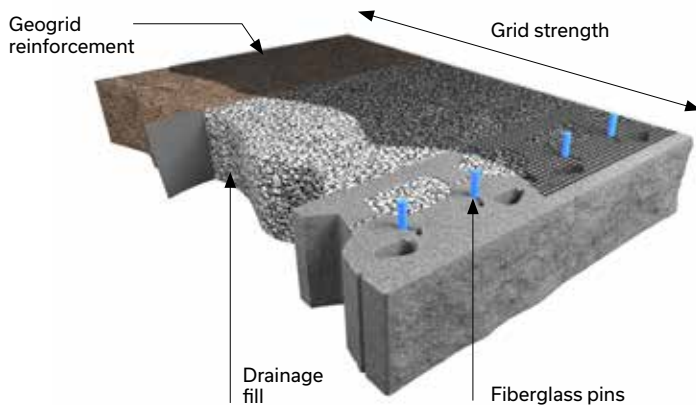
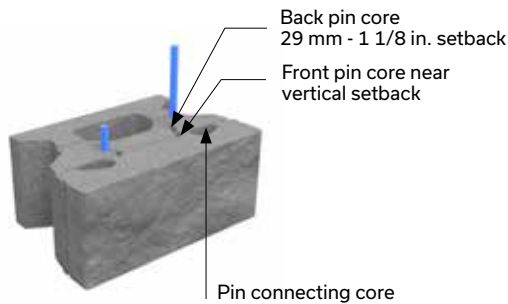

Grid and pin connection -
near vertical setback section

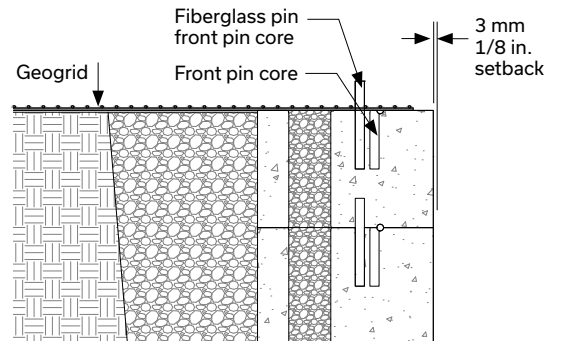

Grid and pin connection -
29 mm - 1 1/8 in. setback section

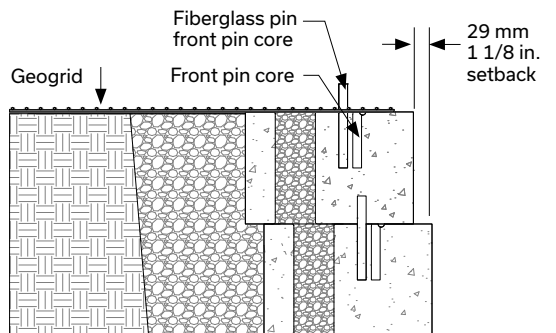

Design and installation may vary according to project and site. Please consult your Permacon representative. All project-specific information on elevation, depth, strength, soil types, etc. should be provided by an expert, such as an engineer or architect.

KEYSTONE WALL - INSTALLATION

CAPPING

SECURING THE CAPPING UNITS

Once the wall has been installed to the desired height, the capping units must be installed.

- 1 - Using Techniseal® concrete adhesive, glue the clean, dry Keystone capping units to the last row of Keystone compact units, still in running bond pattern
- 2 - Make sure all capping units are level with no gap between units

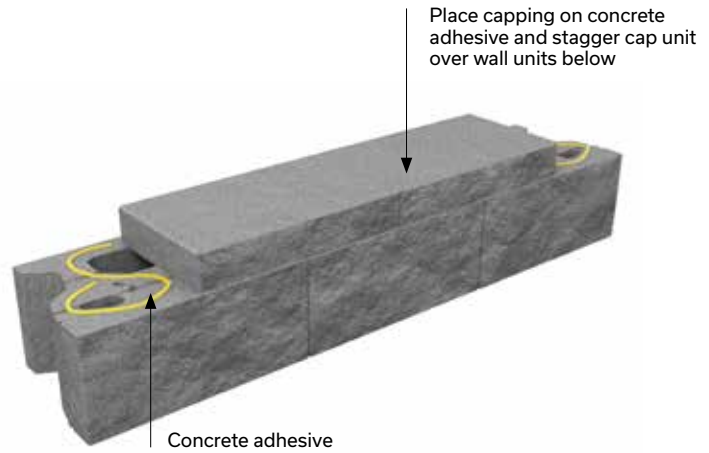

CROSS-SECTIONS

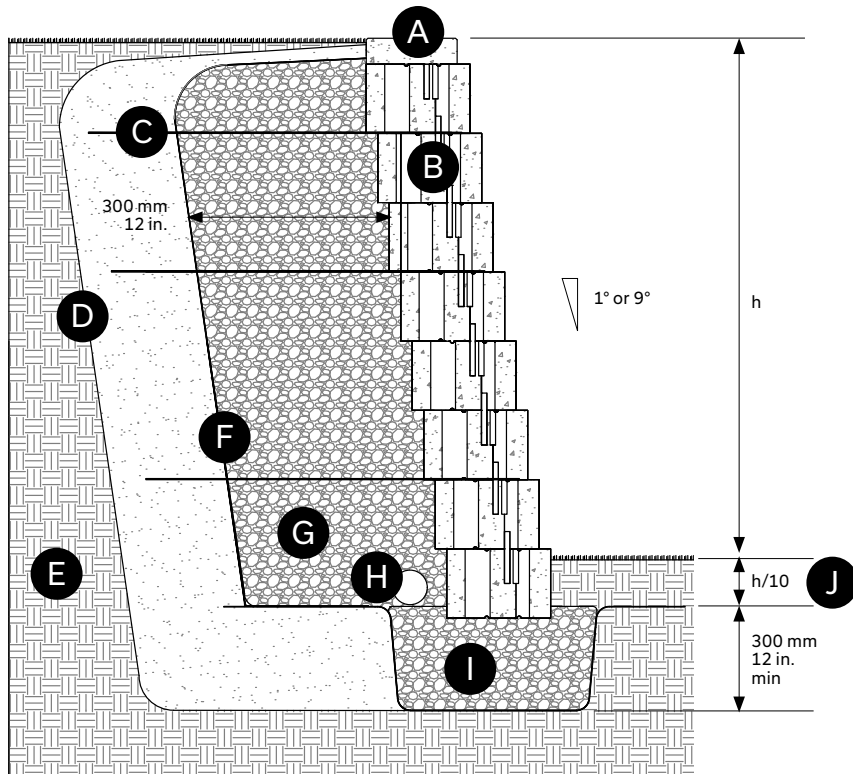

- Ⓐ 102 mm - 4 in. capping unit
- Ⓑ 200 mm - 8 in. Keystone unit
- Ⓒ Typical geogrid (for engineering, contact your Permacon sales representative)
- Ⓓ Excavation slope
- Ⓔ Existing soil
- Ⓕ Geotextile
- Ⓖ Clean stone 20 mm - 3/4 po
- Ⓗ Perforated drain connected to services: 150 mm Ø - 6 in.
- Ⓘ Compacted granular foundation 0 to 20 mm - 0 to 3/4 in.
- ⓵ Minimum buried depth largest 200 mm - 8 in. or h/10

KEYSTONE WALL - INSTALLATION

CROSS-SECTION - 9° SETBACK WALL - NO SURCHARGE, NO SLOPE

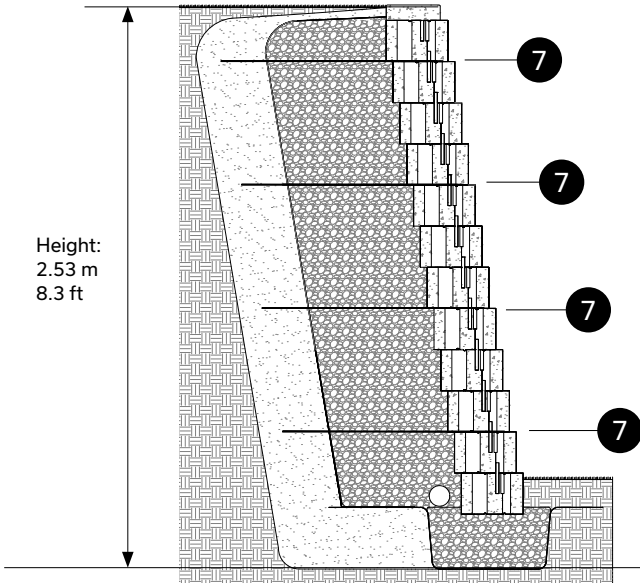

Length of the geogrid: 2.13 m - 7 ft

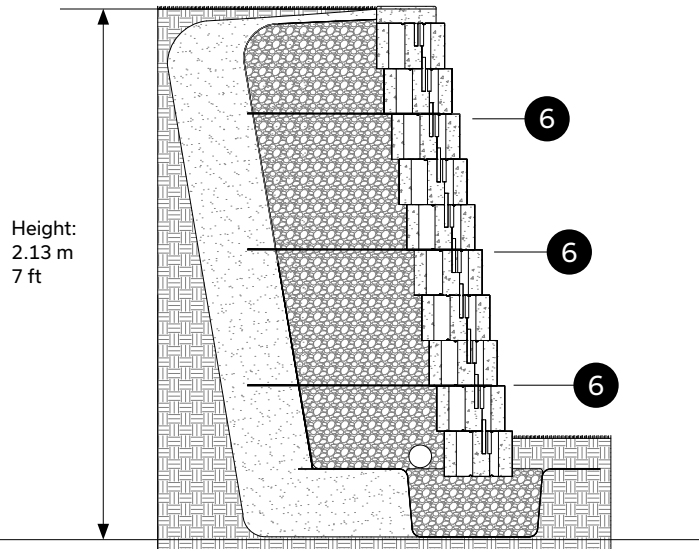

Length of the geogrid: 1.83 m - 6 ft

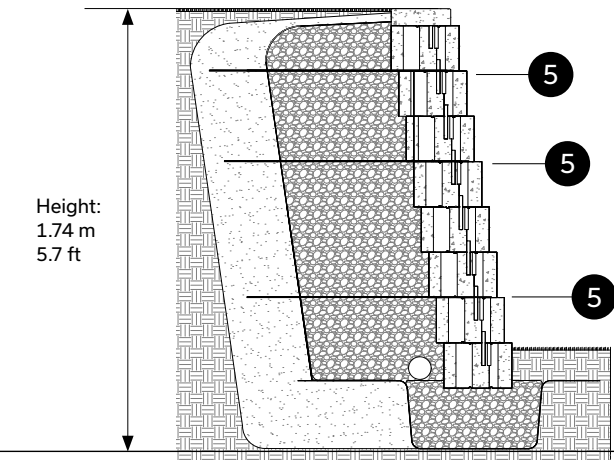

Length of the geogrid: 1.52 m - 5 ft

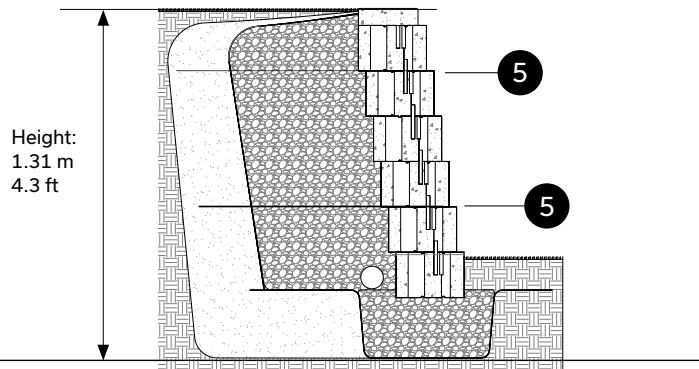

Length of the geogrid: 1.52 m - 5 ft

Maximum wall heights assume there is no surcharge behind the wall and no slope, and that the wall retains sand or gravel ($\phi = 30$ degrees, $\gamma = 22$ kN/m³).

KEYSTONE WALL - INSTALLATION

CROSS-SECTION - 1° SETBACK WALL - NO SURCHARGE, NO SLOPE

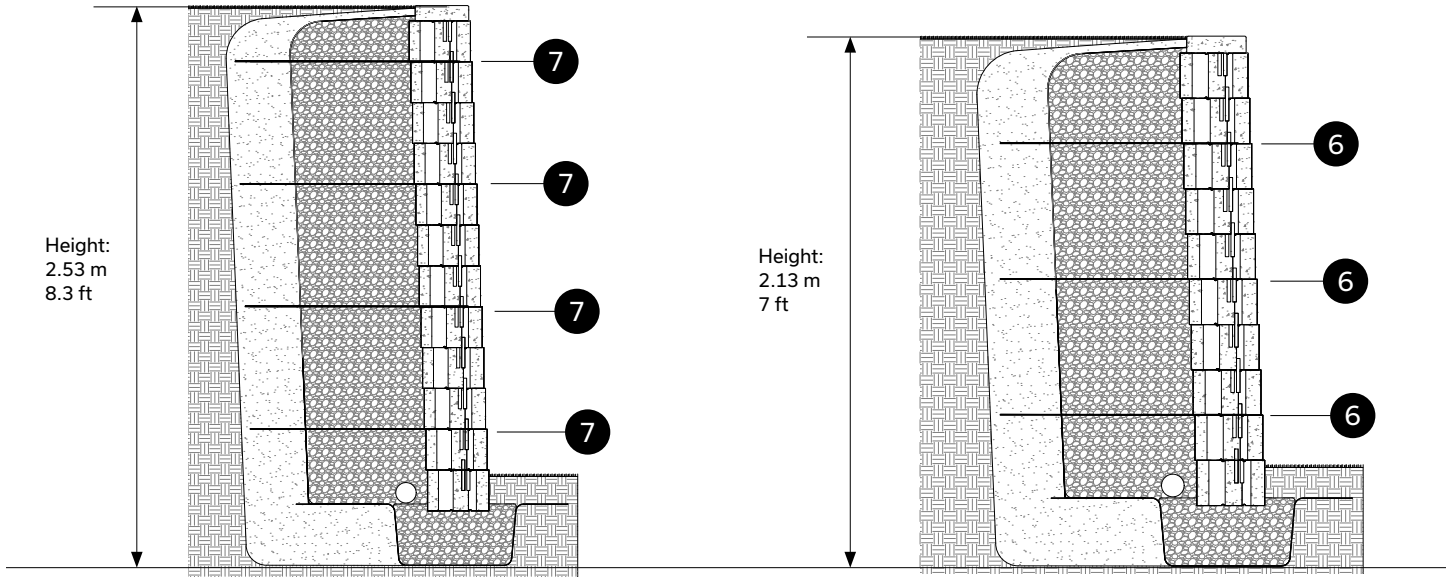

Length of the geogrid: 2.13 m - 7 ft

Length of the geogrid: 1.83 m - 6 ft

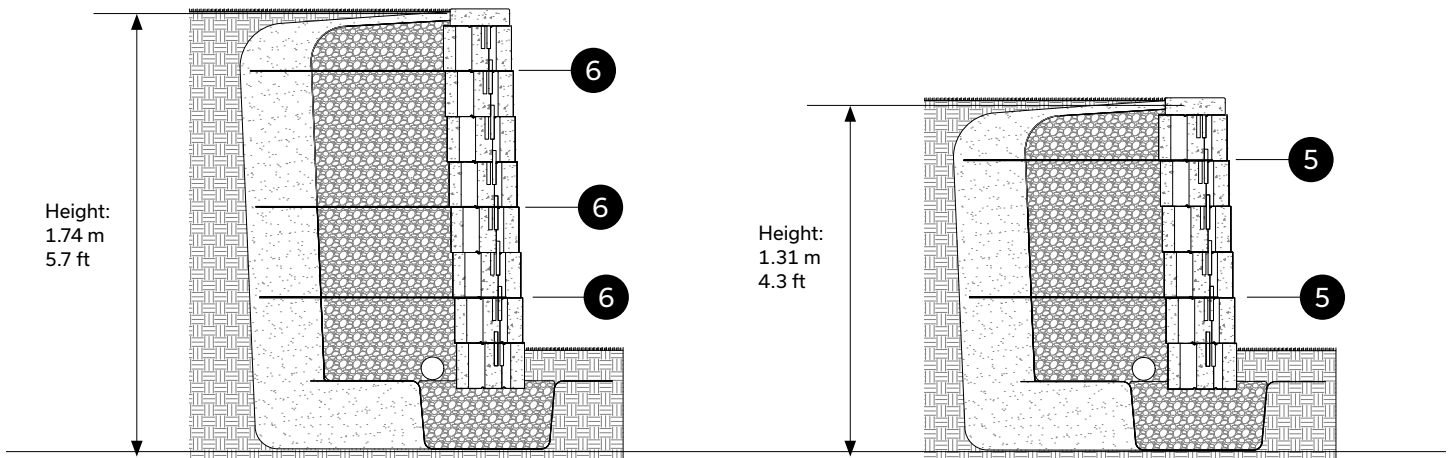

Length of the geogrid: 1.52 m - 5 ft

Length of the geogrid: 1.52 m - 5 ft

Maximum wall heights assume there is no surcharge behind the wall and no slope, and that the wall retains sand or gravel ($\phi = 30$ degrees, $\gamma = 22$ kN/m³).

KEYSTONE WALL - INSTALLATION

CREATING AN OUTSIDE CORNER

To create an outside corner, use Keystone corner units.

- 1 - Install the corner units as shown in the diagram below
 - Make sure both textured sides face the outside of the wall (visible side)
- 2 - At the top row, install the corner unit, alternating the textured faces with those of the bottom row, to maintain the running bond pattern and avoid vertical joint lines
- 3 - At the third row, stagger the corner units so that the vertical joints are the same as in the first row
- 4 - Repeat steps #1 and 2 for each row of Keystone wall

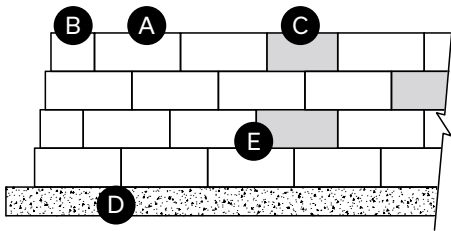
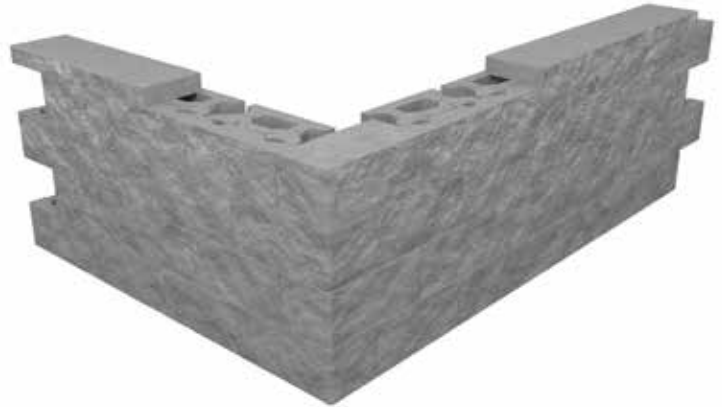

- A Keystone compact unit
- B Keystone corner unit
- C Keystone compact cut unit (both sides)
- D Compacted granular foundation
- E Full units in base course

FENCE OR GUARDRAIL

A fence or guardrail is easily installed behind the Keystone wall, as shown in the following diagram:

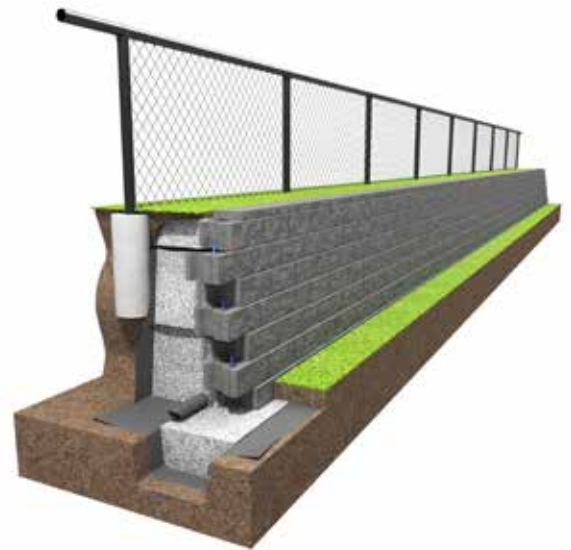
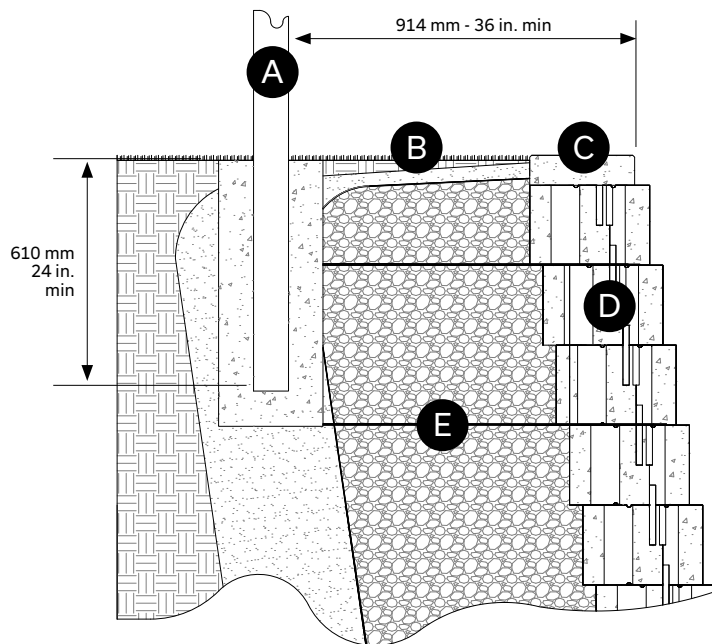

- A Fence post
- B Finished grade
- C Keystone capping unit
- D Keystone wall unit
- E Geogrid

Curbs and Accessories Index

Curbs

Typical Cross-Section	283
Celtik Curb	284

Capping

Pool Capping Cross-Section	285
Existing Concrete Step Overlay with Mondrian Plus	286

Steps

Steps Installation - Typical Details	287
Mega Melville Plus and Mega Lafitt Plus Steps	288
Marina 60 Capping (Step option)	289
Celtik 15 inch Modular Step System	290

Mirage Porcelain Tiles

Quartziti 2.0	291
Noon	291

PACKAGING

For product packaging information, please refer to our Product Data Guide on our website.



English
Quebec



English
Ontario

NOTE: Please note that only curbs and accessories with specific notes are included in the guide. For information on our entire product line, please see our product guide.

Curbs

TYPICAL INSTALLATION

TYPICAL PAVER INSTALLATION WITH MELVILLE CURB, LAFITT CURB OR CELTIK CURB

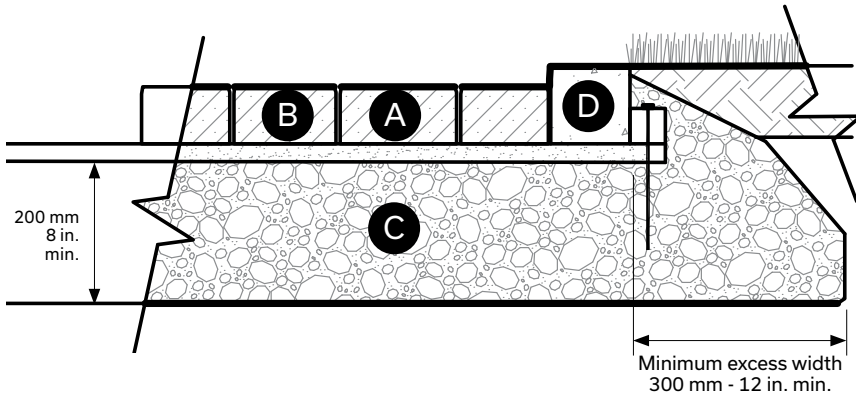

- Ⓐ Paving stones
- Ⓑ Installation bed 25 mm - 1 in. (concrete sand)
- Ⓒ Compacted granular foundation: 0 to 20 mm - 0 to 3/4 in.
- Ⓓ Curb

TYPICAL PAVER INSTALLATION WITH NOVO CURB

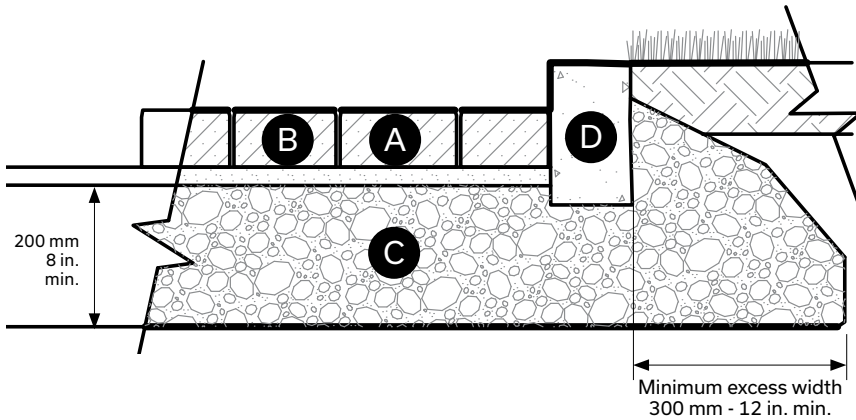

- Ⓐ Paving stones
- Ⓑ Installation bed 25 mm - 1 in. (concrete sand)
- Ⓒ Compacted granular foundation: 0 to 20 mm - 0 to 3/4 in.
- Ⓓ Novo curb

Celtik® Curb

SPECIFIC DETAILS



UNITS

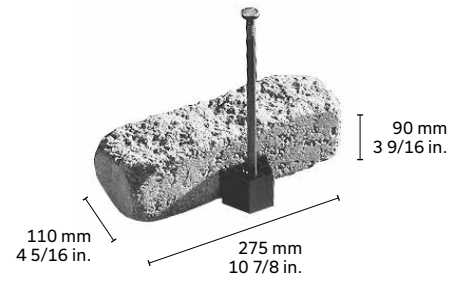
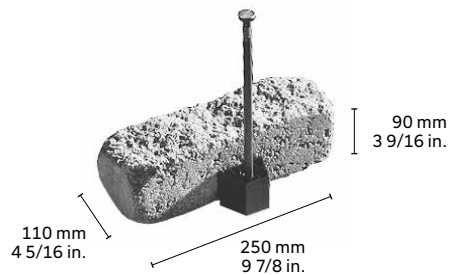
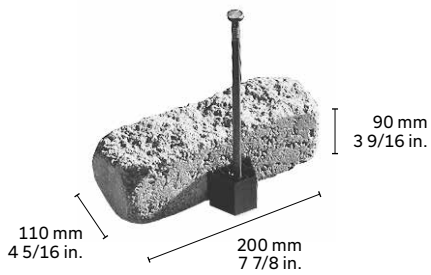

C3-ANCHORS

NOTE: in order to facilitate orders by half layer (13 lin.ft.) each row must include 2 boxes of anchors. Each box contains 16 C3-anchors and 16 nails.

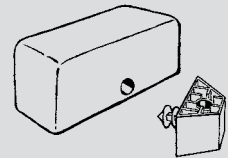

LAYING IDEAS

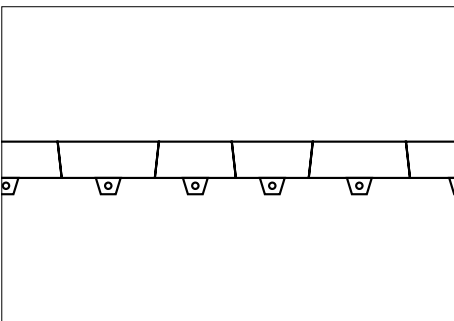

For a straight line curb, use alternating angled curb units.

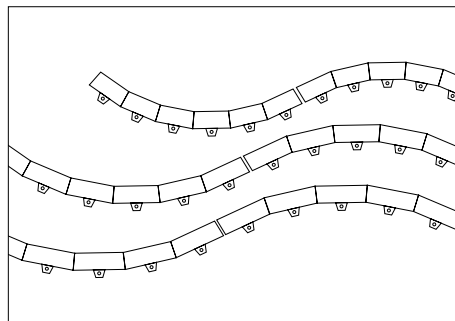

For a concave or convex curve, lay curb units in the same direction.

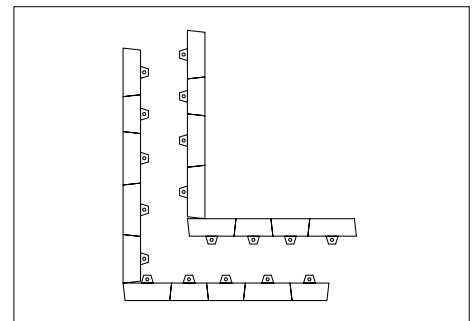

For a 90° corner, simply align curb units at this angle.

Laguna, Leno and Marina Pool Capping

CROSS-SECTION - POOL WITH PAVERS

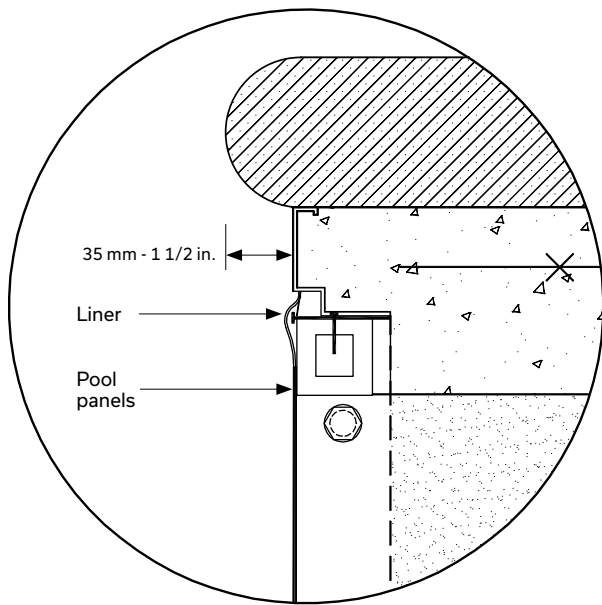
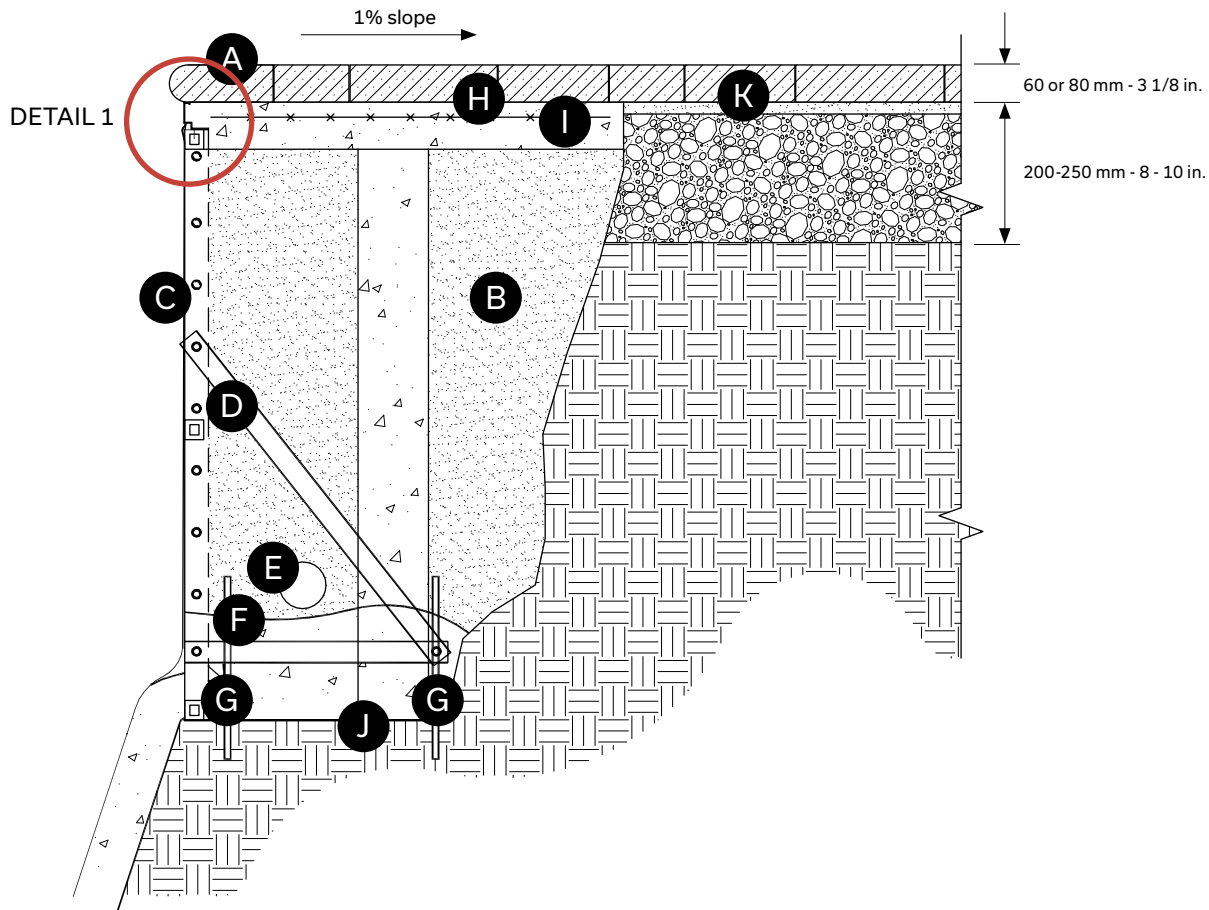

DETAIL 1

- Ⓐ Pool capping and pavers glued with Techniseal concrete adhesive or mortar
- Ⓑ Sand
- Ⓒ Pool panels
- Ⓓ Reinforcement bars
- Ⓔ Perforated drain: 100 mm Ø - 4 in.
- Ⓕ Concrete footing 200 x 200 mm - 8 x 8 in.
- Ⓖ Metal rod 10 mm - 3/8 in.
- Ⓗ Concrete deck 1 m - ± 39 in. wide x 100 mm - 4 in. thick
- Ⓘ Wire mesh 150 x 150 mm - 6 - 6 in. x 9 ml (G)
- ⓵ Concrete Sonotube 150 mm - 6 in. Ø
- Ⓚ Bedding course 25 mm - 1 in.

Overlay of Existing Concrete Step with Mondrian® Plus Capping

SPECIFIC DETAILS



UNIT

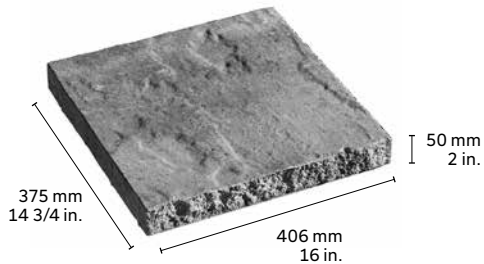

CROSS-SECTION - OVERLAY OF EXISTING CONCRETE STEPS

MONDRIAN PLUS 50 CAPPING AND SLABS

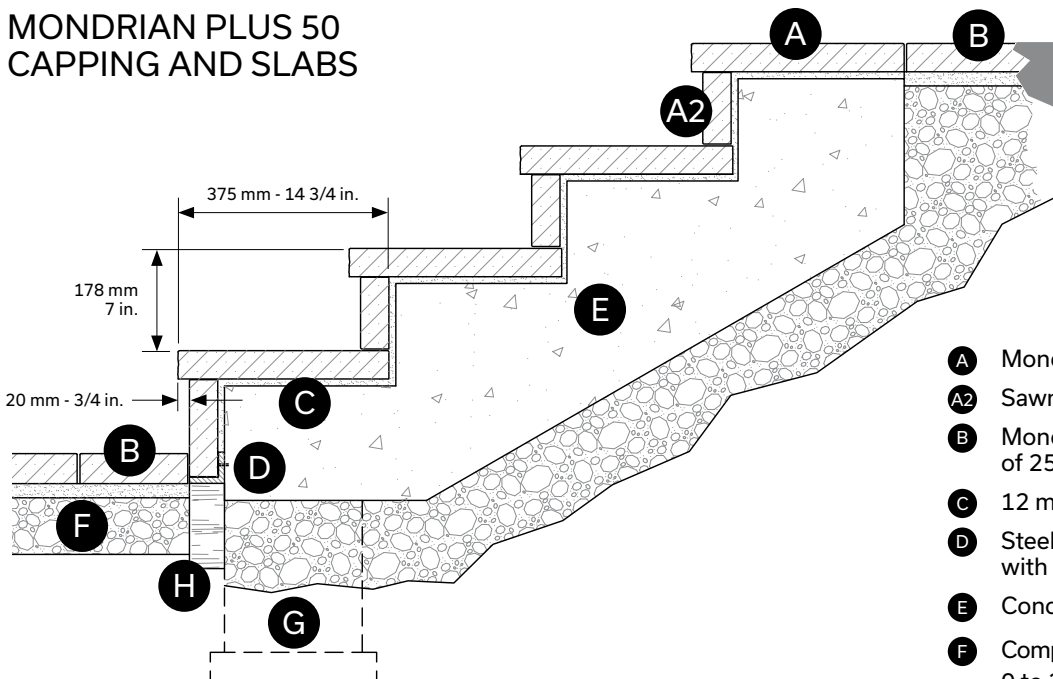

- Ⓐ Mondrian Plus capping unit
- Ⓐ2 Sawn Mondrian Plus unit
- Ⓑ Mondrian 50 slab (3 sizes) on a laying bed of 25 mm - 1 in.
- Ⓒ 12 mm - ± 1/2 in. adhesive or mortar
- Ⓓ Steel iron angle fixed at the concrete slab with anchorings
- Ⓔ Concrete staircase
- Ⓕ Compacted granular foundation: 0 to 20 mm - 0 to 3/4 in.
- Ⓖ Concrete Sonotube (sole safe from freezing)
- Ⓗ Rigid insulation

Steps

TYPICAL INSTALLATION

BUILDING STAIRS WITH MEGA LAFITT PLUS

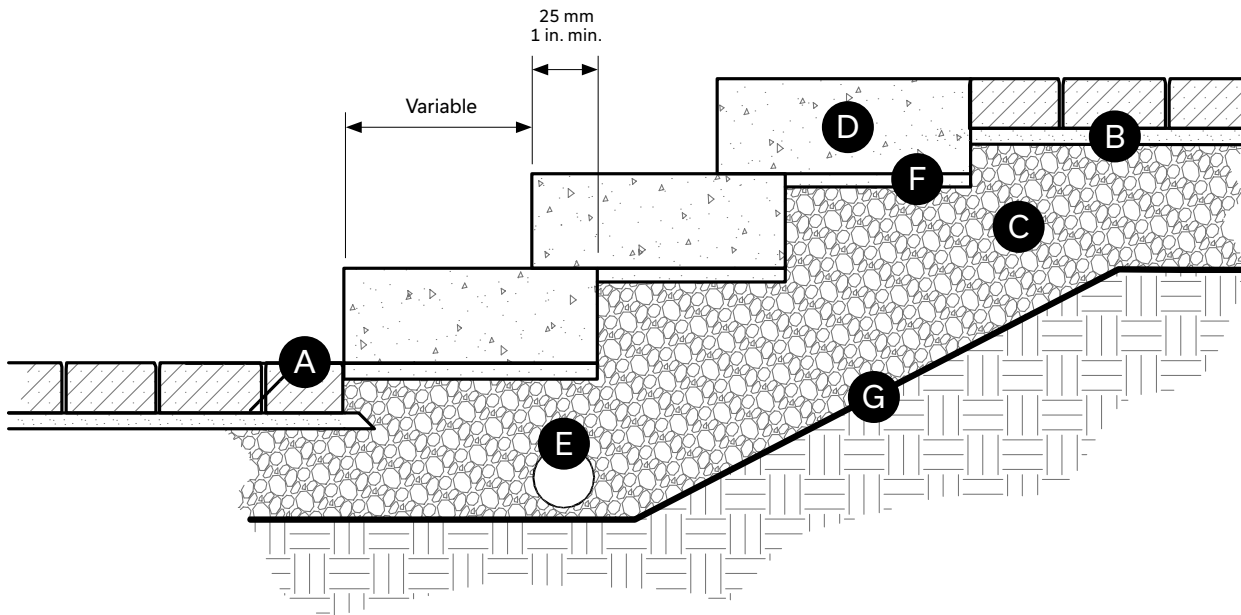

- A** Concrete pavers
- B** Laying bed 25 mm - 1 in.
- C** Compacted granular foundation: 0 to 200 mm - 0 to 3/4 in.
25 cm - 10 in. thick: sandy soil
40 cm - 16 in. thick: clay soil
- D** Mega Lafitt Plus step
- E** Perforated drain: 100 mm Ø - 4 in. connected to services
- F** 12 mm - 1/2 in. maximum laying bed (if necessary) must be compacted
- G** Geotextile

Mega Melville Plus Steps

SPECIFIC DETAILS

STAIRS WITH MEGA MELVILLE PLUS

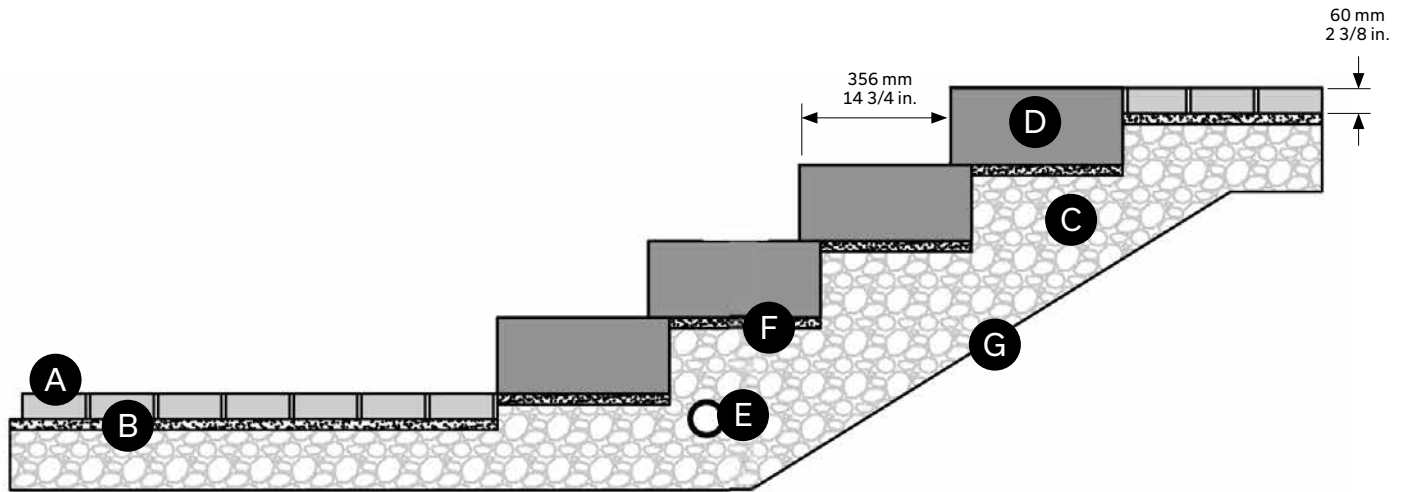

- A** Concrete pavers
- B** Laying bed 25 mm - 1 in.
- C** Compacted granular foundation: 0 to 200 mm - 0 to 3/4 in.
25 cm - 10 in. thick: sandy soil
40 cm - 16 in. thick: clay soil
- D** Mega Melville Plus step
- E** Perforated drain: 100 mm Ø - 4 in. connected to services
- F** 12 mm - 1/2 in. maximum laying bed (if necessary) must be compacted
- G** Geotextile

STAIRS WITH MEGA MELVILLE PLUS: MEGA MELVILLE PLUS STEP WITH TANDEM OR VARIO WALL

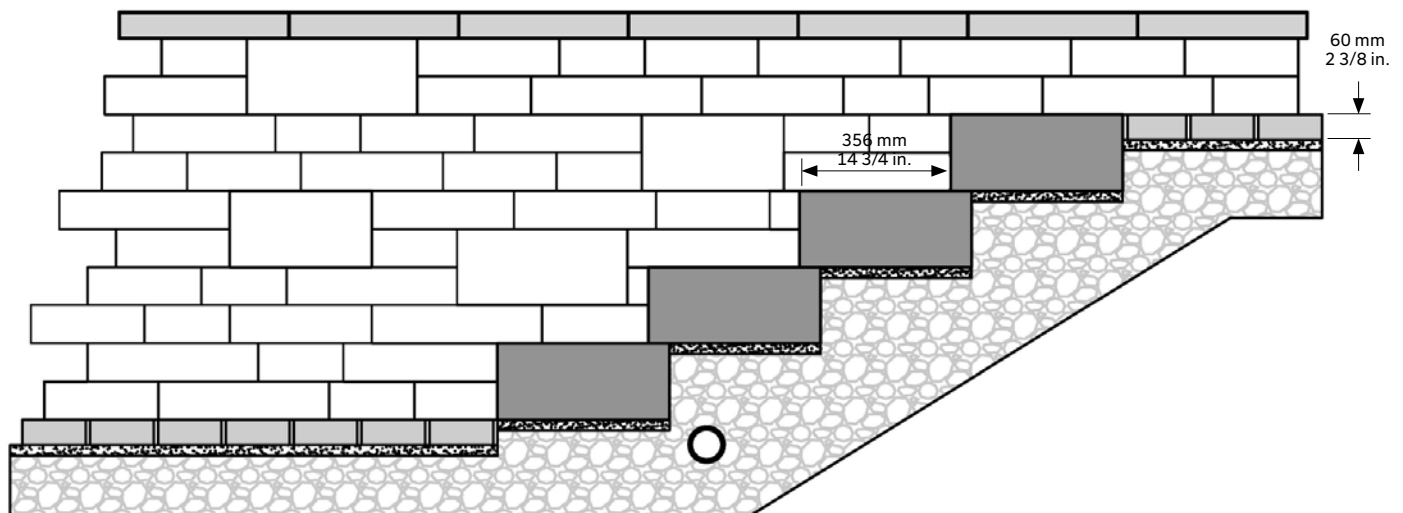

Marina 60 Capping - Step Option

UNIT

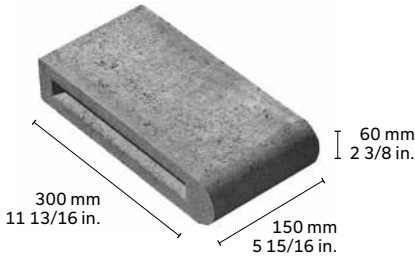

LAYING IDEAS FOR STAIRWAY OPTION

OPTION 1

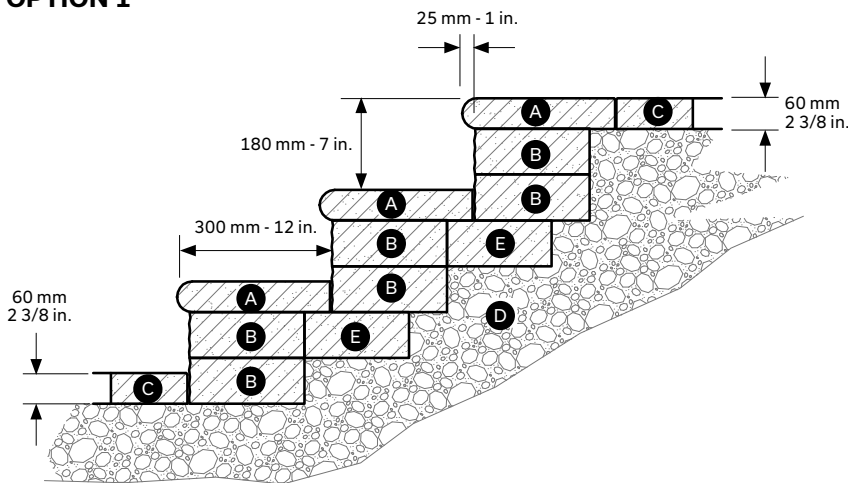

- A** Marina capping 60 x 300 x 150 mm - 2 3/8 x 11 13/16 x 5 15/16 in.
- B** Celtik 90 wall (4 sizes) of 90 x 225 mm x variable - 3 9/16 x 8 7/8 in. x variable
- C** Paver 60 mm
- D** Compacted granular foundation 0 to 20 mm - 0 to 3/4 in.
- E** Starter unit 90 x 268 x 469 mm - 3 9/16 x 10 1/2 x 18 1/2 in. or Celtik 90 wall unit

NOTE: All elements must be glued together with Techniseal concrete adhesive.

OPTION 2

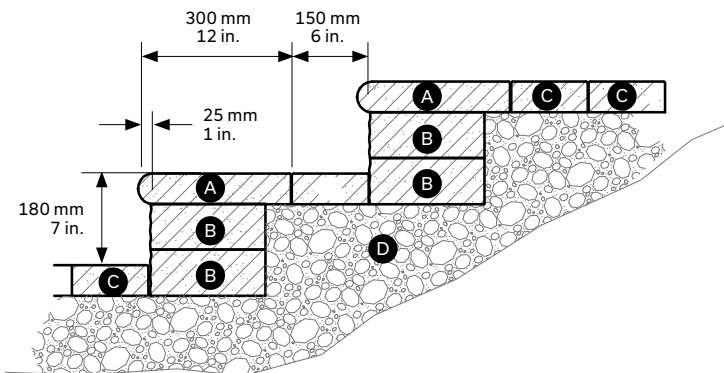

- A** Marina capping 60 x 300 x 150 mm - 2 3/8 x 11 13/16 x 5 15/16 in.
- B** Celtik 90 wall (4 sizes) of 90 x 225 mm x variable - 3 9/16 x 8 7/8 in. x variable
- C** Paver 60 mm
- D** Compacted granular foundation 0 to 20 mm - 0 to 3/4 in.

NOTE: All elements must be glued together with Techniseal concrete adhesive.

Celtik® 15 in. Modular Step System

DESCRIPTION

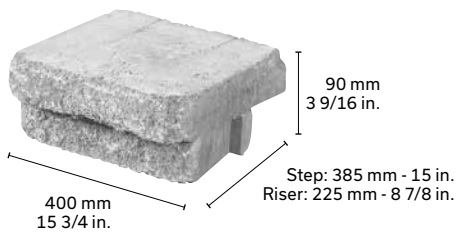

NOTE: Each set includes 1 step and 1 riser. 2 pins are included for each set.

LAYING IDEA

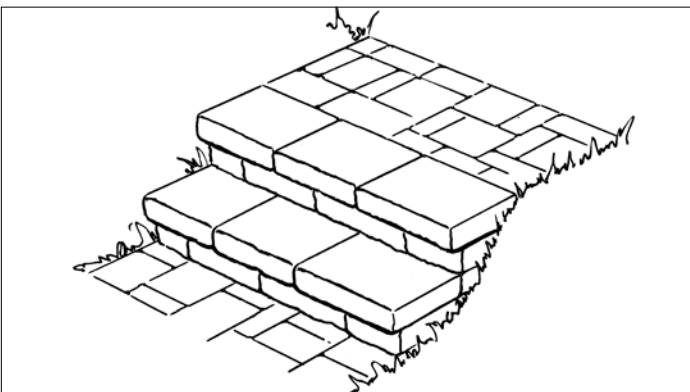

STRAIGHT STEPS

Mirage Porcelain Tiles

CROSS-SECTION - CONCRETE BASE INSTALLATION

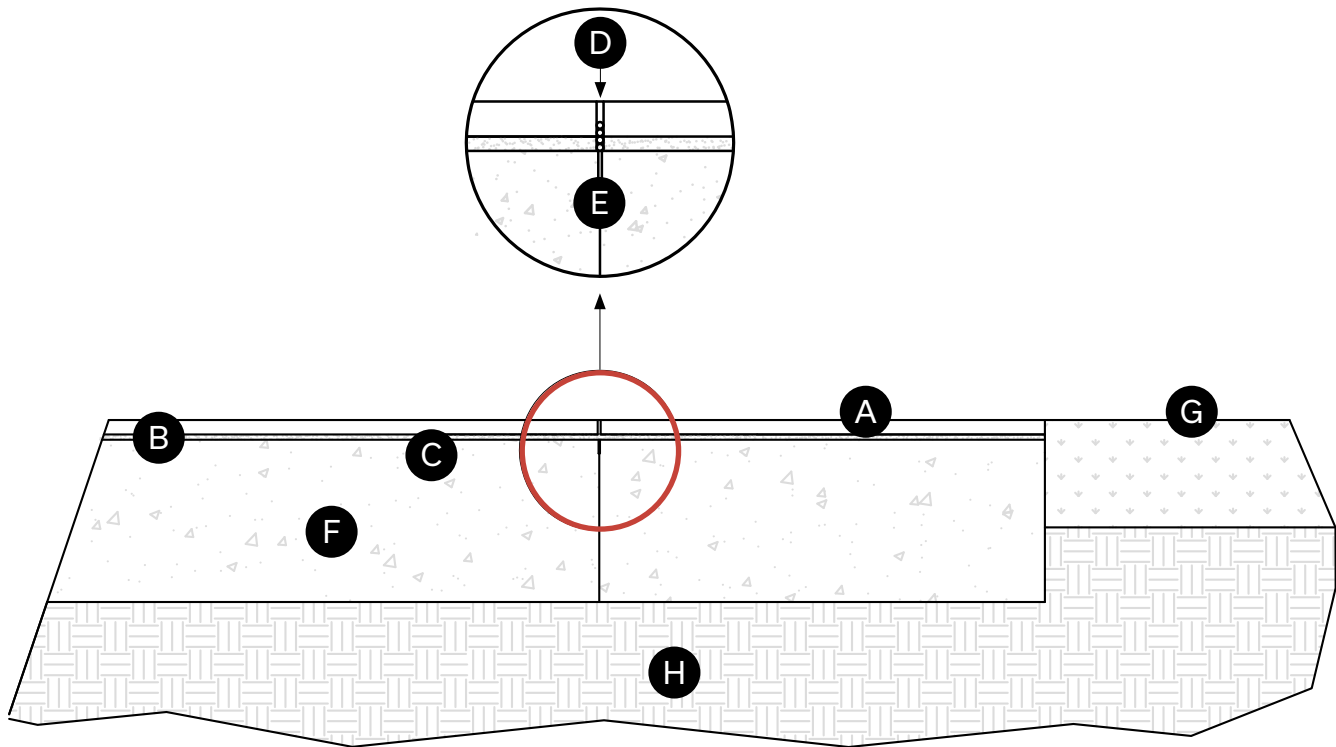

- Ⓐ Mirage porcelain tile (20 mm thickness)
- Ⓑ Joint grout for porcelain tile - 8 to 10 mm width (Ultracolor Plus or Keracolor S from Mapei or equivalent)
- Ⓒ Cementitious adhesive for porcelain tile (Kerabond T/Keralastic or Ultraflex LFT from Sika)
- Ⓓ Contraction/Control joint (architectural urethane sealant and sealant backer rod)
- Ⓔ Saw cut contraction joint. The depth of the saw cut must be a minimum of 1/4 of the thickness of the concrete slab (to induce crack beneath saw cut contraction joint).
- Ⓕ Structural concrete base 150 mm minimum thickness (design by others)
- Ⓖ Grass
- Ⓗ Existing soil with adequate bearing capacity (minimum of 100 kN/m²)

NOTES: The concrete slab must have a contraction/control joint (every 5 lin. m max). It is absolutely imperative that all contraction/control joints be located in the joint line of the installed porcelain tile and not beneath the tile. The concrete slab must be cured at least 28 days before the installation of any porcelain tiles.

Never compact porcelain tile with a plate compactor. Insure the pavement is constructed with a 2 degree slope and that it is pitched away from any building.

This installation is dedicated to a pedestrian application only. The actual structural design for light vehicular application must be performed by a qualified professional Engineer.

GENERAL NOTE: THE MIRAGE PORCELAIN TILES CAN BE CUT BY USING A TABLE WATER SAW WITH A DIAMOND BLADE SPECIALLY DESIGNED FOR PORCELAIN.

CROSS-SECTION - GRANULAR BASE INSTALLATION

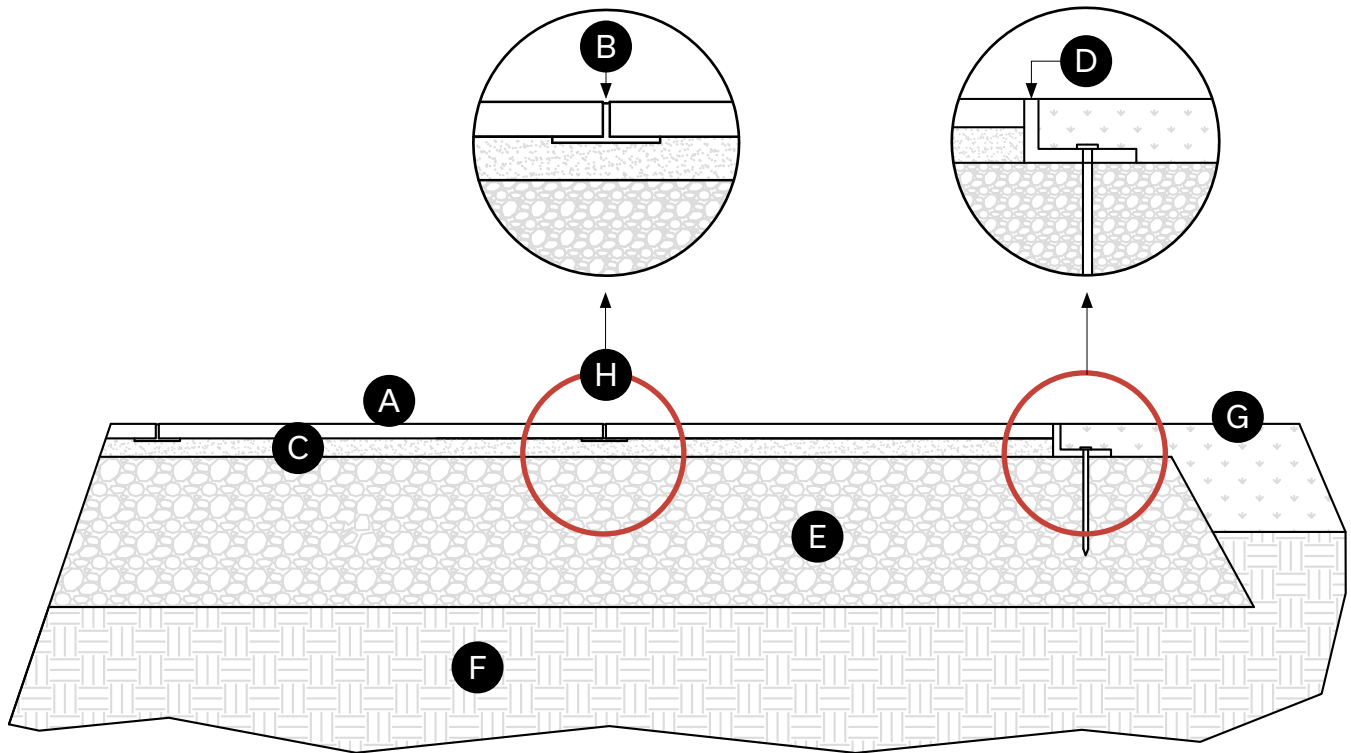

- Ⓐ Mirage porcelain tile (20 mm thickness)
- Ⓑ Joint grout for porcelain tile - 8 to 10 mm width (Ultracolor Plus or Keracolor S from Mapei or equivalent)
- Ⓒ Bedding sand 25 mm max: concrete sand (0-5 mm). Pre-compact the sand bedding course and screed to a 12 mm thickness with smooth surface
- Ⓓ Peripheral restraint system spiked into 150 to 200 mm over base area. Base material is to be over based 150 to 200 mm beyond the edge of the pavement.
- Ⓔ Crushed stone 200 to 300 mm - 0 to 20 mm compacted to 95% modified proctor
- Ⓕ Existing soil with adequate bearing capacity (minimum of 100 kN/m²)
- Ⓖ Grass
- Ⓗ Plastic spacers for Mirage porcelain tiles to insure 4 mm between tiles. 1 spacer is required at every corner.

NOTES: Never compact porcelain tile with a plate compactor. Insure the pavement is constructed with a 2 degree slope and that it is pitched away from any building.

This installation is dedicated to a pedestrian application only. The actual structural design for light vehicular application must be performed by a qualified professional Engineer.

General note: The Mirage porcelain tiles can be cut by using a table water saw with a diamond blade specially designed for porcelain.

MIRAGE PROCELAIN TILES

UNITS

QUARZITI 2.0 LARGE RECTANGLE

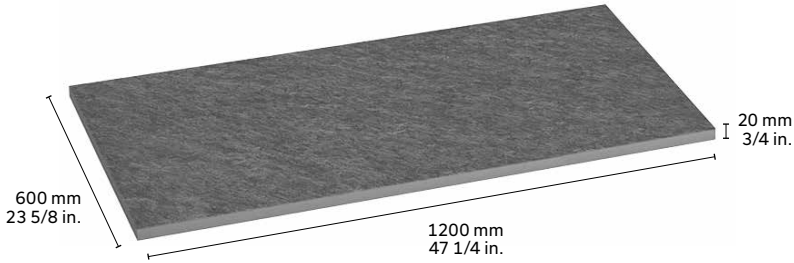

QUARZITI 2.0 LARGE SQUARE

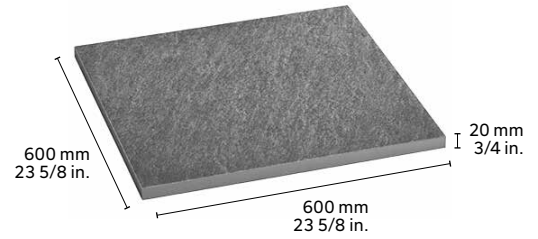

NOON

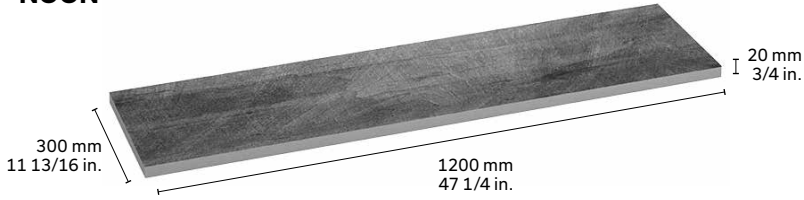

QUARZITI 2.0 POOL CAPPING

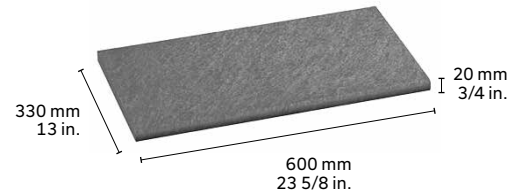

INSTALLATION ON PEDESTALS

POSITION OF THE PEDESTALS ACCORDING TO THE SIZE OF THE PORCELAIN TILES

4 PEDESTALS PER UNIT

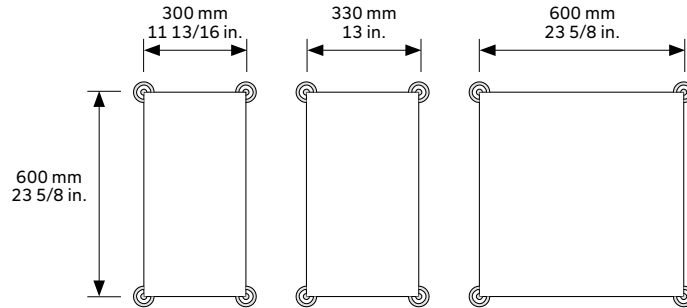

The porcelain tiles installed on a pedestal must have a galvanized steel sheet on the back.

6 PEDESTALS PER UNIT

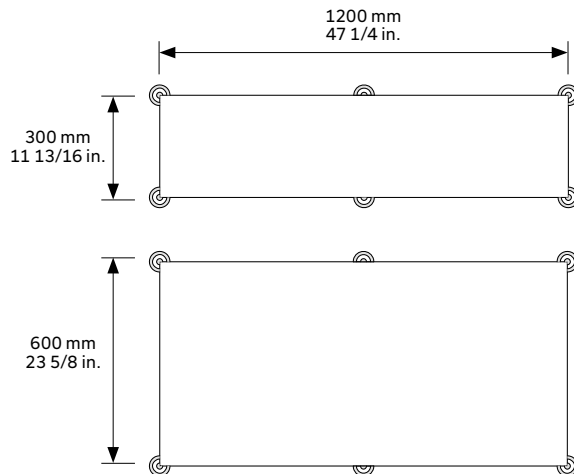

Alternative Landscaping Product Index

Artex Panel System

Tools and Safety Equipment	295
Parts List	296
Applications	297
Modularity – System and References	298
Panel Configurations	300
Outer Corner Installation	301
Inner Corner Installation	302
Joining Plate Installation	303
Stretcher Bar Installation	304
6 x 36 Panel – Capping and Accent Installation	306
Integrating Wood	309
Base preparation	313
Planter Box Details	315
Rooftop Applications	316
Handling	318
Tips and Tricks	319

Orion Firepit

Assembly	322
Installation of Orion Firepit and Spark Screen	324

PACKAGING

For product packaging information, please refer to our Product Data Guide on our website.



English
Quebec











English
Ontario

ARTEX Panel System

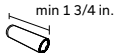

REQUIRED TOOLS

- > Drill 
- > Mallet 
- > Measuring tape 
- > Saw 
- > Level 
- > Deep hex socket 7/16 in. with 1/4 in. drive 
- > Socket adaptor 1/4 in. hex shank to 1/4 in. drive 
- > Chipping hammer 
- > Bar clamp (48 in.) 
- > Plastic shims 

SAFETY EQUIPMENT

- > Safety boots 
- > Gloves 
- > Safety glasses 
- > Mask 

PARTS LIST - CONCRETE PANELS

18 X 36 PANEL - CLOSED END

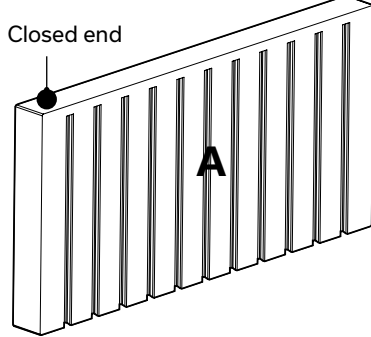

18 x 36 x 3 in. (150 lb)
457 x 914 x 76 mm (67 kg)

18 X 36 PANEL

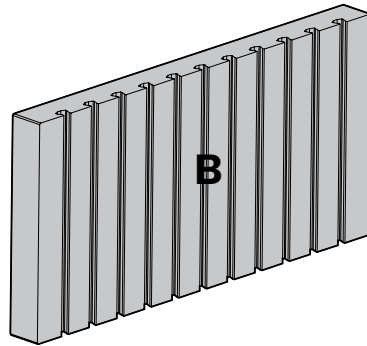

18 x 36 x 3 in. (148 lb)
457 x 914 x 76 mm (66 kg)

40 x 48 in. pallet (18 units/pallet)*

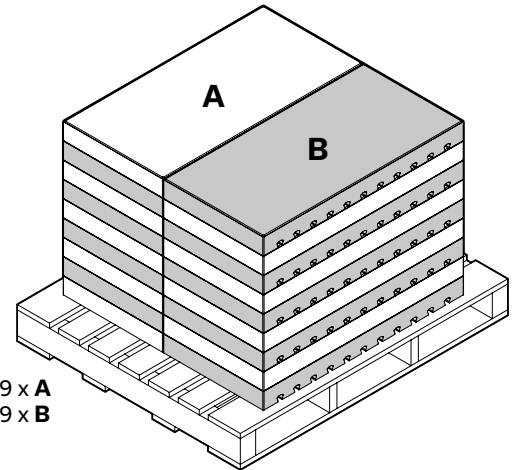

6 X 36 PANEL - CLOSED END

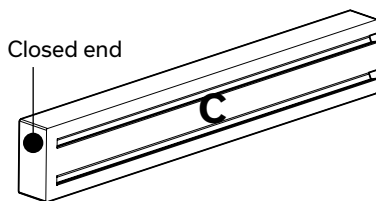

6 x 36 x 3 in. (49 lb)
152 x 914 x 76 mm (22 kg)

6 X 36 PANEL

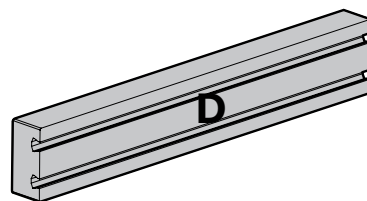

6 x 36 x 3 in. (49 lb)
152 x 914 x 76 mm (22 kg)

40 x 48 in. pallet (21 units/pallet)*

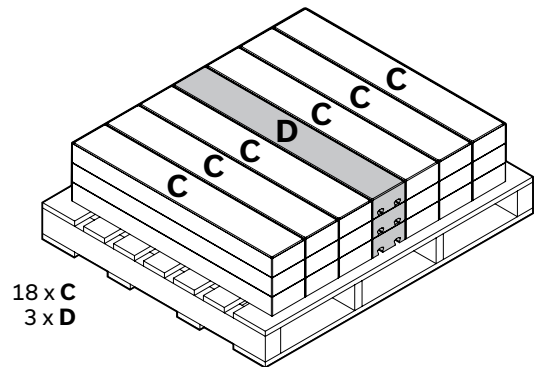

* **IMPORTANT:** 18x36 in. panels are sold in pair/layer or in full pallet only. 6x36 in. panels are sold per unit or in layer or in full pallet.

PARTS LIST - HARDWARE (STAINLESS STEEL)

ANCHOR SLIDE

1/4 in. x 20 studs and nuts
2 x 1 1/4 x 1 in. - 51 x 33 x 25 mm
100 units/box

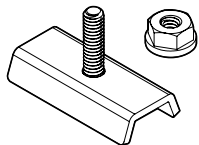

JOINING PLATE

(can be sold separately)
8 1/4 x 2 1/2 x 1 1/2 in. - 209 x 63 x 38 mm
40 units/box

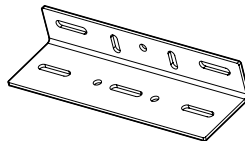

INNER CORNER

(can be sold separately)
9 x 6 x 2 1/2 in. - 232 x 155 x 63 mm
24 units/box

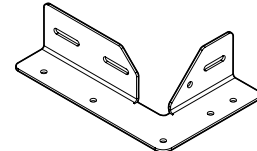

OUTER CORNER

(can be sold separately)
4 x 4 x 2 1/2 in. - 101 x 101 x 63 mm
48 units/box

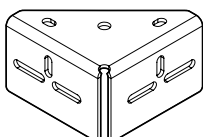

STRETCHER BAR

(can be sold separately)
36 3/4 x 1 1/4 x 1 in. - 933 x 33 x 25 mm
10 units/box

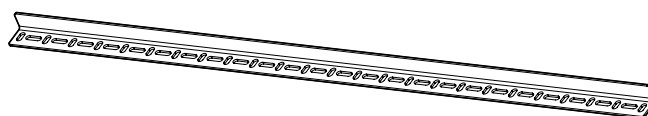

APPLICATIONS

PLANTER BOX/BENCH



PRIVACY WALL



FIRE PIT*



RAISED GARDEN



OUTDOOR KITCHEN*



COUNTER



FOR MORE APPLICATIONS REFER TO THE ARTEX IDEA BOOK :



IMPORTANT: For all complementary appliances/accessories to the ARTEX panel system, follow manufacturer's instructions/guidelines. Consult qualified services person/ experts to validate installations, repairs, safety recommendations and any other related topics.

MODULARITY - SYSTEM

18 X 36 PANEL

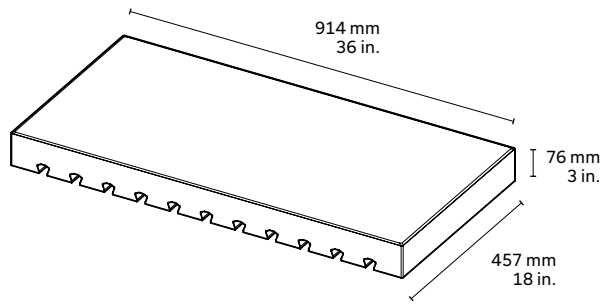

6 X 36 PANEL

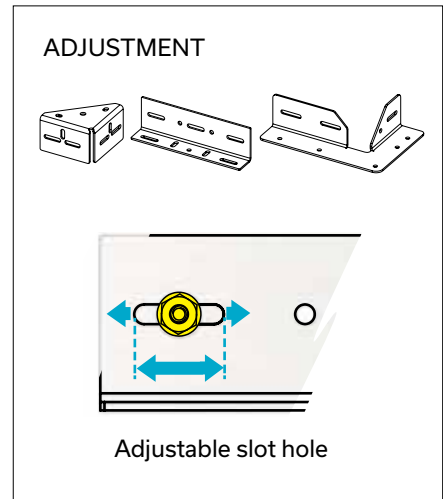
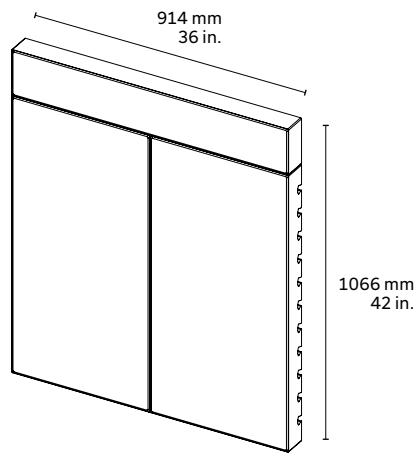
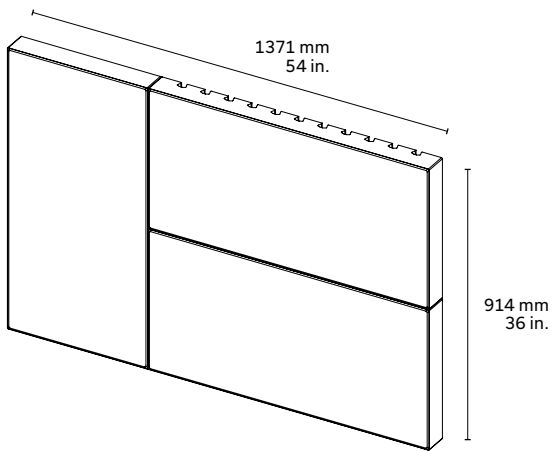
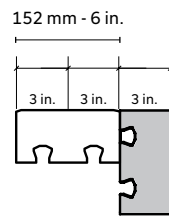
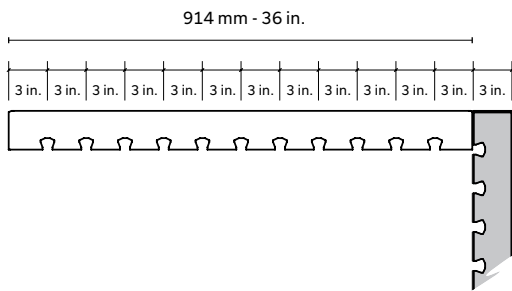
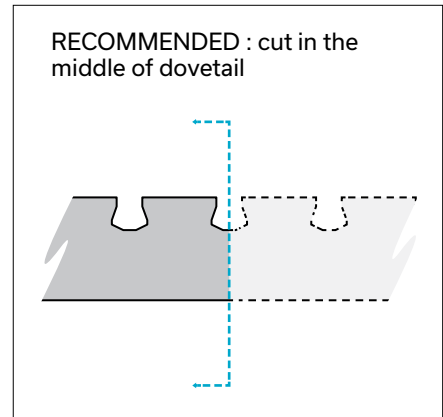
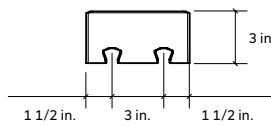
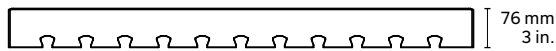
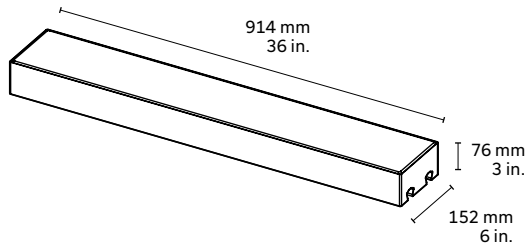

NOTE: It is recommended to design structures with overall dimensions using increments of 3 in. - 76mm.

MODULARITY - REFERENCES

KITCHEN TABLE



BAR TABLE

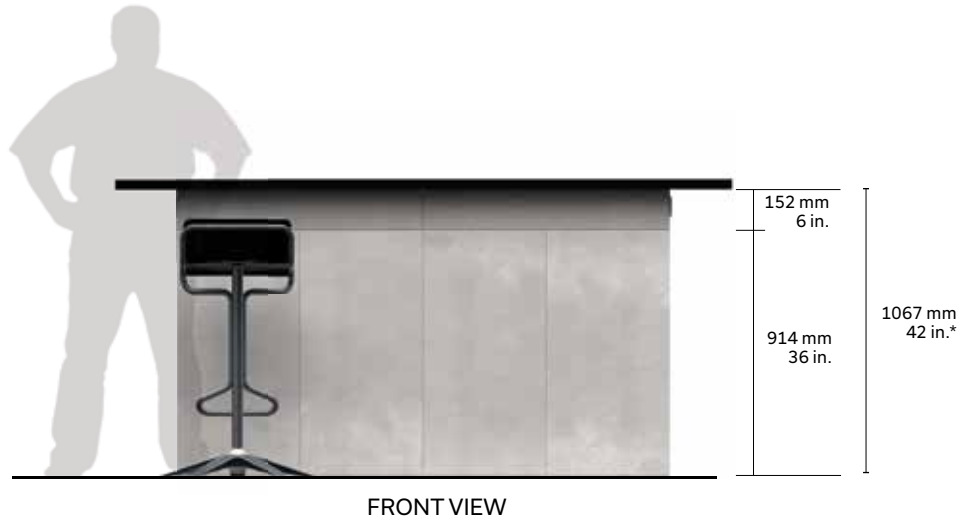

SEATING

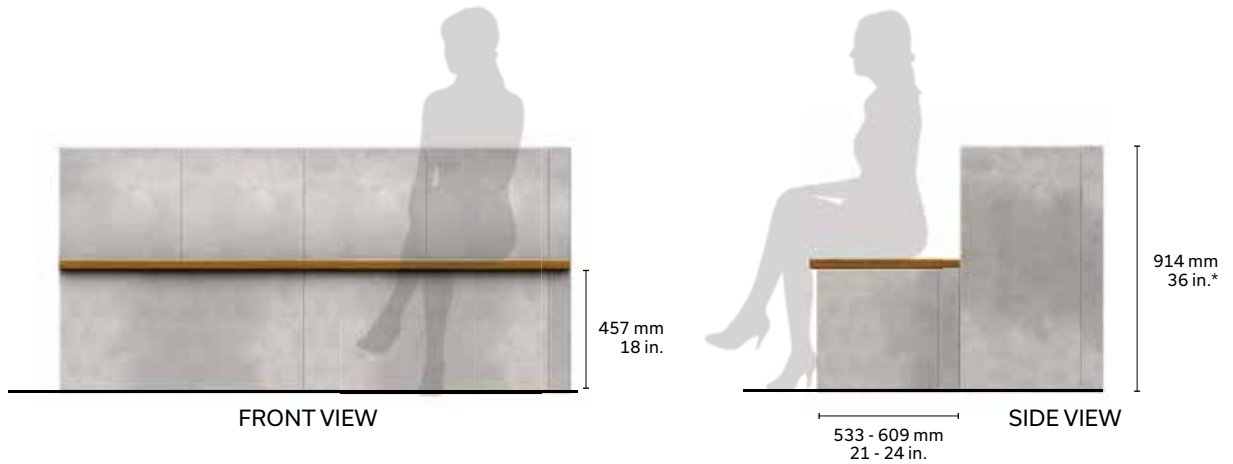

* Maximum height of 36 in. for planter box and 42 in. for outdoor living structure. Any higher structure must be designed by an engineer.

PANEL CONFIGURATIONS

Capping can be used to hide the dovetails.

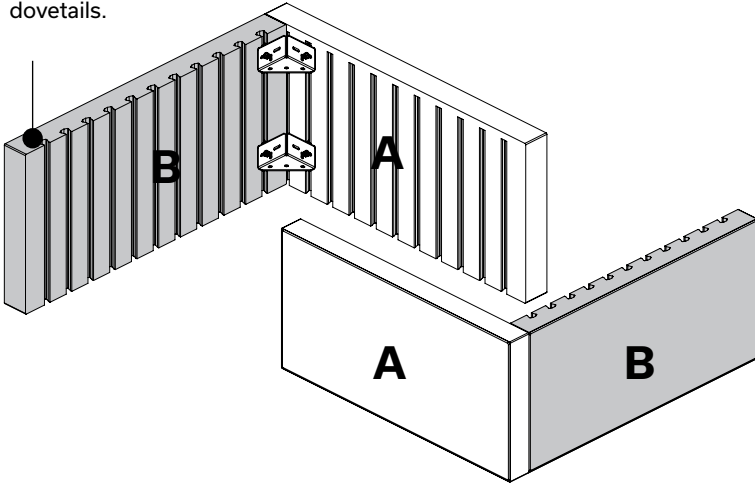

Capping optional

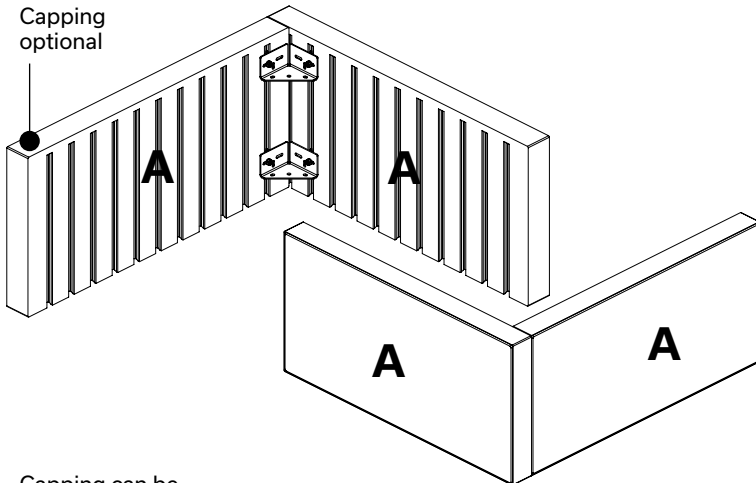

Capping can be used to hide the dovetails.

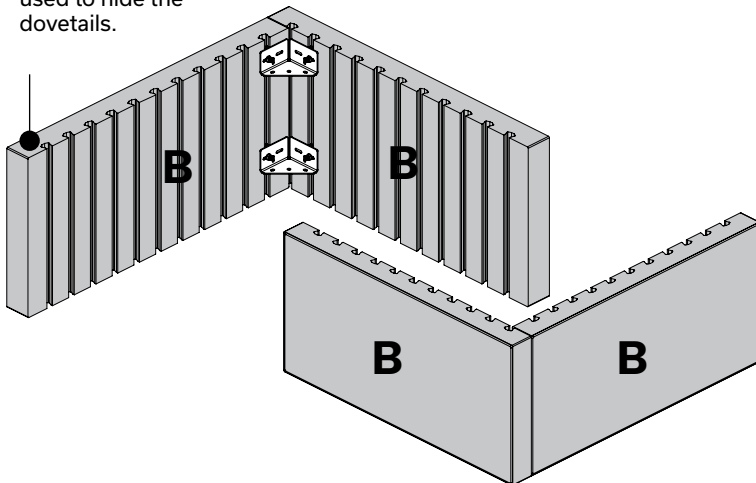

IDEAL:
This configuration uses equal number of panel A and panel B.

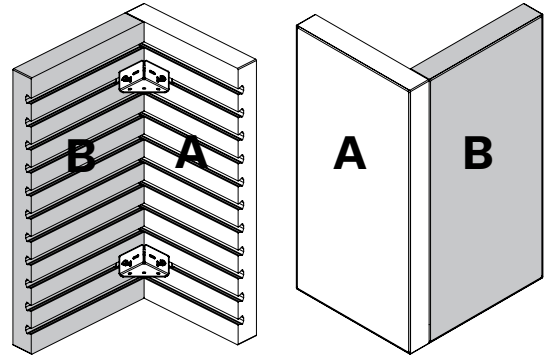

NOT OPTIMAL: This configuration uses panel A only.

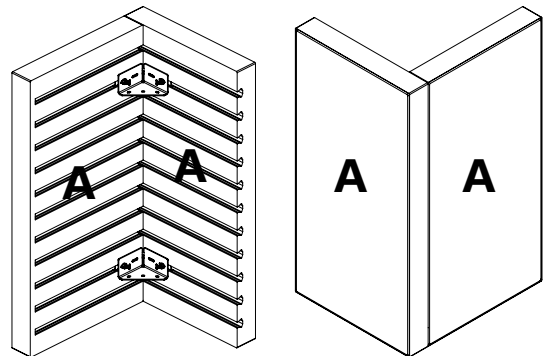

NOT OPTIMAL: This configuration uses panel B only and the dovetails are exposed. Use ideal configuration as shown above.

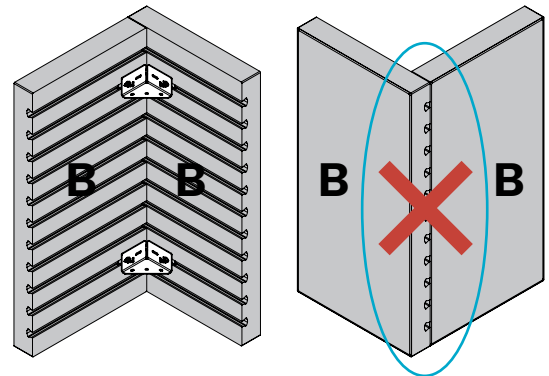

IMPORTANT: When planning configurations, consider the amount of panel A and panel B on a pallet. 18 x 36 in. panels are sold in pair/layer or in full pallet only. 6 x 36 in. panels are sold in layer or in full pallet only.

OUTER CORNER INSTALLATION

HORIZONTAL PANELS

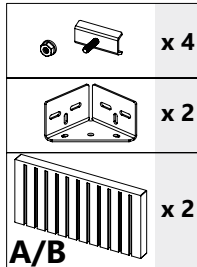
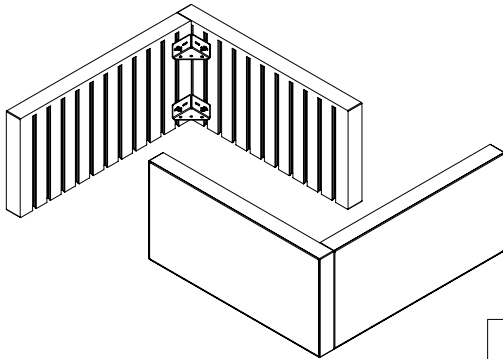

IMPORTANT: Always use a minimum of 2 outer corner brackets per corner assembly.

VERTICAL PANELS

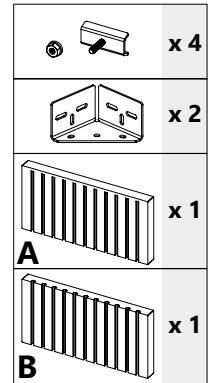
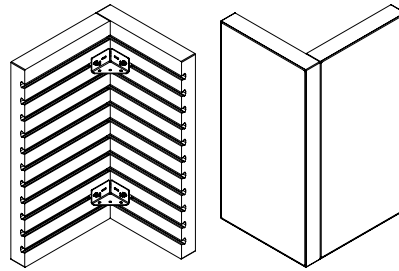

IMPORTANT: Always use a minimum of 2 outer corner brackets per corner assembly.

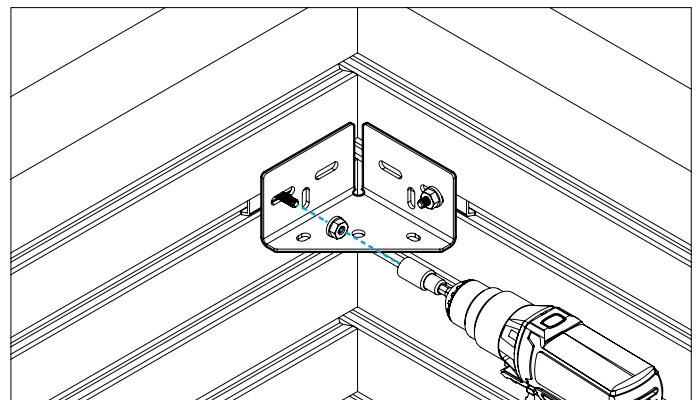
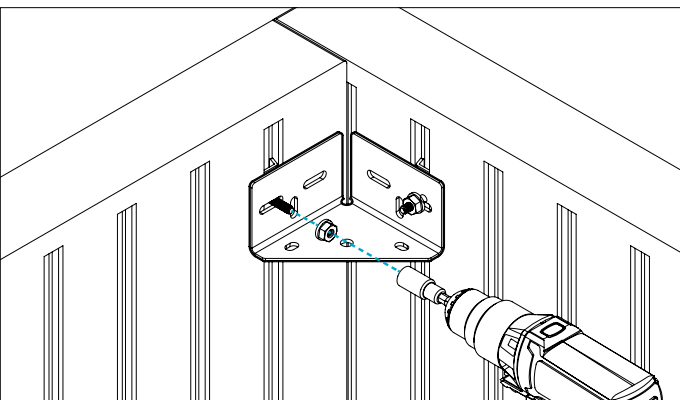
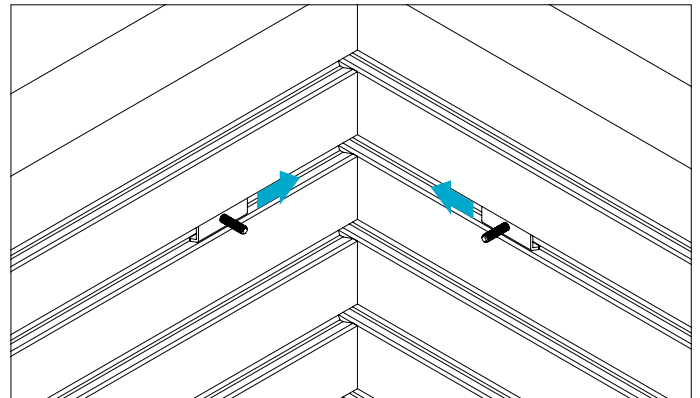
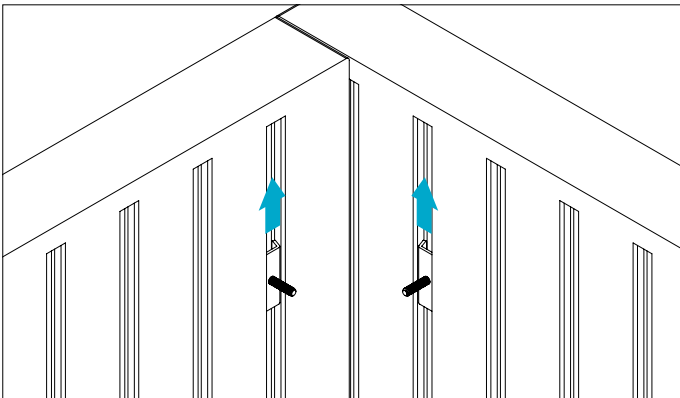

For more details, see **TIPS and TRICKS** at the end of this section.

INNER CORNER INSTALLATION

HORIZONTAL PANELS

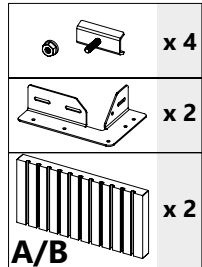
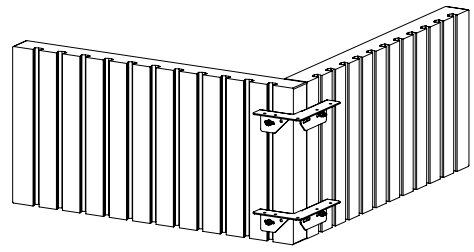

IMPORTANT: Always use a minimum of 2 inner corner brackets per corner assembly.

VERTICAL PANELS

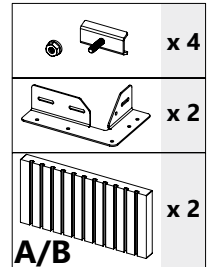
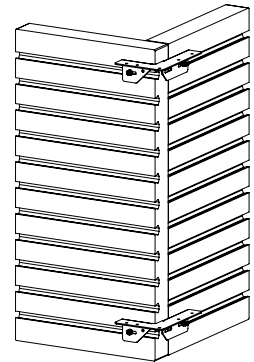

IMPORTANT: Always use a minimum of 2 inner corner brackets per corner assembly.

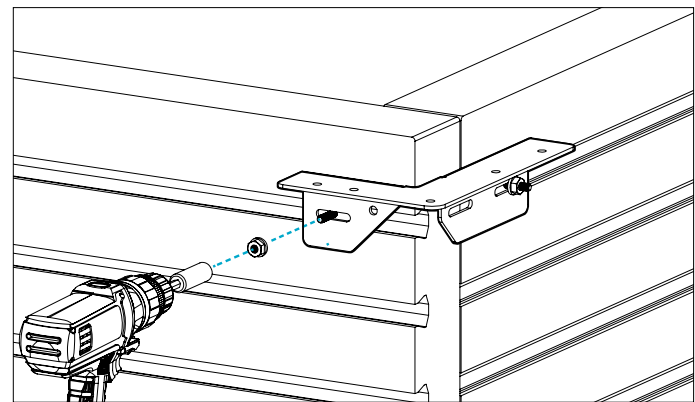
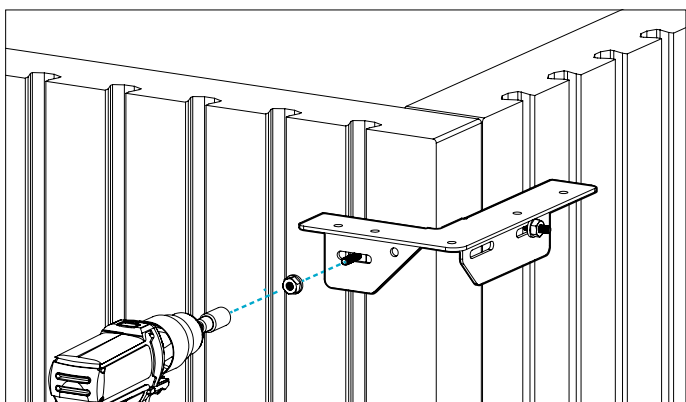
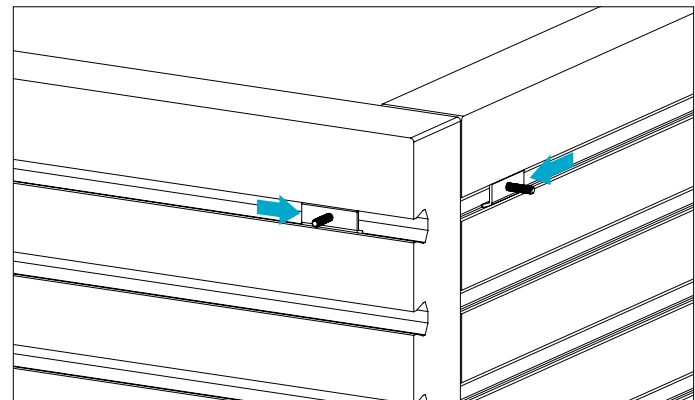
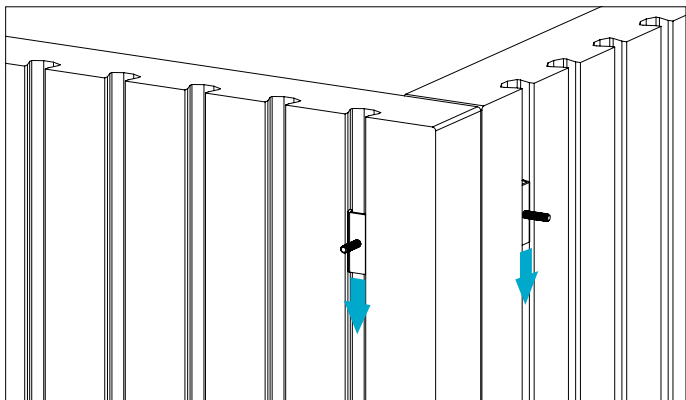

For more details, see **TIPS and TRICKS** at the end of this section.

JOINING PLATE INSTALLATION

HORIZONTAL PANELS

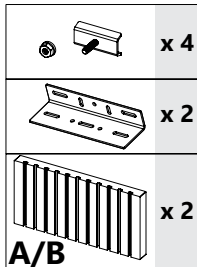
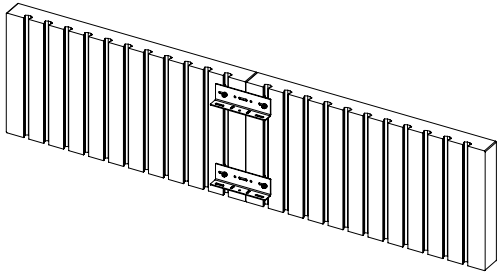

IMPORTANT: Always use a minimum of 2 joining plates when joining two parallel panels.

VERTICAL PANELS

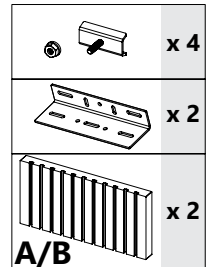
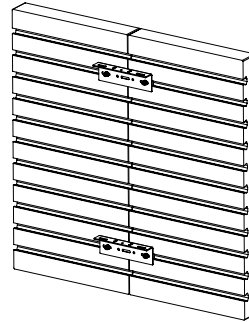

IMPORTANT: Always use a minimum of 2 joining plates when joining two parallel panels.

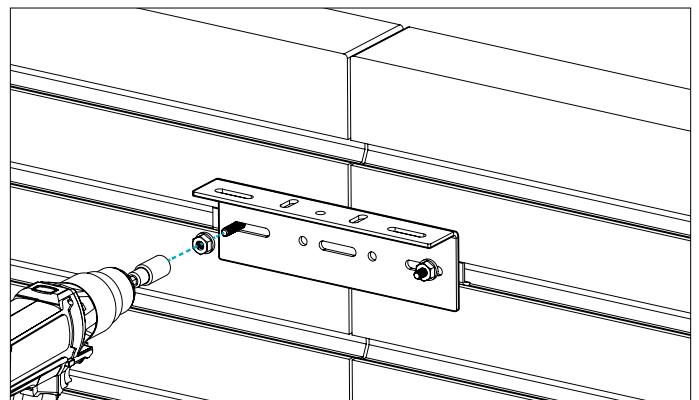
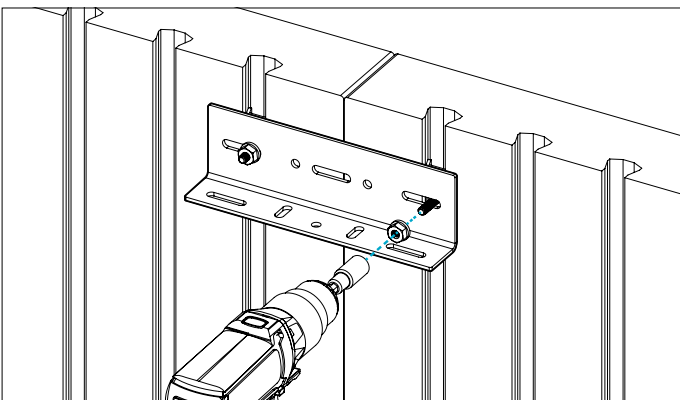
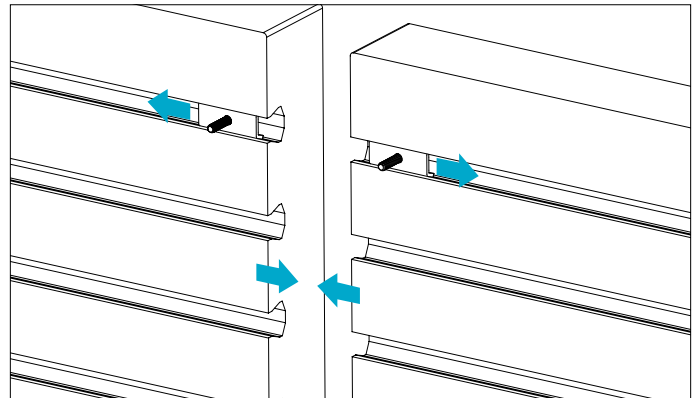
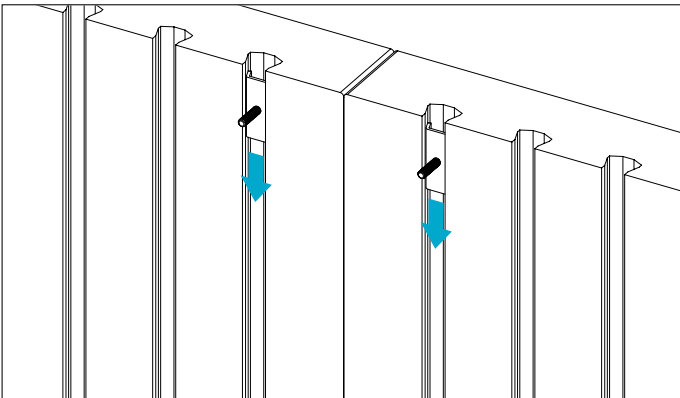

For more details, see **TIPS and TRICKS** at the end of this section.

STRETCHER BAR INSTALLATION - HORIZONTAL

HORIZONTAL PANELS

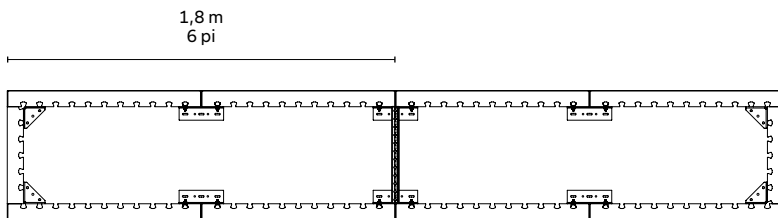
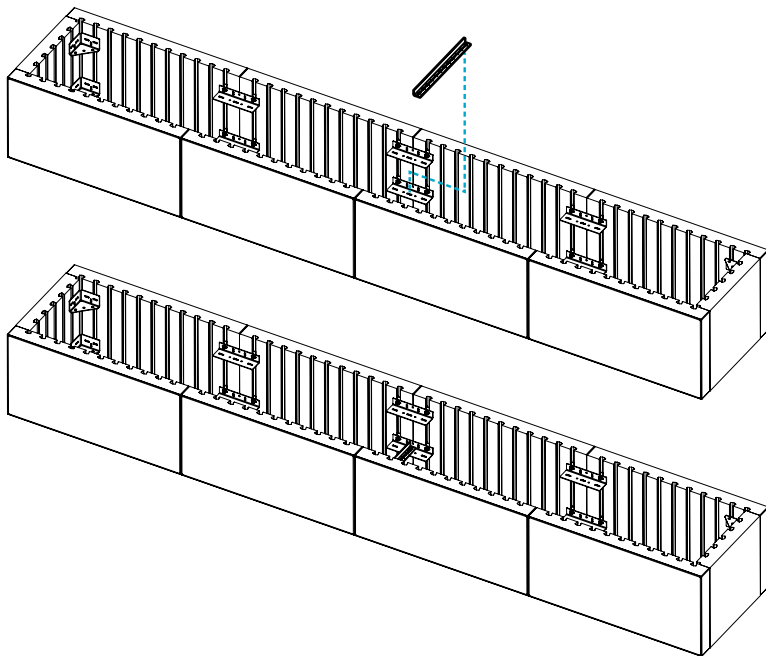
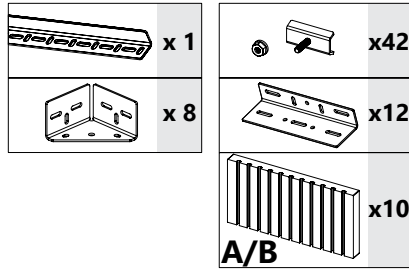

The stretcher bar keeps parallel 2 sets of panels facing each other. It is recommended to attach the stretcher bar to the joining plate every 6 ft. - 1.8m. Place it at 1/3 of the total height from the bottom of assembly.

The stretcher bar must be cut to fit distance between 2 sets of panels.

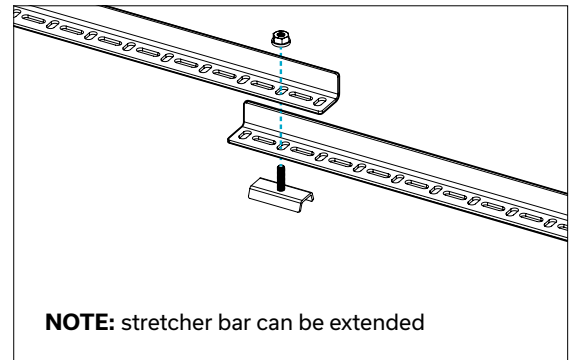
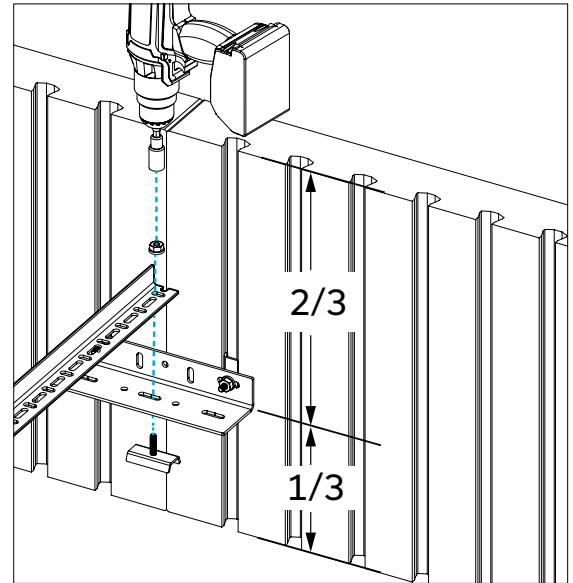

For more details, see **TIPS and TRICKS** at the end of this section.

STRETCHER BAR INSTALLATION - VERTICAL

VERTICAL PANELS

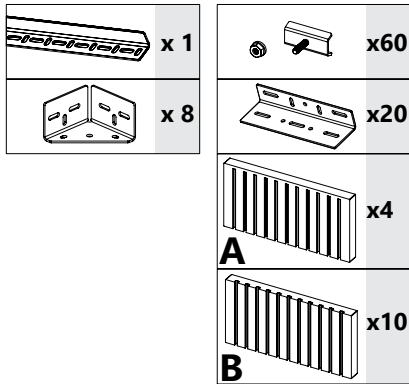

The stretcher bar keeps parallel 2 sets of panels facing each other. It is recommended to attach the stretcher bar to the joining plate every 3 ft. - 0.9 m. Place it at approximately 1/3 of the total height from the bottom of assembly.

The stretcher bar must be cut to fit distance between 2 sets of panels.

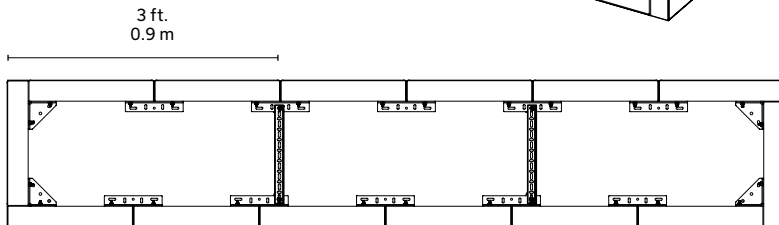
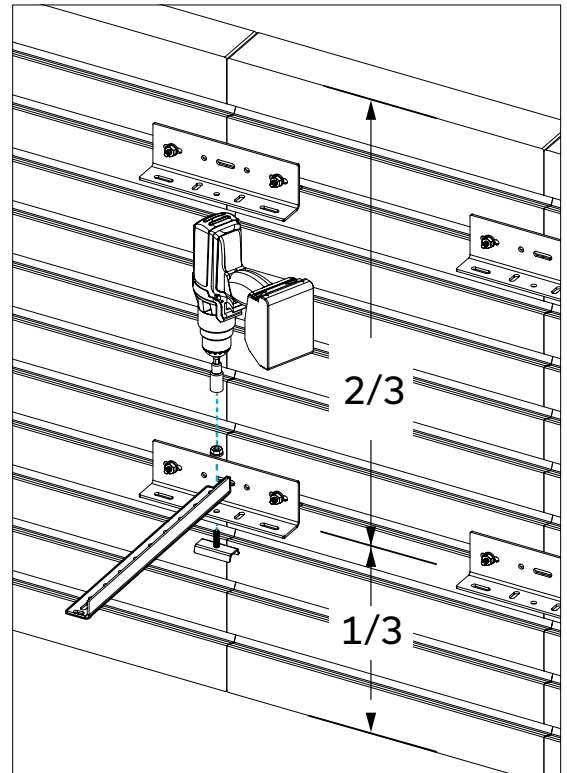
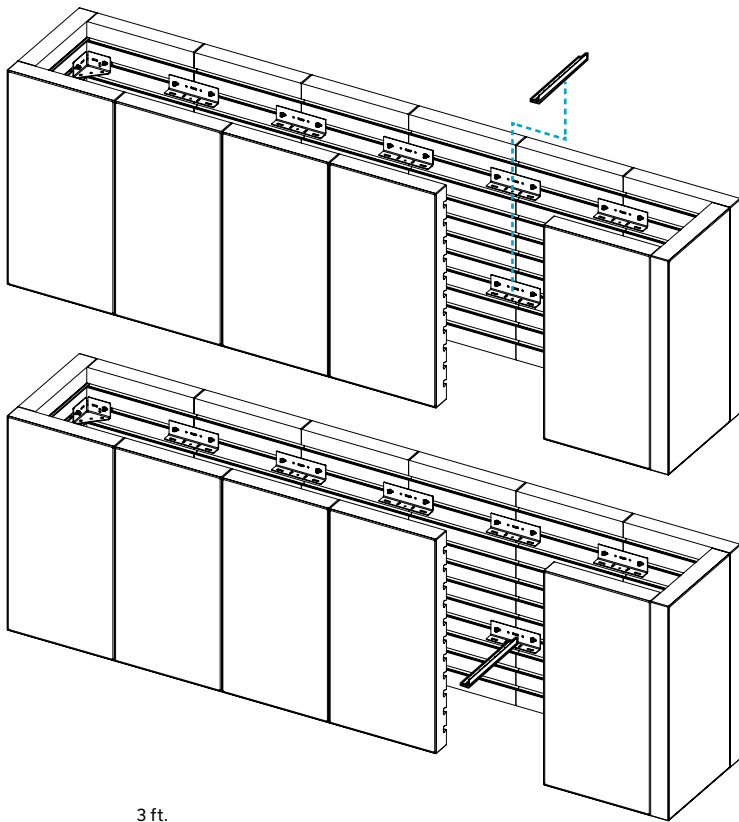

For more details, see **TIPS and TRICKS** at the end of this section.

6 X 36 PANEL - COPING INSTALLATION (MECHANICALLY FIXED)

HORIZONTAL PANELS

VERTICAL PANELS

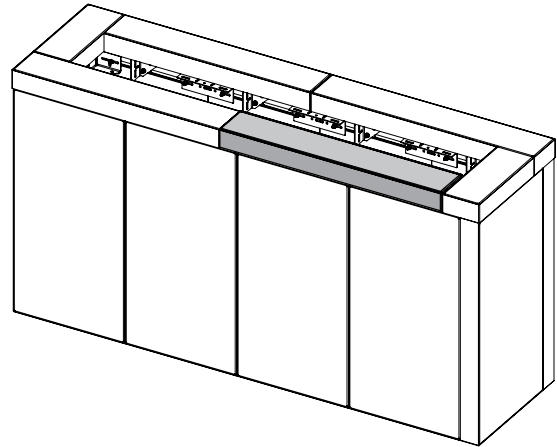
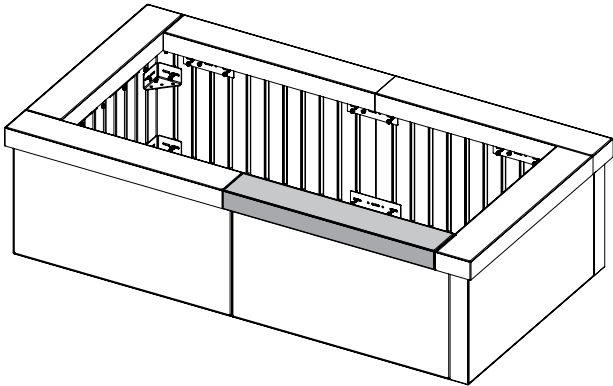

OVERHANG FROM
7/16 to 7/8 in.

OVERHANG FROM
1/8 to 7/8 in.

OVERHANG FROM
1/8 to 7/8 in.

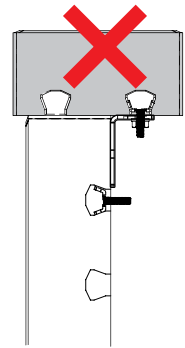
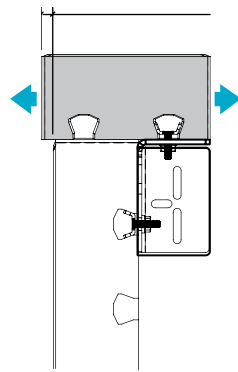
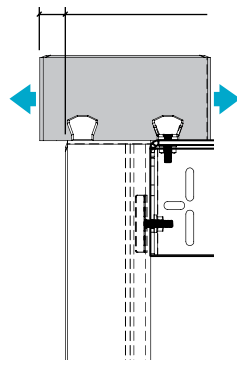
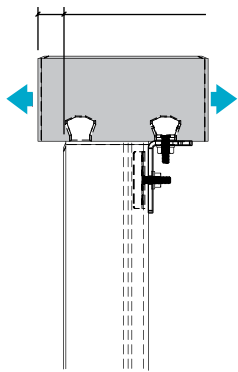

UNE AVANCÉE
(7/16 to 7/8 in.)

OPTION 1
(7/16 to 7/8 in.)

OPTION 1
(7/16 to 7/8 in.)

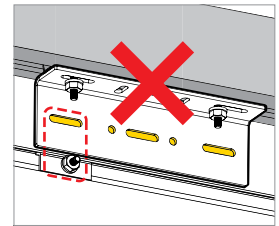
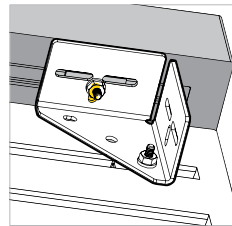
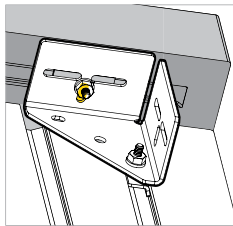
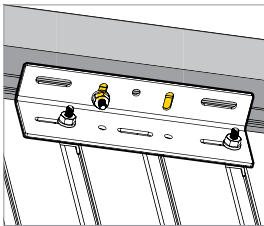

OPTION 2 (1/8 in.)

OPTION 2 (1/8 in.)

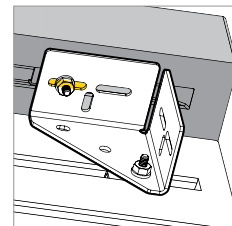
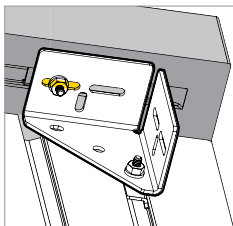

For more details, see **TIPS and TRICKS** at the end of this section.

6 X 36 PANEL - COPING INSTALLATION (FIXED WITH ADHESIVE)

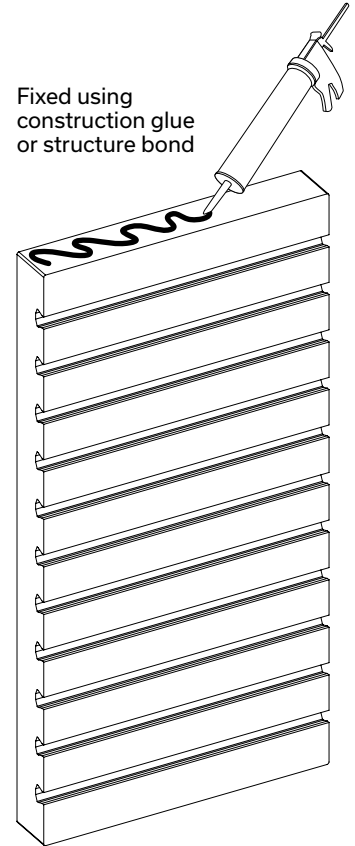
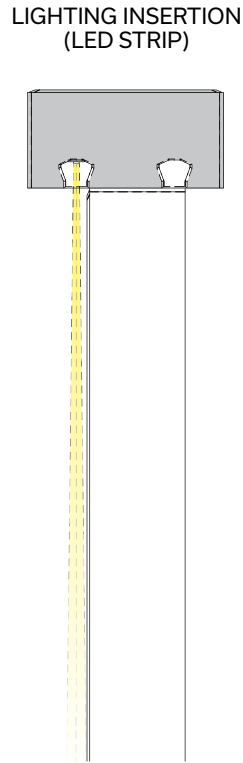
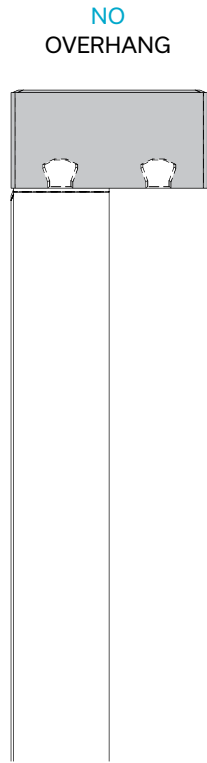
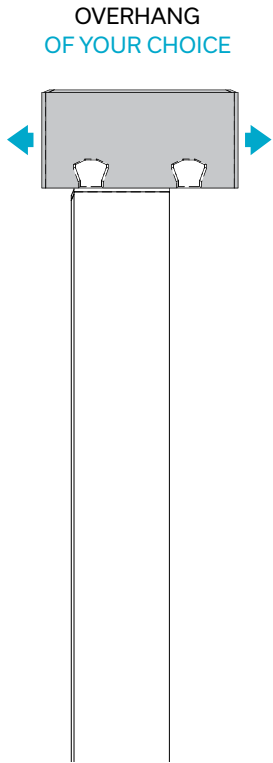

For more details, see **TIPS and TRICKS** at the end of this section.

6 X 36 PANEL – ACCENT INSTALLATION

HORIZONTAL PANELS

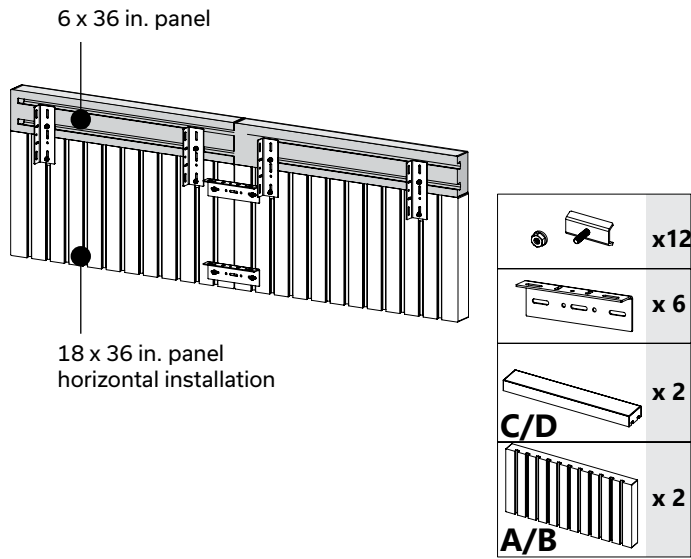

VERTICAL PANELS

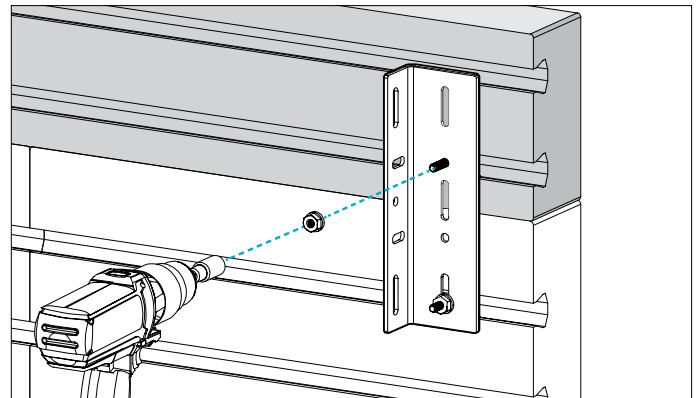
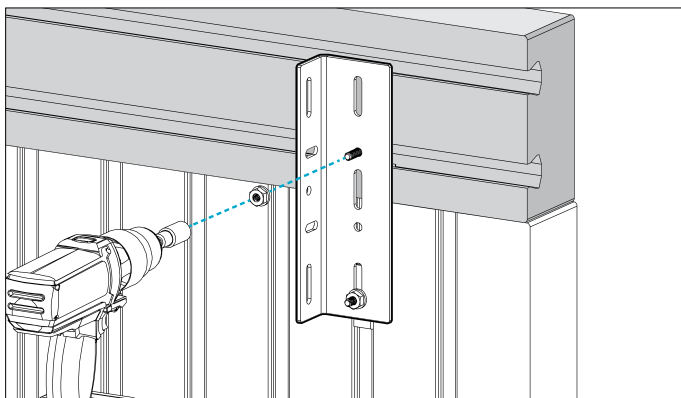
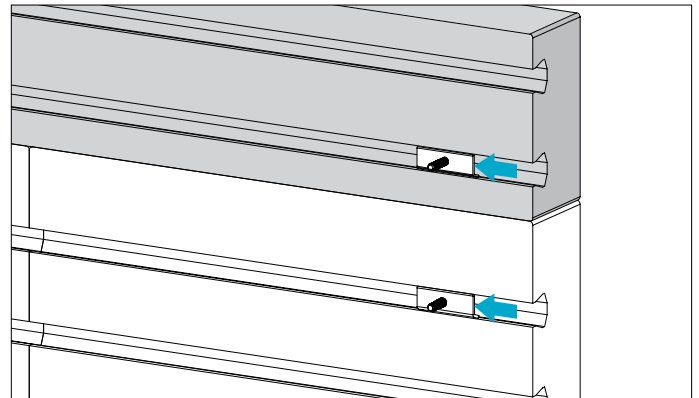
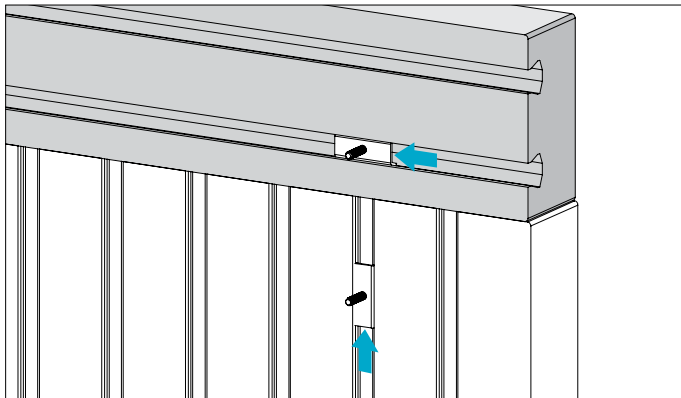
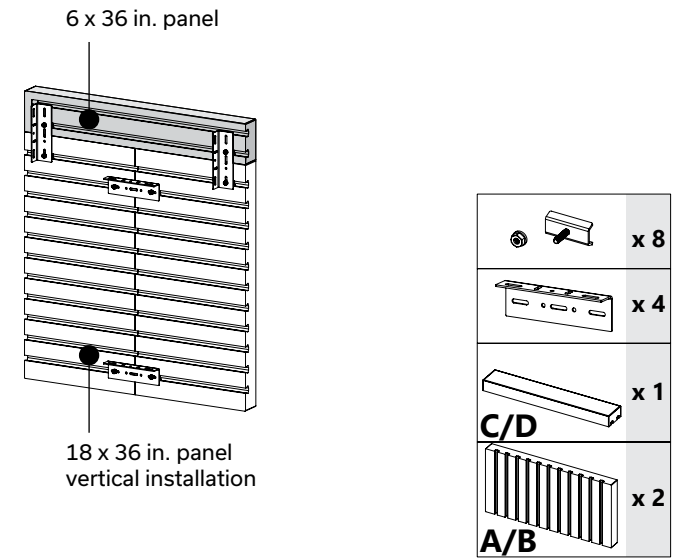

For more details, see **TIPS and TRICKS** at the end of this section.

INTEGRATING WOOD

BENCH

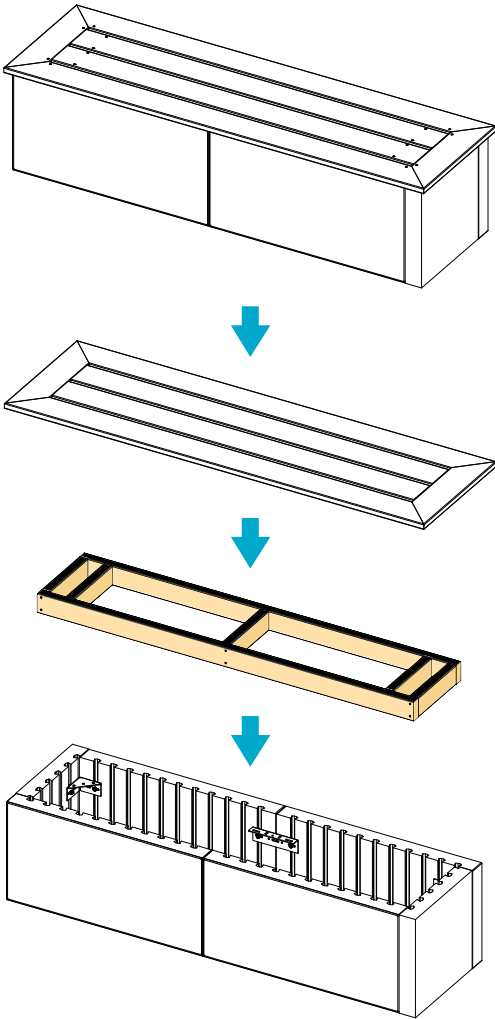

	x24
	x 8
	x 4
	x 6
A/B	
	TREATED WOOD SCREW #8 OR 10

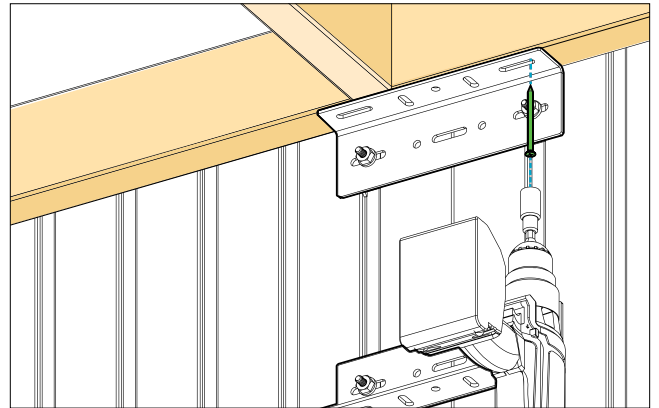
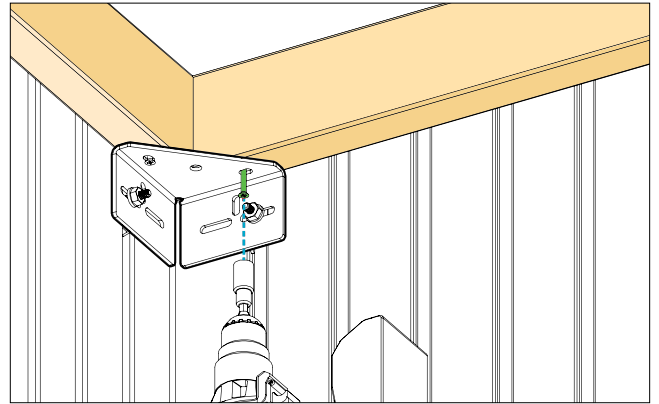

Install the hardware according to wood size

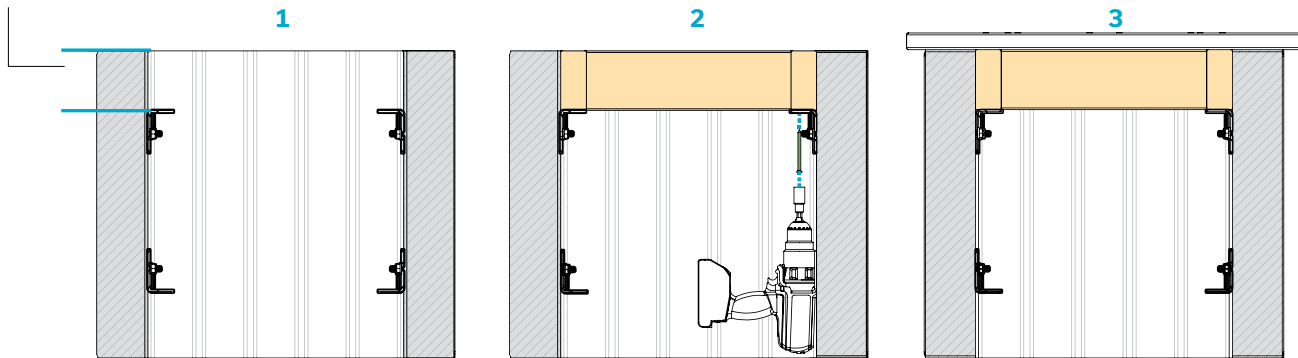

SECTION VIEW

For more details, see **TIPS and TRICKS** at the end of this section.

INTEGRATING 4 X 4 IN. WOOD POSTS

HORIZONTAL PANELS

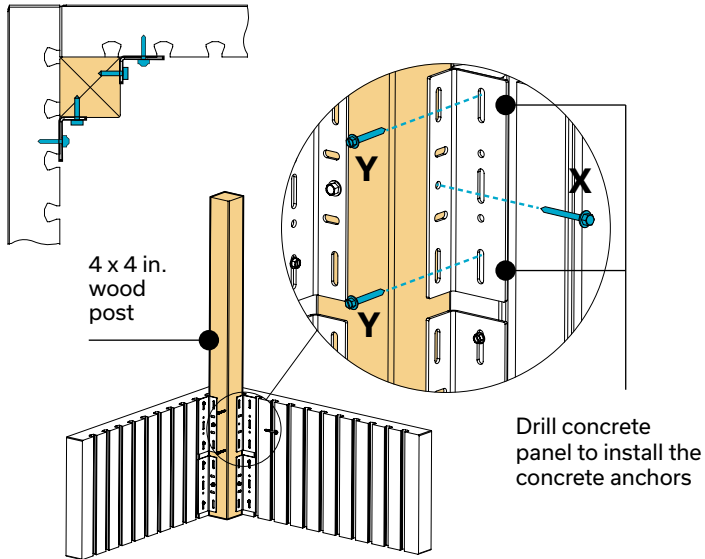

VERTICAL PANELS

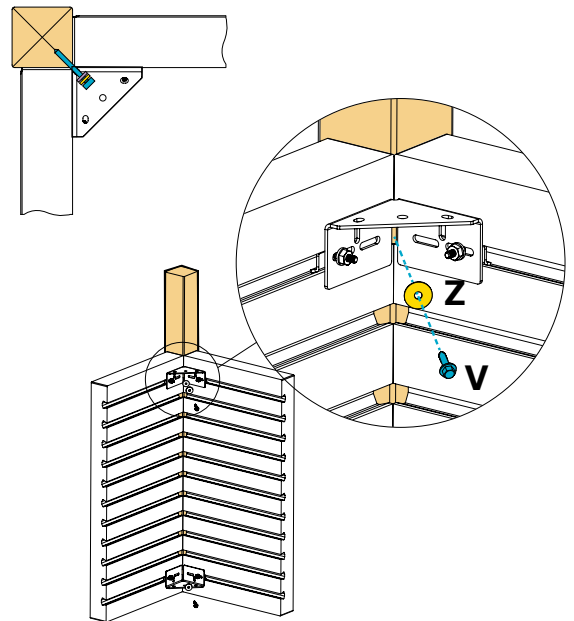
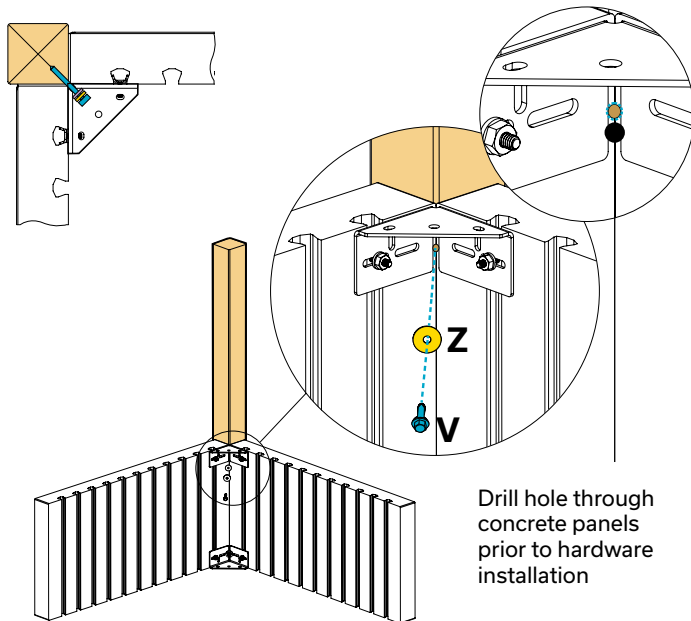
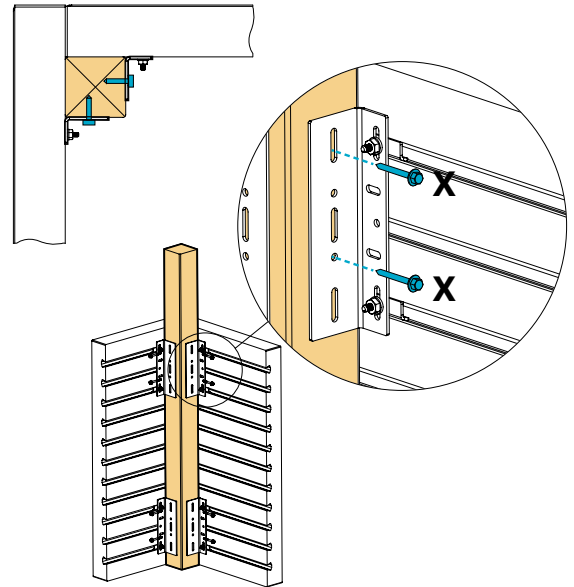

IMPORTANT: Other types of hardware (not included) may be required to make these assemblies (wood screws, concrete anchors, etc.). PERMACON is not responsible for any issue regarding other materials, accessories, other types of hardware, etc. We recommend consulting an expert/engineer to determine the design limitations of the screen panels based on wind loads.

- X** = Stainless steel wood screw flat head #10 x 2 1/2 in.
- Y** = Treated concrete anchor (Tapcon®) 1/4 x 1 3/4 in. or 3/16 x 1 3/4 in.
- V** = Stainless steel lag screws 1/4 x 2 1/2 in. or 5/16 x 2 1/2 in.
- Z** = Stainless steel oversized washer 5/16 in.

For more details, see **TIPS and TRICKS** at the end of this section.

INTEGRATING 4 X 4 IN. WOOD POSTS - CONT'D

HORIZONTAL PANELS

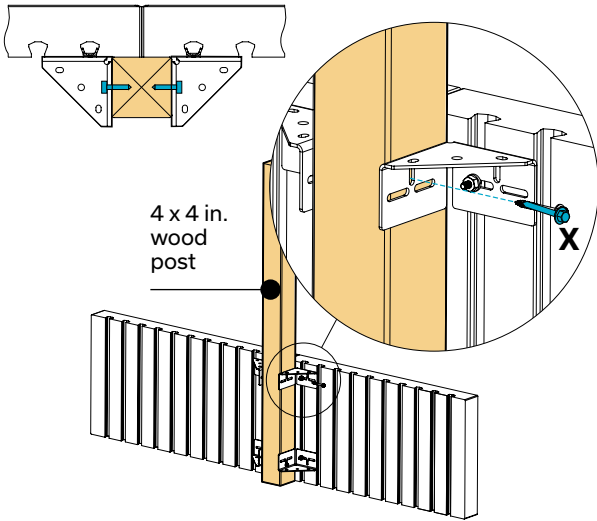

VERTICAL PANELS

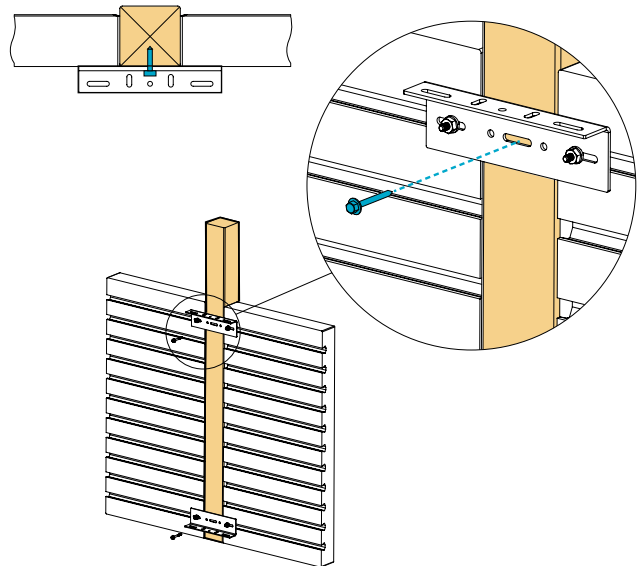
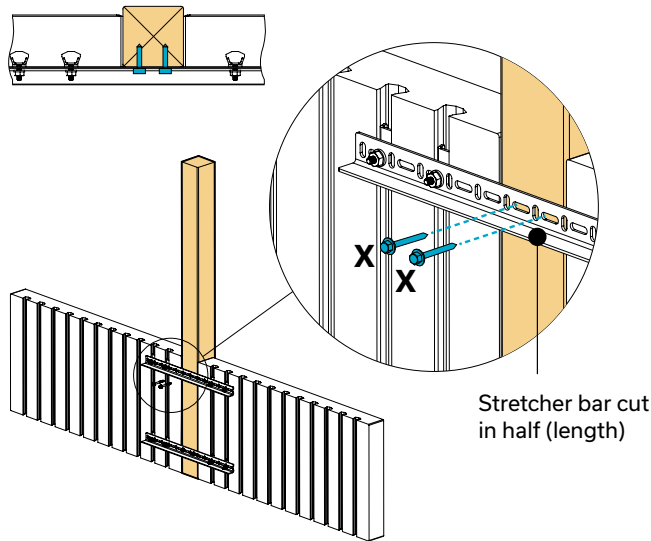
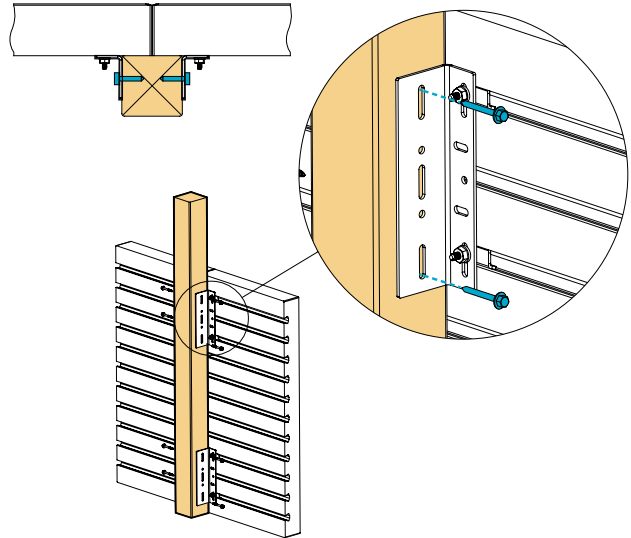

IMPORTANT: Other types of hardware (not included) may be required to make these assemblies (wood screws, concrete anchors, etc.). PERMACON is not responsible for any issue regarding other materials, accessories, other types of hardware, etc. We recommend consulting an expert/engineer to determine the design limitations of the screen panels based on wind loads.

- X** = Stainless steel wood screw flat head #10 x 2 1/2 in.
- Y** = Treated concrete anchor (Tapcon®) 1/4 x 1 3/4 in. or 3/16 x 1 3/4 in.
- V** = Stainless steel lag screws 1/4 x 2 1/2 in. or 5/16 x 2 1/2 in.
- Z** = Stainless steel oversized washer 5/16 in.

For more details, see **TIPS and TRICKS** at the end of this section.

INTEGRATING 4 X 4 IN. WOOD POSTS - CONT'D

HORIZONTAL PANELS

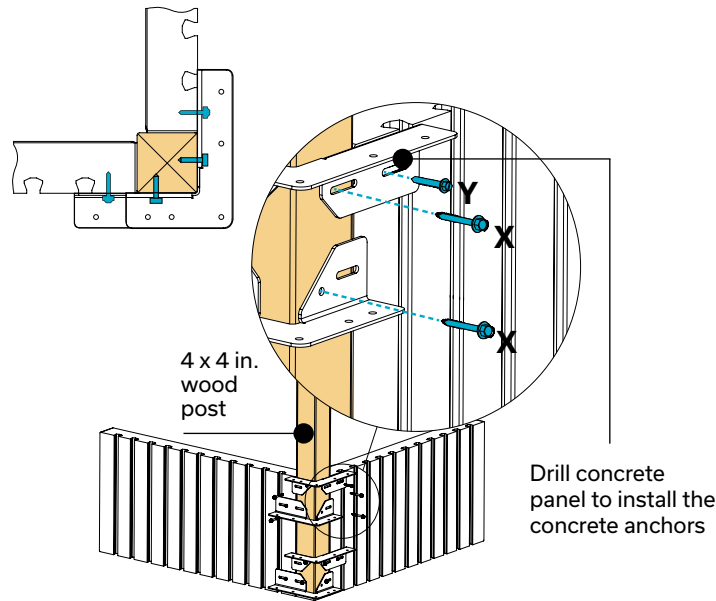

VERTICAL PANELS

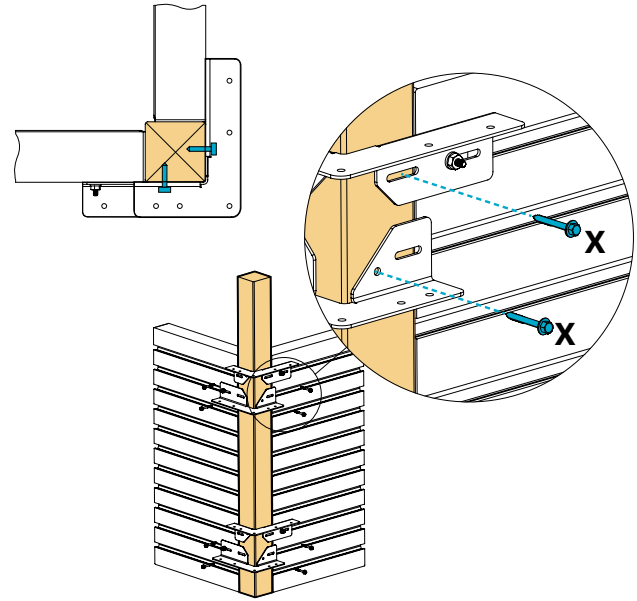

IMPORTANT: Other types of hardware (not included) may be required to make these assemblies (wood screws, concrete anchors, etc.). PERMACON is not responsible for any issue regarding other materials, accessories, other types of hardware, etc. *We recommend consulting an expert/engineer to determine the design limitations of the screen panels based on wind loads.*

- X** = Stainless steel wood screw flat head #10 x 2 1/2 in.
- Y** = Treated concrete anchor (Tapcon®) 1/4 x 1 3/4 in. or 3/16 x 1 3/4 in.
- V** = Stainless steel lag screws 1/4 x 2 1/2 in. or 5/16 x 2 1/2 in.
- Z** = Stainless steel oversized washer 5/16 in.

For more details, see **TIPS and TRICKS** at the end of this section.

BASE PREPARATION

ON EXISTING PATIO

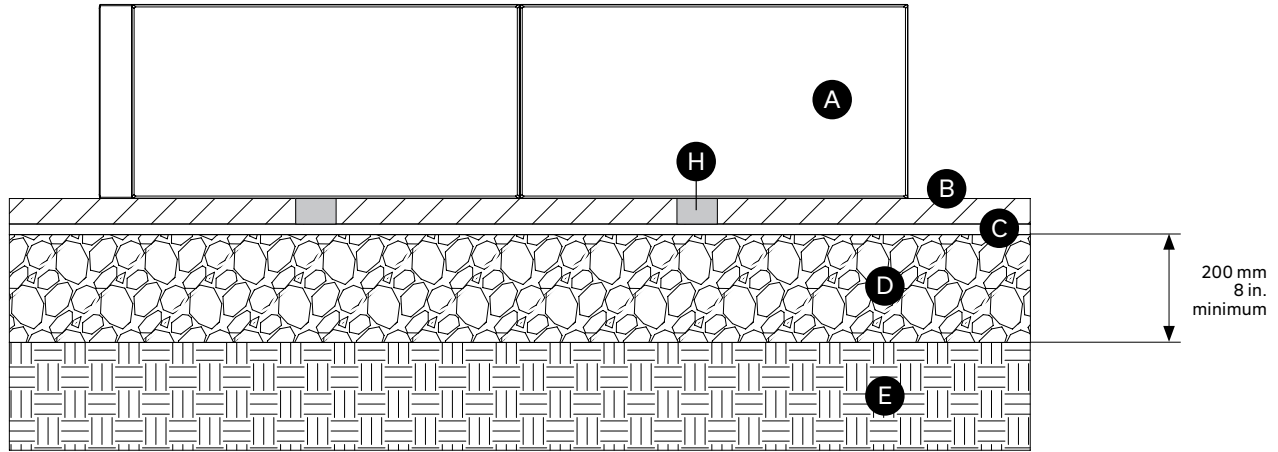

ON POURED CONCRETE FOUNDATION

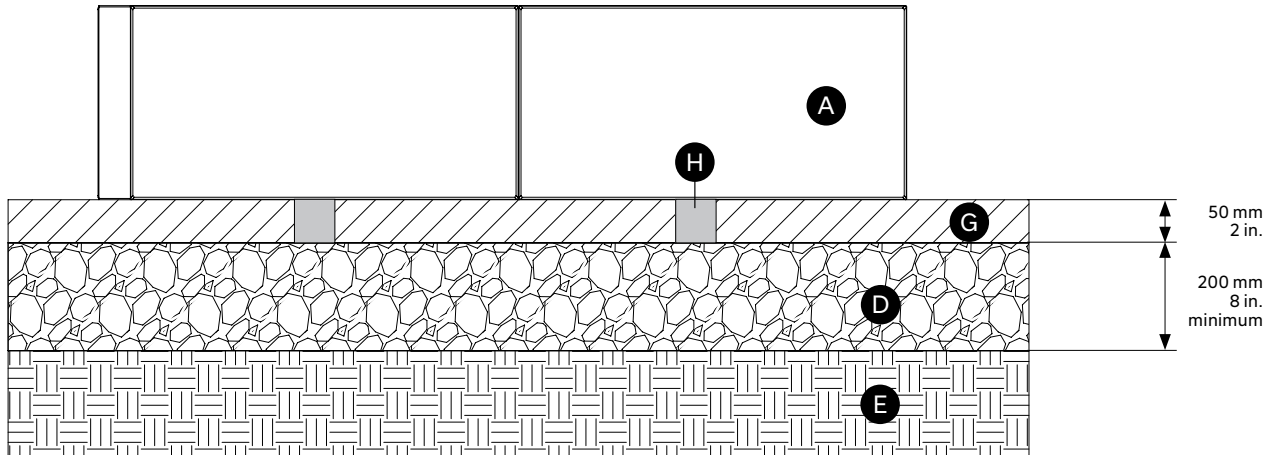

- Ⓐ Artex panel
- Ⓑ Slab or paver
- Ⓒ bedding sand 1 in. - 25 mm
- Ⓓ Compacted aggregates 8 in. - 200 mm minimum
- Ⓔ Soil
- Ⓕ Starter unit / slab or paver
- Ⓖ Reinforced poured concrete foundation 2 in. - 50 mm min.
- Ⓗ Opening for drainage

IMPORTANT: Provide adequate drainage and adjust according to soil type. Maximum height of 36 in. for planter box and 42 in. for outdoor living structure. Any higher structure must be designed by an engineer. Dimensions and information above are general recommendations only. Contact experts/engineers to validate the base preparation, the drainage, the plants & roots growth/management. The use of plastic shims can facilitate the installation of Artex panels in order to adapt to the slope of the site.

BASE PREPARATION - CONT'D

ON COMPACTED FOUNDATION USING STARTER UNIT

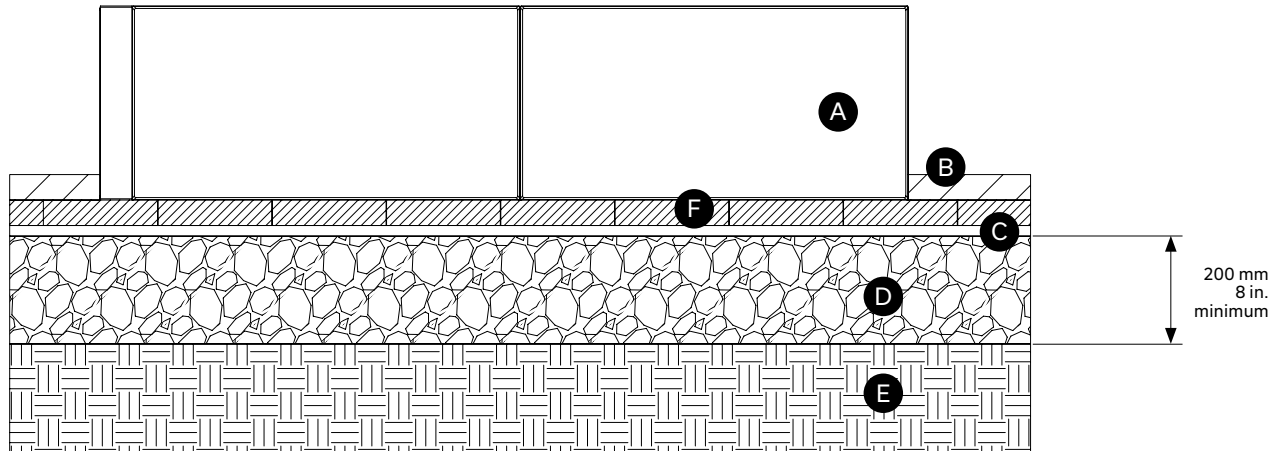

ON COMPACTED FOUNDATION

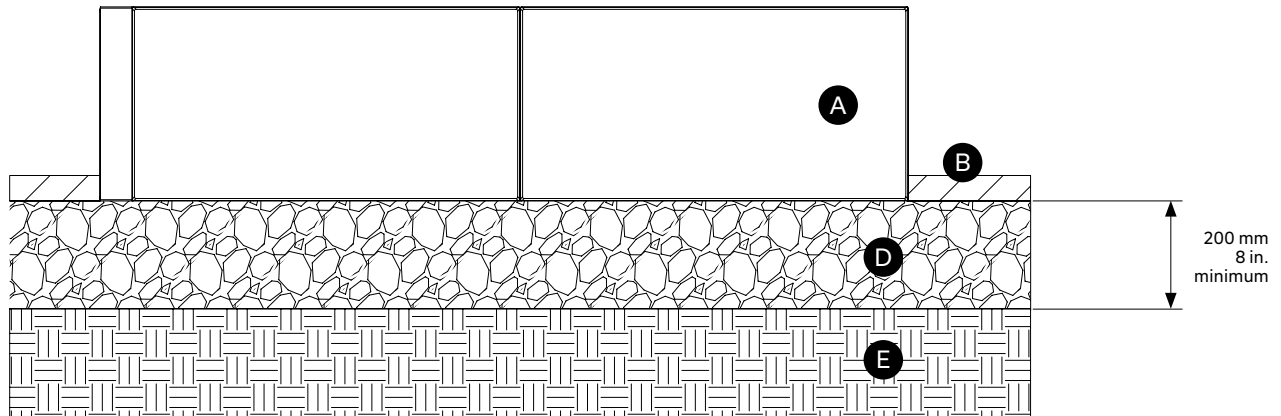

- Ⓐ Artex panel
- Ⓑ Slab or paver
- Ⓒ bedding sand 1 in. - 25 mm
- Ⓓ Compacted aggregates 8 in. - 200 mm minimum
- Ⓔ Soil
- Ⓕ Starter unit / slab or paver
- Ⓖ Reinforced poured concrete foundation 2 in. - 50 mm min.
- Ⓗ Opening for drainage

IMPORTANT: Provide adequate drainage and adjust according to soil type. Maximum height of 36 in. for planter box and 42 in. for outdoor living structure. Any higher structure must be designed by an engineer. Dimensions and information above are general recommendations only. Contact experts/engineers to validate the base preparation, the drainage, the plants & roots growth/management. The use of plastic shims can facilitate the installation of Artex panels in order to adapt to the slope of the site.

PLANTER BOX DETAIL

ON COMPACTED FOUNDATION

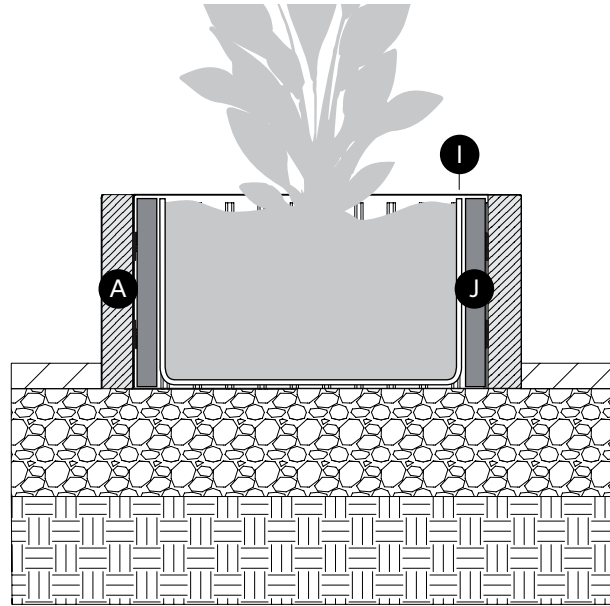
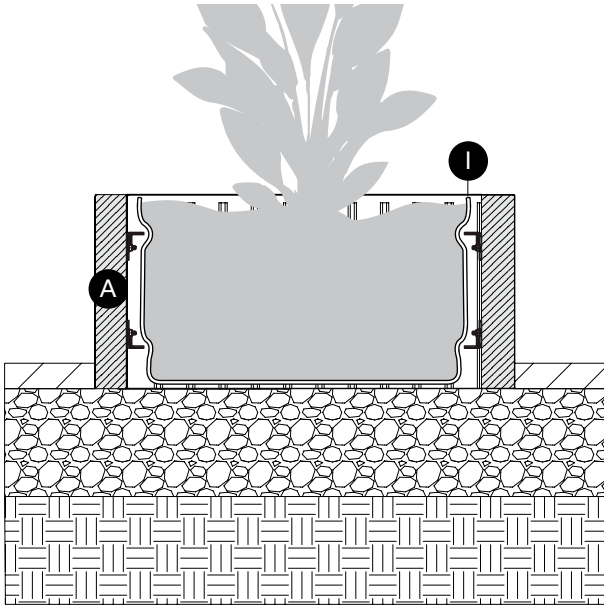

RECOMMENDED:
Place insulated panels to protect plants from cold conditions.

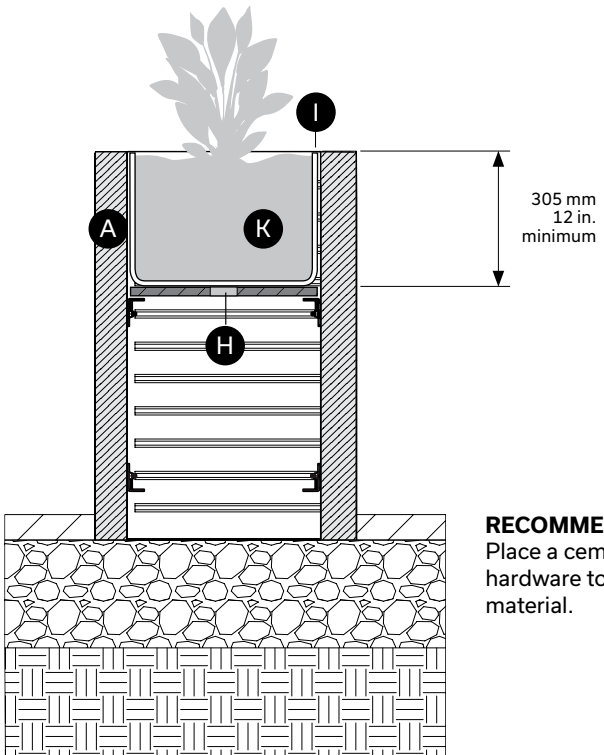

RECOMMENDED:
Place a cement board on top of the Artex hardware to reduce the amount of infill material.

IMPORTANT: Provide adequate drainage and adjust according to soil type. Maximum height of 36 in. for planter box and 42 in. for outdoor living structure. Any higher structure must be designed by an engineer. Dimensions and information above are general recommendations only. Contact experts/engineers to validate the base preparation, the drainage, the plants & roots growth/management. The use of plastic shims can facilitate the installation of Artex panels in order to adapt to the slope of the site.

- A** Artex panel
- H** Opening for drainage
- I** Geotextile membrane
- J** Insulated panel
- K** Structural water resistant panel

ROOFTOP APPLICATIONS

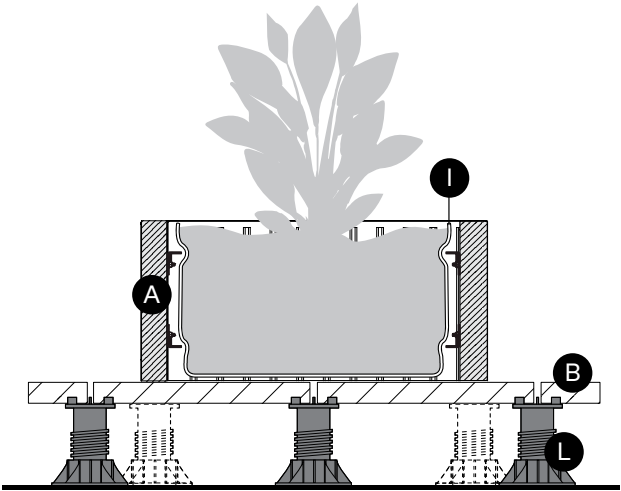

Planter box with horizontal panels sitting on slabs/tiles - section view

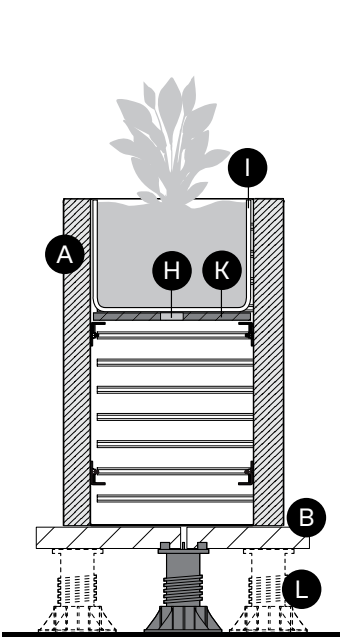
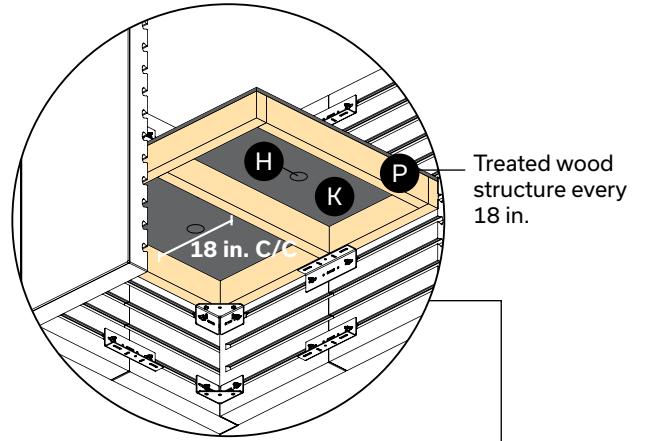

Planter box with vertical panels sitting on slabs/tiles - section view

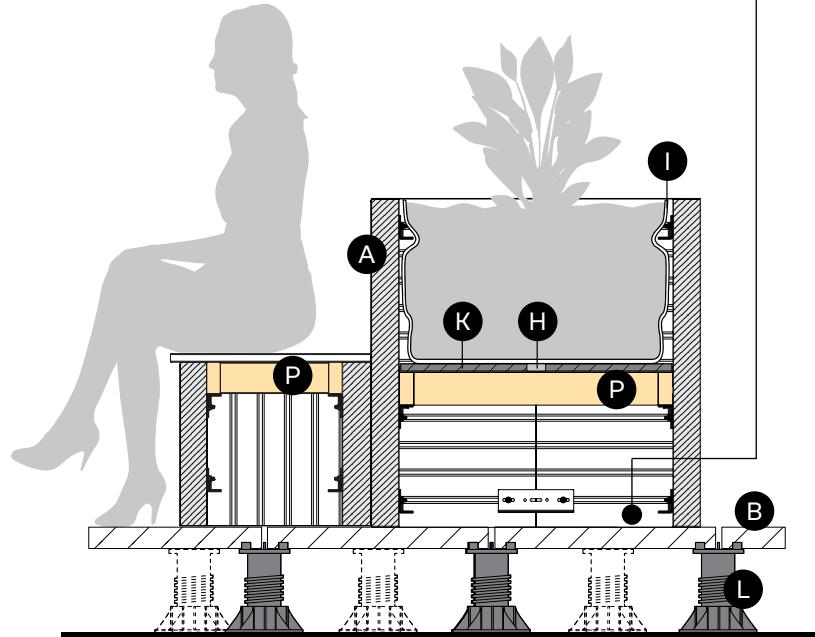

Planter box and bench sitting on slabs/tiles - section view

- Ⓐ Artx panel
- Ⓑ Slab or paver
- Ⓗ Opening for drainage
- Ⓘ Geotextile membrane
- Ⓚ Structural water resistant panel
- Ⓛ Pedestal
- Ⓟ Treated wood structure

IMPORTANT: Contact experts/engineers for proper staging on existing rooftop surfaces.

ROOFTOP APPLICATIONS - CONT'D

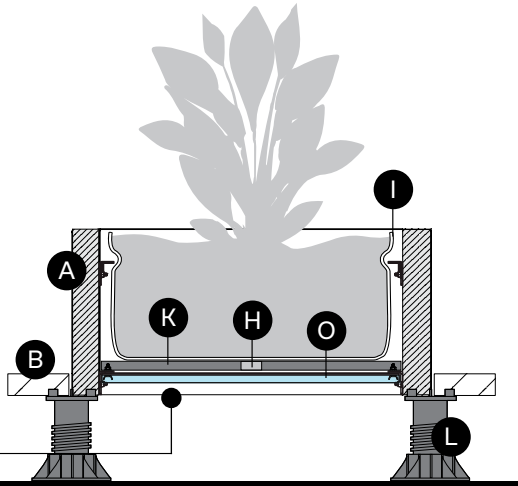

Planter box sitting on pedestals - section view

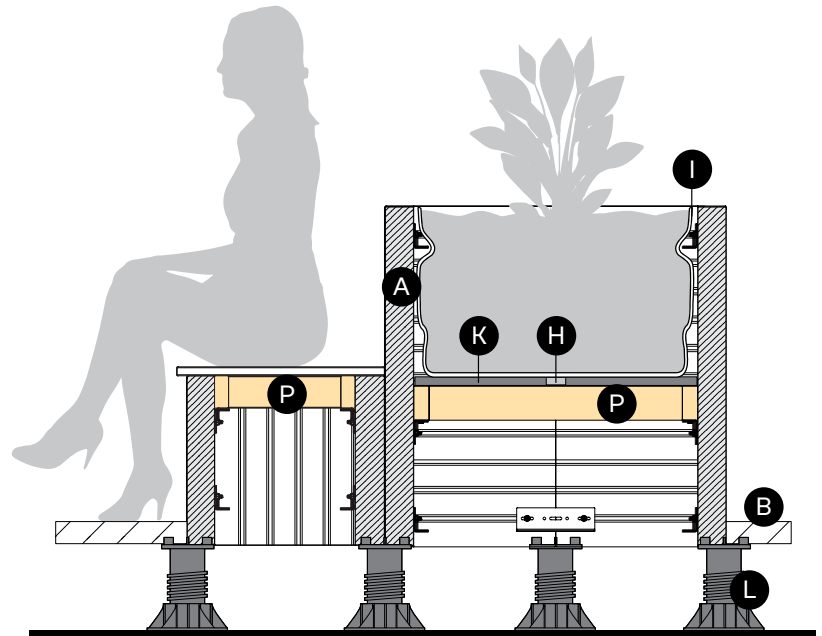

Bench and planter box sitting on pedestals - section view

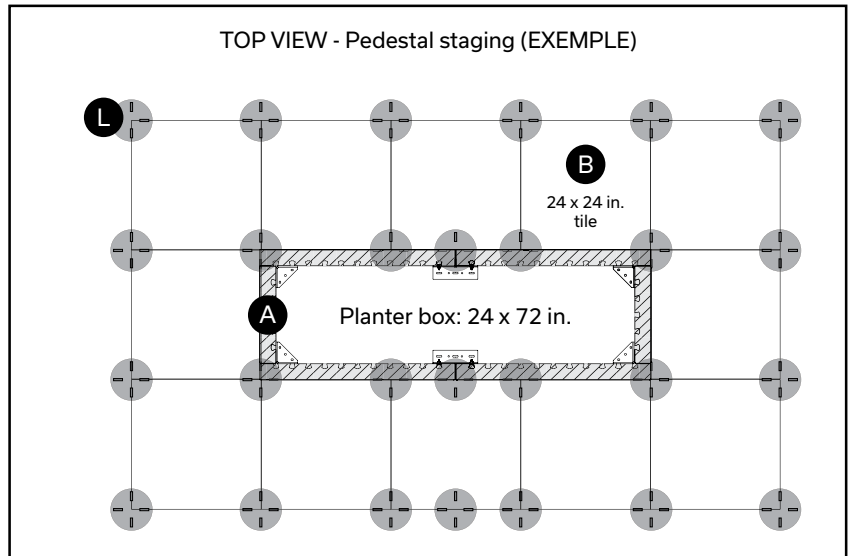
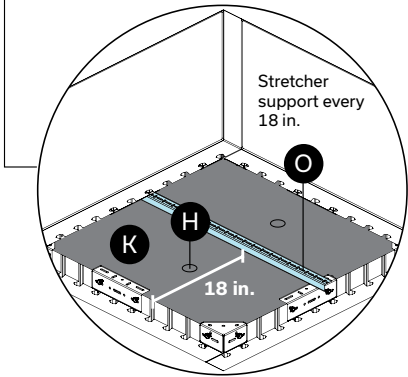

- Ⓐ Artex panel
- Ⓑ Slab or paver
- Ⓗ Opening for drainage
- Ⓘ Geotextile membrane
- Ⓚ Structural water resistant panel
- Ⓛ Pedestal
- Ⓞ Stretcher bar
- Ⓟ Treated wood structure

IMPORTANT: Contact experts/engineers for proper staging on existing rooftop surfaces.

HANDLING

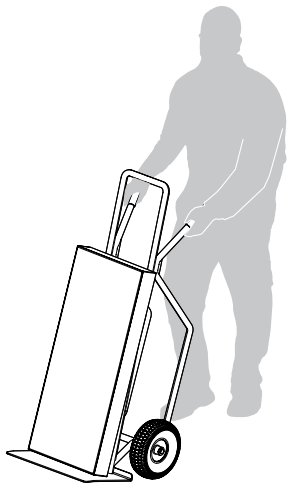
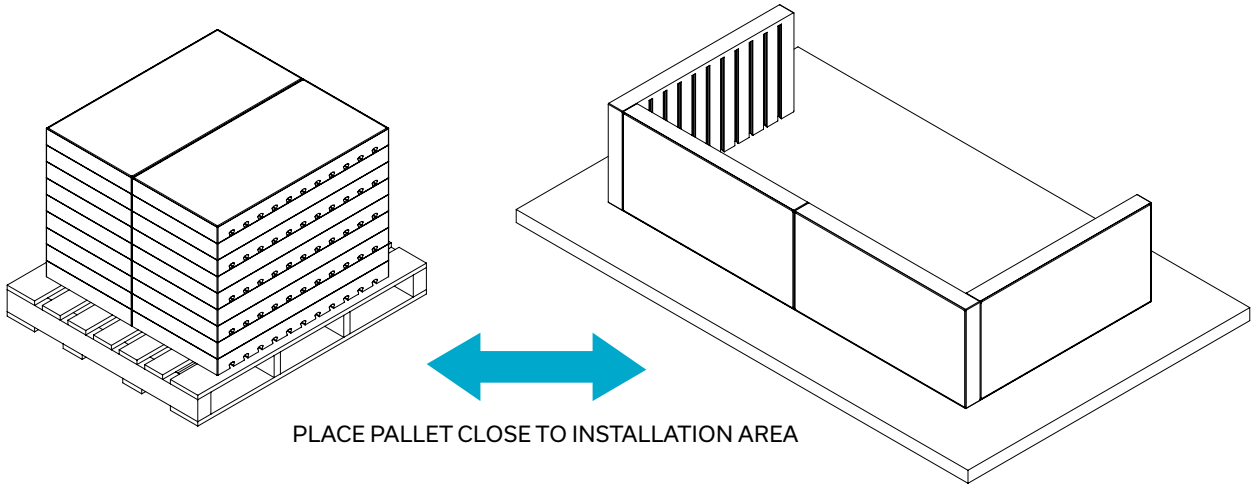

Use hand trolley if necessary

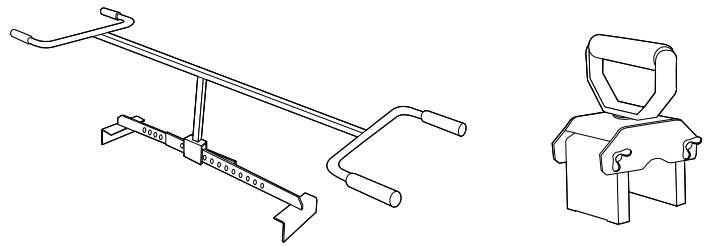

Recommended handling tools

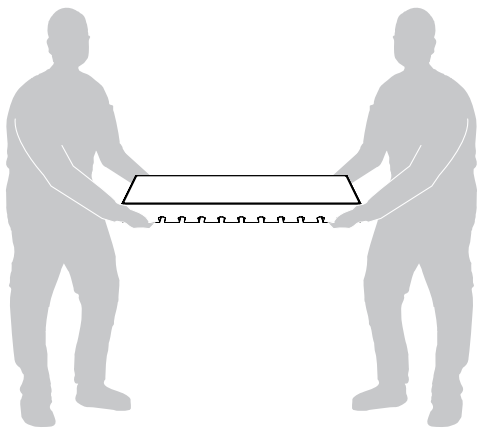

Lift with two people

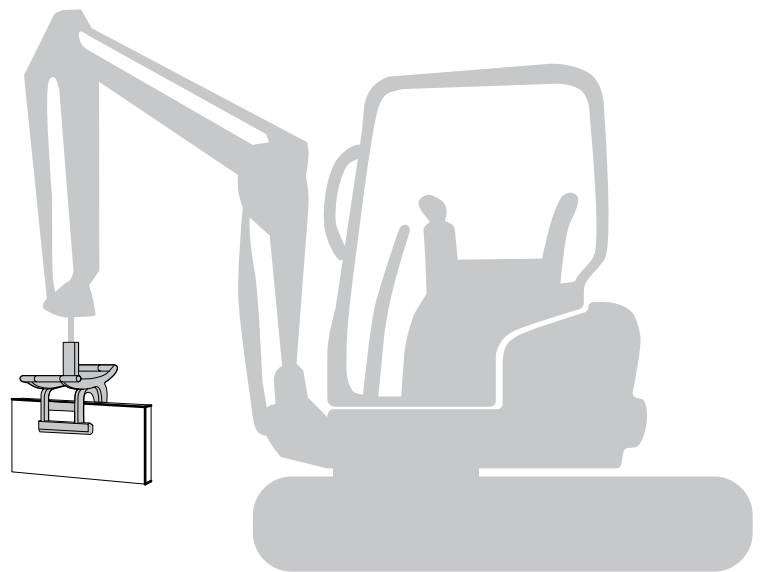

Use a mechanical lifting device

TIPS AND TRICKS

1 GENERAL

Ensure that all the panels are in place, levelled & aligned before fully tightening the hardware in the corners at the end of the installation.

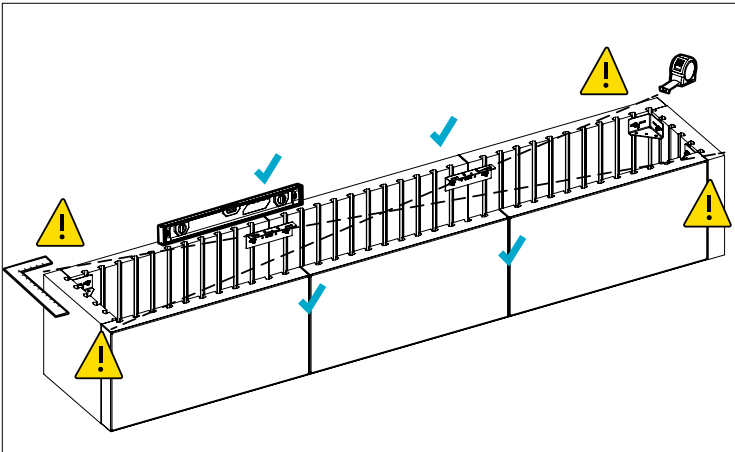

2 GENERAL

Pre-assemble hardware to facilitate its installation. Ensure that all the panels are in place, levelled & aligned before fully tightening the hardware at the end of the installation.

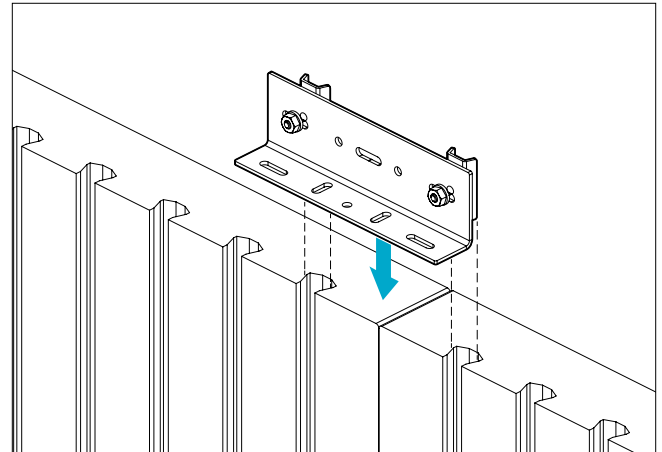

3 ANCHOR SLIDE

Insert anchor slides from the bottom of the closed end panel (panel A) prior to its assembly.

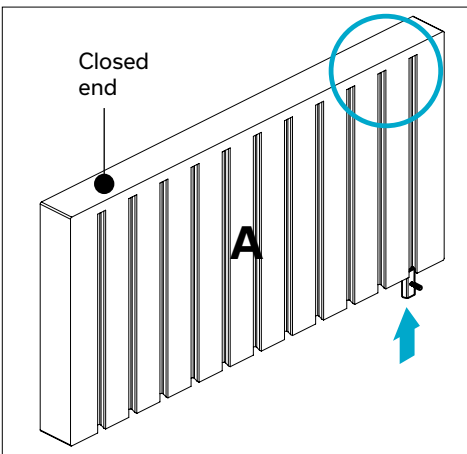

4 ANCHOR SLIDE

Insert the anchor slide. Lock it into place to prevent it from sliding down and to facilitate assembly.

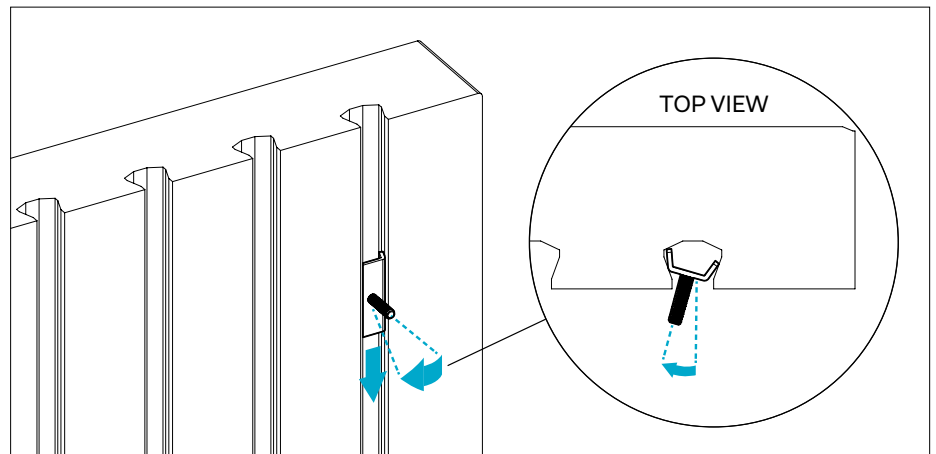

TIPS AND TRICKS - SUITE

5 JOINING PLATE

Use the larger tab of the joining plate when it is perpendicular or parallel to the dovetail slot.

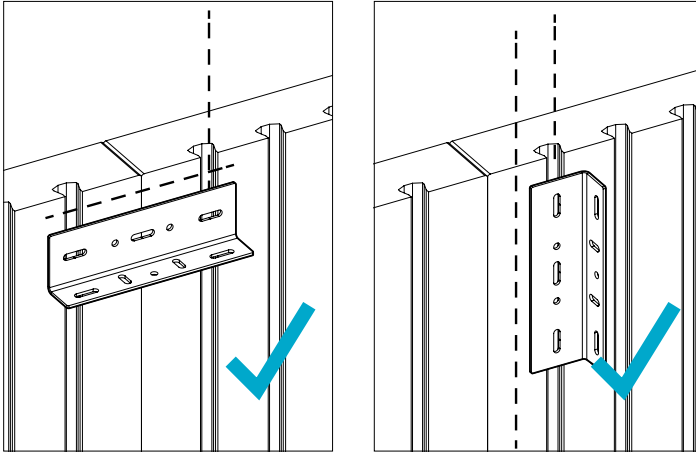

6 JOINING PLATE

Only when the joining plate is perpendicular to the dovetail, the small tab can be used. Otherwise, the overlapping surface will be too narrow.

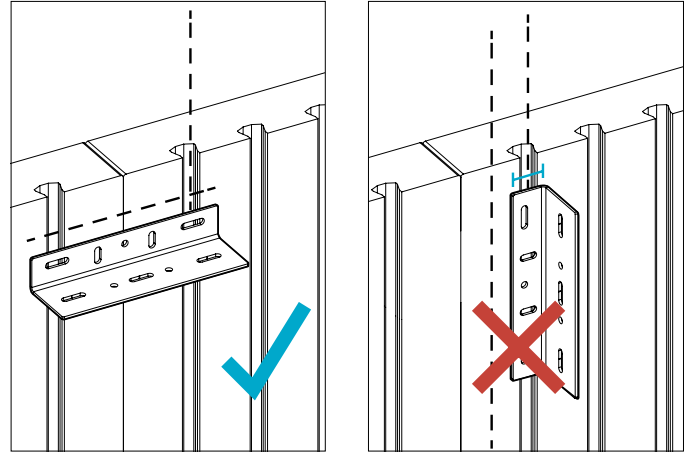

7 STRETCHER BAR

Use the stretcher bar when it is perpendicular to the dovetail. Otherwise, the overlapping surface will be too narrow.

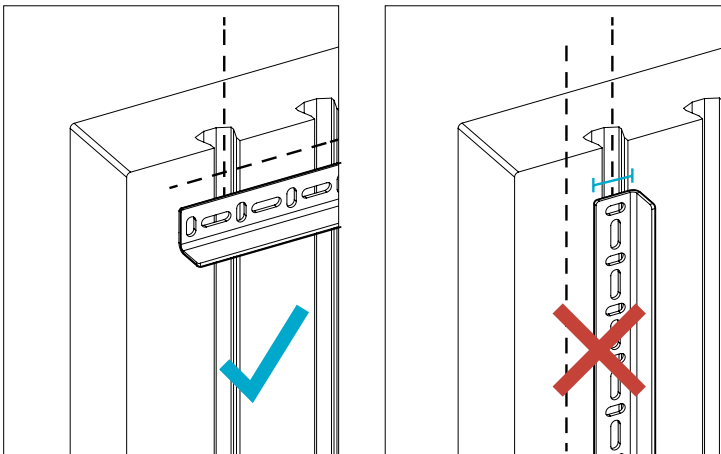

8 CLAMP

Use the bar clamp to keep the panels in place and to facilitate the hardware installation.

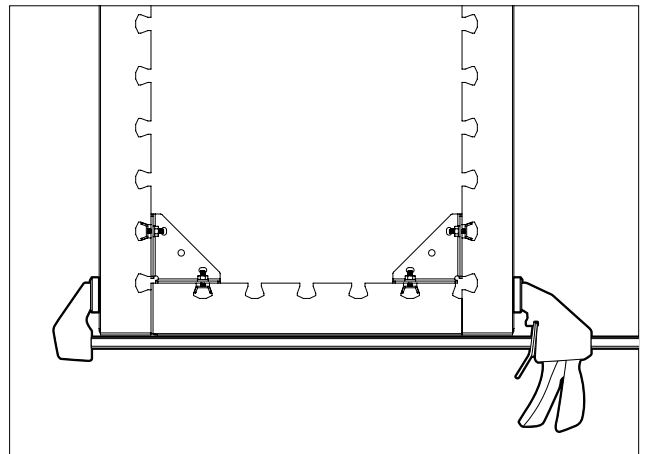

TIPS AND TRICKS - SUITE

9 GENERAL
 If required it is possible to secure the ARTEX structure to the existing base by placing the hardware against it. Contact ex-perts/engineers to validate the structure and any related matters.

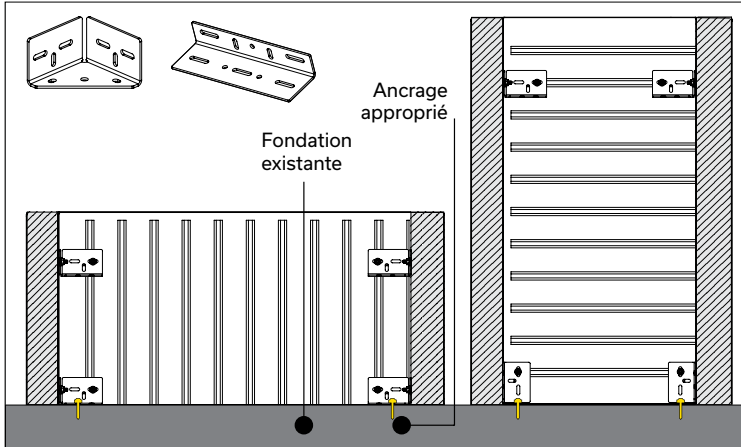

10 GENERAL
 In the case you forgot to place the anchor slides when the closed end panels (panel A) have already been assembled, use a chipping hammer to break a small section of the dovetail slot to insert the anchor slide.

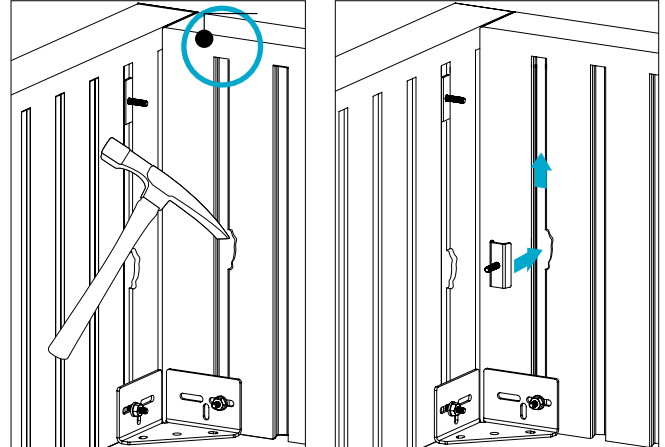

11 GENERAL
 If the side to side panels have a different thickness, use plastic shims to align the front face.

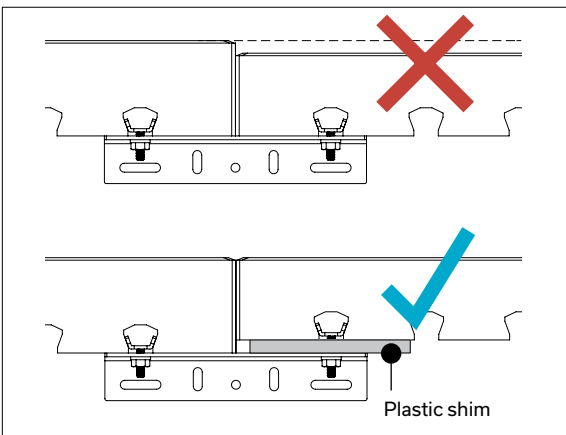

12 GENERAL
 If assembling the hardware on the side of the panel without dovetails, drill the panel and use a concrete screw anchor (Tapcon®).

NOTE: Y - Concrete screw anchor (Tapcon®) 1/4 x 1 3/4 in. or 3/16 x 1 3/4 in.

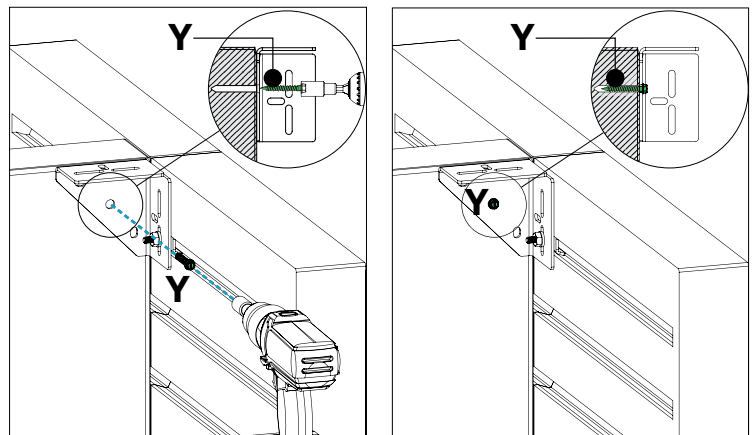

Orion Firepit

DESCRIPTION



Create a cozy atmosphere with the Orion Firepit. With its sleek and elegant look, it will certainly become the gathering spot of your landscape design. This easy-to-assemble product includes the necessary number of concrete units, a black galvanized metal insert, and hardware. The spark arrestor which can be added to the order, is simply inserted in the centre of the firepit.

ASSEMBLY

CONTENT

ORION FIREPIT KIT INCLUDES:

- > 12 Orion concrete units in Range Scandina Grey (12051110) or Range Amber Beige (12051111)
- > 1 black galvanized metal insert including necessary hardware (in a box)

The spark arrestor (205500004) is sold separately.

12 x Orion
concrete units

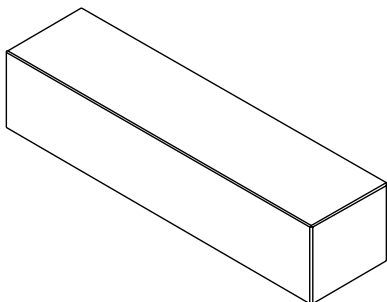

1 x metal
insert box

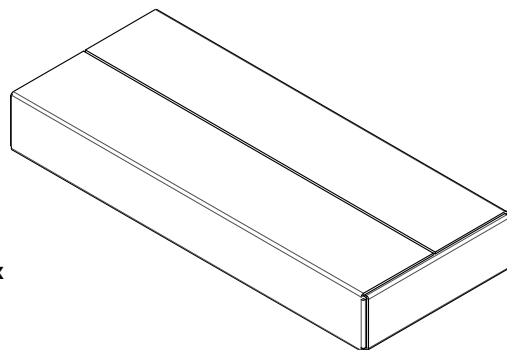

ORION FIREPIT

ASSEMBLY

IN THE BOX:

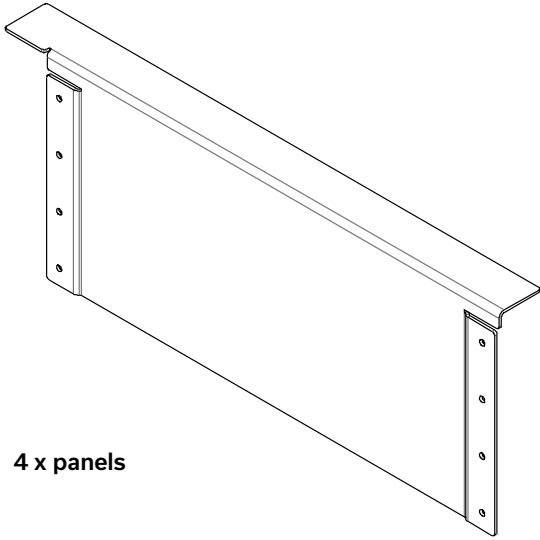

4 x panels

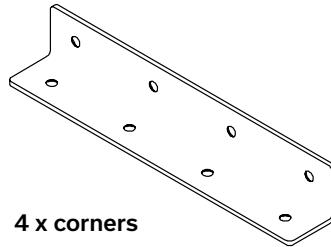

4 x corners

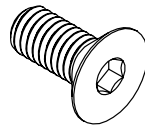

32 x bolts



32 x nuts

SPARK ARRESTOR

IN THE BOX:

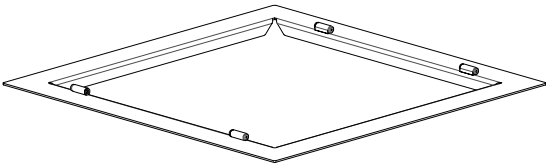

1 x frame

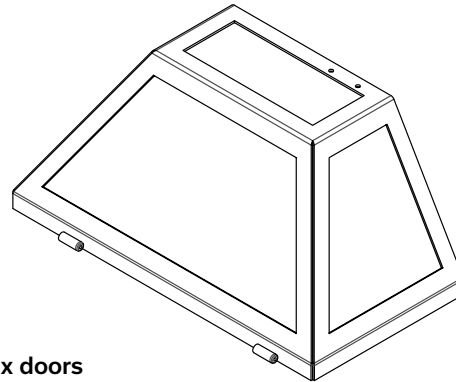

2 x doors

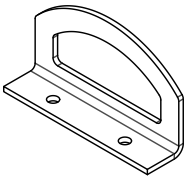

2 x handles



2 x metal rods

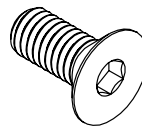

4 x bolts



4 x nuts

ORION FIREPIT INSTALLATION

ORION FIREPIT UNITS

- > Prepare the installation area by referring to the slab installation portion of the Permacon installation guide
- > Ensure the base is level prior to installation
- > Install the Orion concrete units in desired location
 - Install the units on the ground in a square shape. Make sure every unit is used once as a corner
 - Once the first row is complete, apply Techniseal concrete adhesive on top of the units
 - For the second row, offset the corners to avoid vertical joint lines
 - Apply Techniseal concrete adhesive on top of the second row of units
 - For the third row, offset the corners once again so they have the same vertical joints as the first row
- > If the firepit is in an area with slabs or pavers, install them around the firepit and cut where necessary

CAUTION !

Orion units must be turned on their side once removed from the skid. The spacers should face the ground.

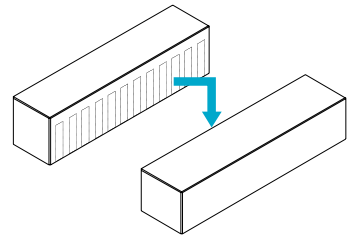

METAL INSERT

All the necessary tools for the following steps, such as a hex key and a flat key, are provided in the nuts-and-bolts bag.

1

Assemble a **corner** to a **panel** using the supplied nuts-and-bolts. The corner goes on the outside of the panel. The bolts should point to the inside of the firepit and the nuts go inside the firepit.

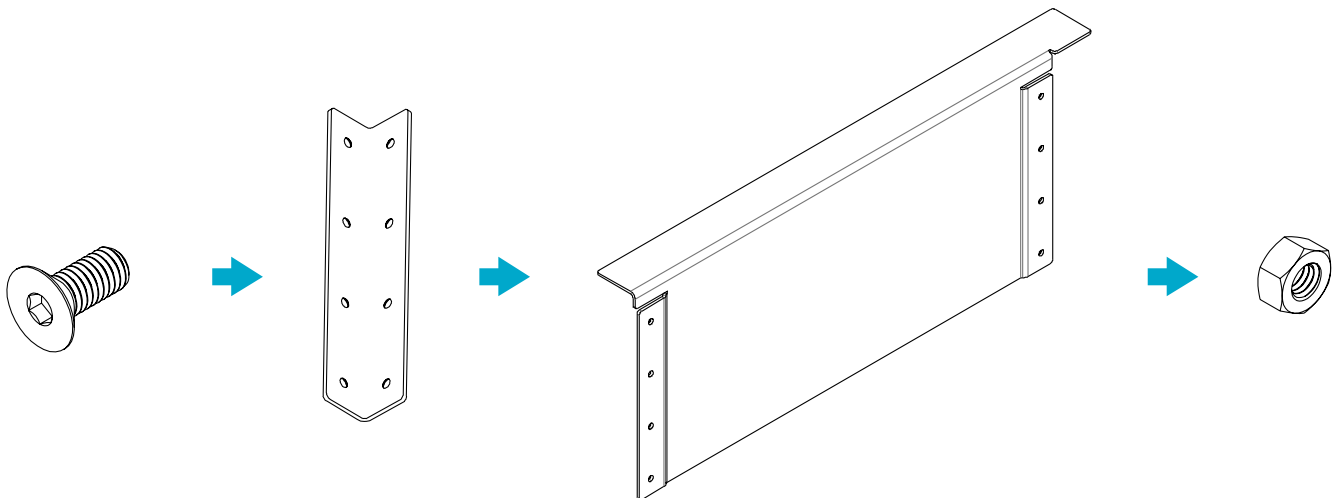

ORION FIREPIT INSTALLATION

2

Repeat step #1 to attach all four panels of the metal insert.

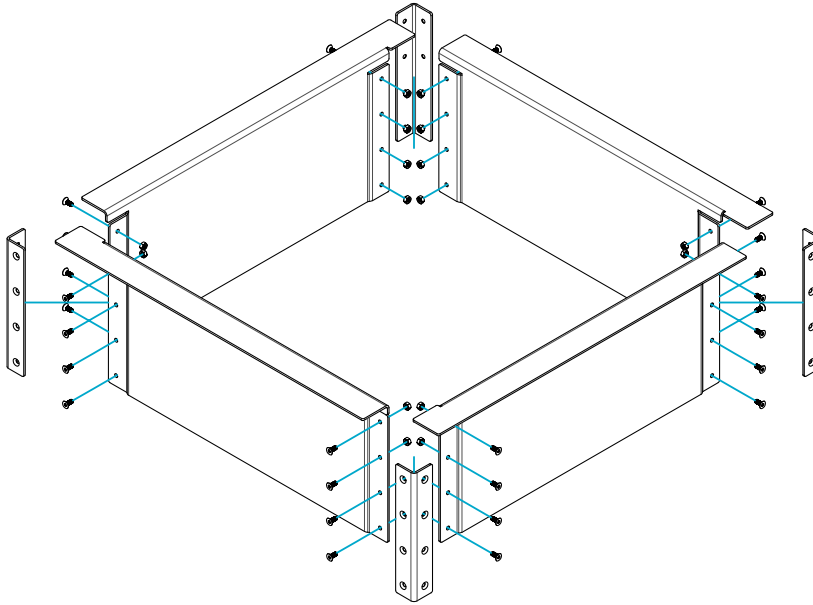

3

Slide the metal insert in between the assembled Orion Firepit. It is not necessary to use concrete adhesive to glue the insert to the Orion Firepit.

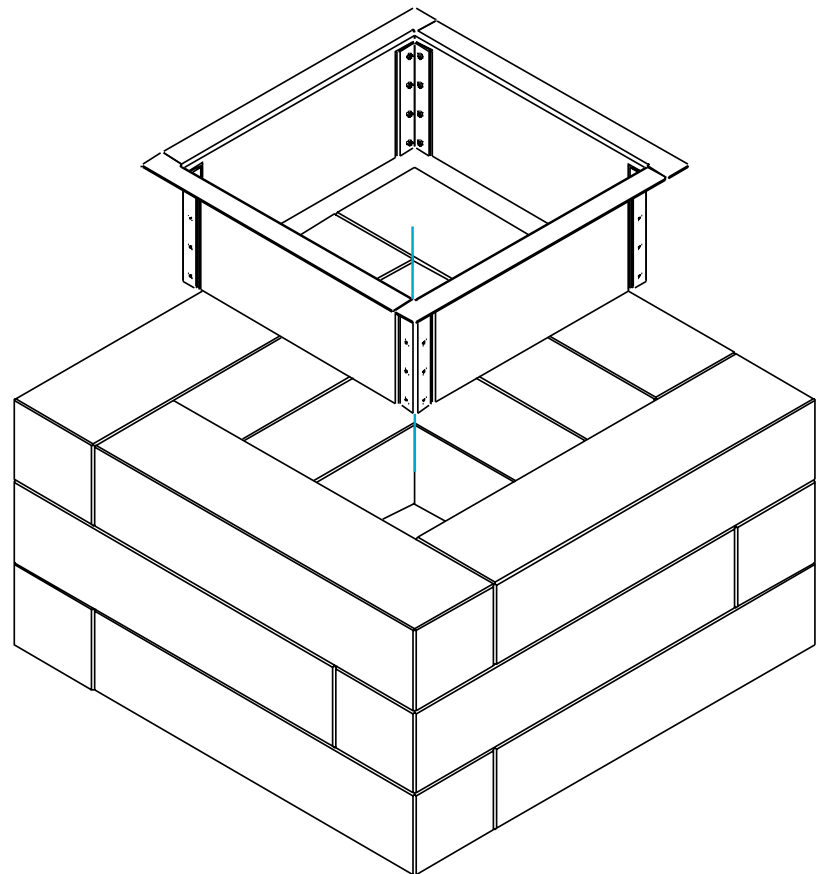

4

Put 3/4 in. net stone at the bottom of the firepit till it meets the edge of the metal insert (depth of the stone: 290 mm or 11 3/8 in.). This step is essential to protect the units against the intense heat of the fire.

SPARK ARRESTOR INSTALLATION

SPARK ARRESTOR

All the necessary tools for the following steps, such as a hex key and a flat key, are provided in the nuts-and-bolts bag.

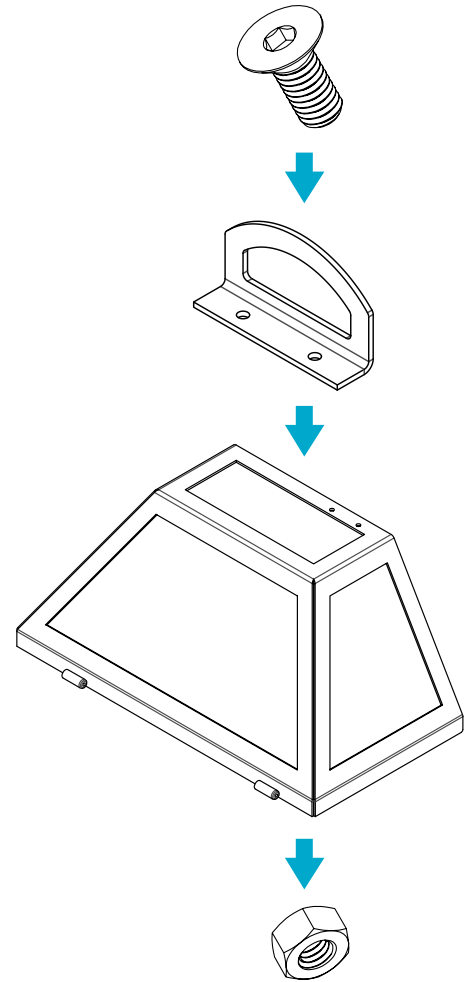
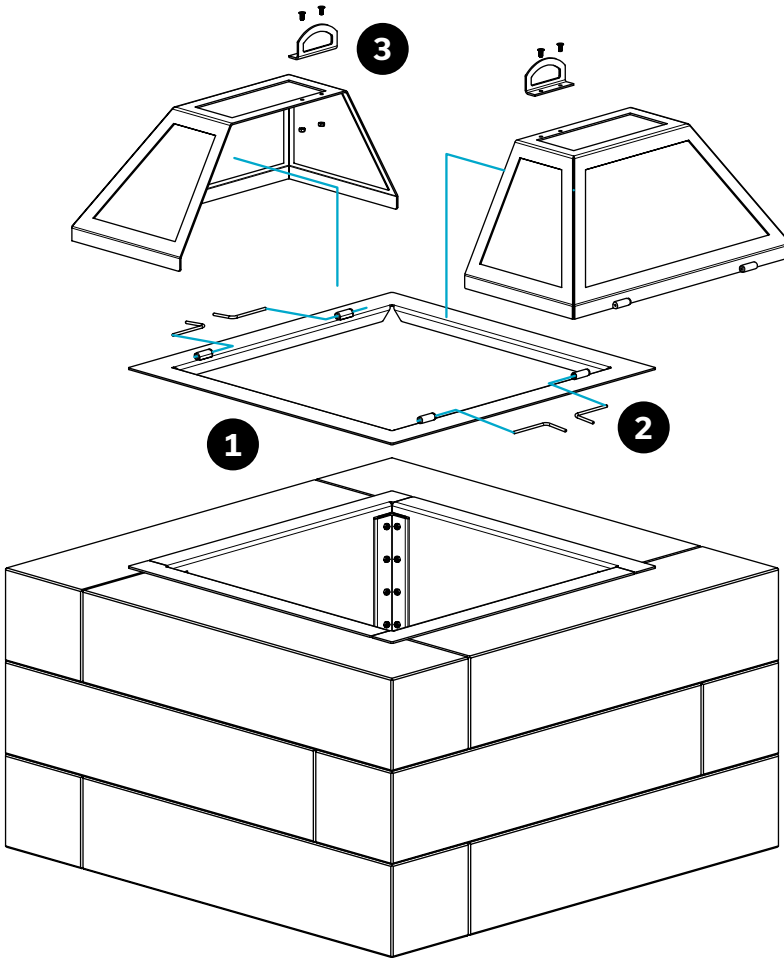

1
Position the **frame** over the Orion Firepit metal insert.

2
Attach the **doors** to the **frame** using the **hinges** and **metal rods**. Align both cylinders of the hinges together and insert the metal rod to complete this step.

3
Screw the **handles** to the **doors** with the supplied nuts-and-bolts. The bolts should point to the inside of the firepit. The nuts go inside the firepit.

ORION FIREPIT AND SPARK ARRESTOR

The Orion Firepit is now assembled. Make sure to follow any municipal by-laws regarding outdoor fires.

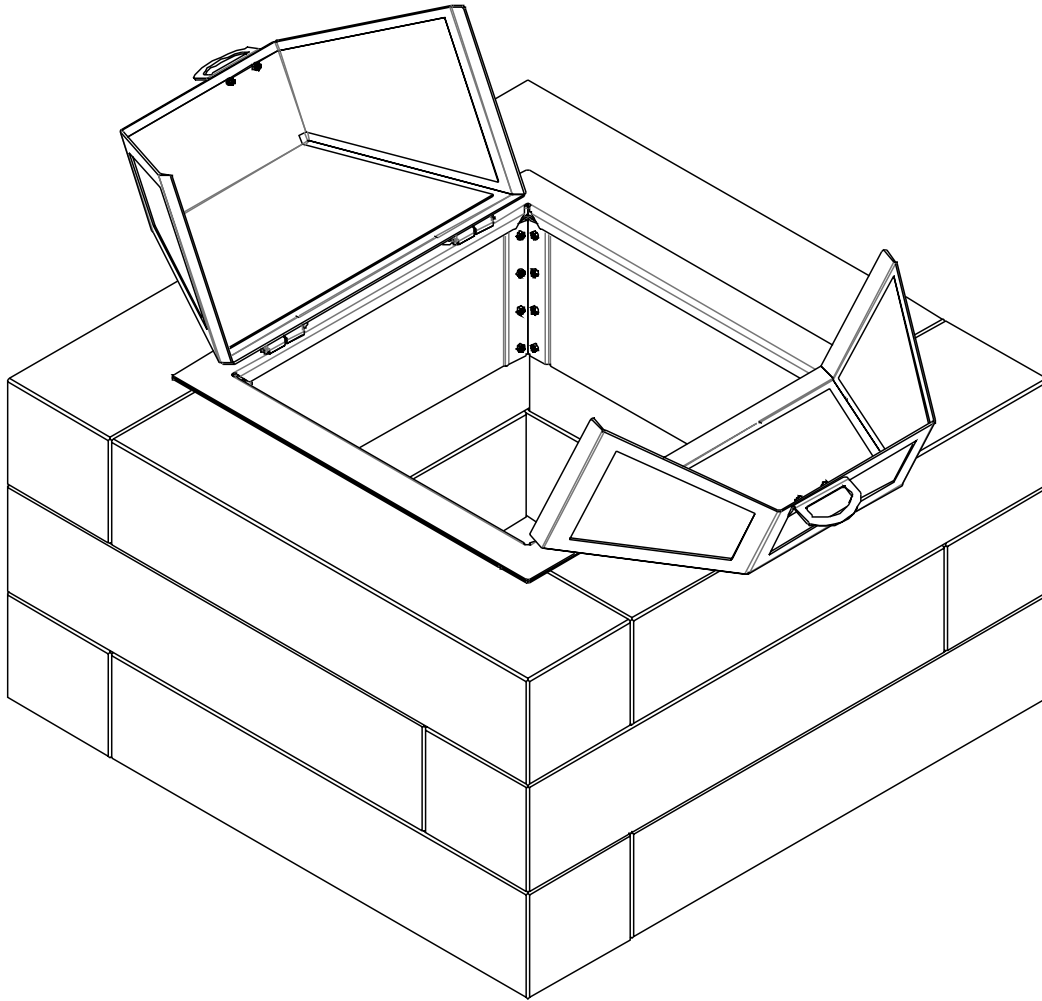

Polymeric Sand



Polymeric SmartSand



Polymeric HP Nextgel Sand



Polymeric RG+ Nextgel Sand



Polymeric Noco Sand

QUANTITY CHART FOR FILLING JOINTS FOR SLABS AND PAVERS SURFACE PER BAG OF 22.7 KG (50 LB)

PAVERS

	Techniseal Polymeric Sands
Brooklyn Paver <i>New</i>	70 ft ² (6.5 m ²)
Capio Paver <i>New</i>	108 ft ² (10.2 m ²)
Cassara Large Rectangle Paver	62 ft ² (5.73 m ²)
Eko Mix Paver	76 ft ² (7.2 m ²)
Eko Small Rectangle Paver	51 ft ² (4.7 m ²)
Eselto DuraFusion Paver	124 ft ² (11.53 m ²)
Kensington Paver	47 ft ² (4.36 m ²)
Kensington Smooth Paver	37 ft ² (3.44 m ²)
Mega Melville Paver	217 ft ² (30.19 m ²)
Melville 60 Small Rectangle Paver	103 ft ² (9.60 m ²)
Melville 80 Paver	116 ft ² (10.79 m ²)
Melville 80 Small Rectangle Paver	77 ft ² (7.20 m ²)
Melville 80 DuraFusion Paver	116 ft ² (10.79 m ²)
Melville Classic Paver	65 ft ² (6.08 m ²)
Melville Plank Paver - Large	79 ft ² (7.32 m ²)
Melville Plank Paver - Slim	54 ft ² (5.06 m ²)
Mondrian Plus 60 Small Rectangle Paver	38 ft ² (3.56 m ²)
Mondrian Plus 80 Paver	43 ft ² (3.99 m ²)
Mondrian Plus 80 Small Rectangle Paver	29 ft ² (2.67 m ²)
Niagara 60 Paver	82 ft ² (7.59 m ²)
Trafalgar 60 Paver	122 ft ² (11.37 m ²)
Vendome 80 Paver	33 ft ² (3.06 m ²)
Vendome 60 Paver	44 ft ² (4.08 m ²)

SLABS

	Techniseal Polymeric Sands
Cassara Large Rectangle Slab	103 ft ² (12.16 m ²)
City Slab	147 ft ² (13.63 m ²)
Eselto DuraFusion Slab	165 ft ² (15.37 m ²)
Mega Melville Slab	289 ft ² (26.92 m ²)
Melville 24 x 24 Slab	248 ft ² (23.04 m ²)
Melville 60 Slab	155 ft ² (14.39 m ²)
Melville 60 DuraFusion Slab	155 ft ² (14.39 m ²)
Metrik Slab	55 ft ² (5.10 m ²)
Mondrian Plus 50 Slab	186 ft ² (17.26 m ²)
Mondrian Plus 60 Slab	57 ft ² (5.31 m ²)
Rosebel Slab	75 ft ² (6.36 m ²)
Wilfrid Slab	244 ft ² (22.68 m ²)
Vertex Slab <i>New</i>	181 ft ² (16.84 m ²)

QUANTITY CHART FOR FILLING JOINTS FOR ARCHITECTURAL PAVERS

Description			Surface Area	
Paver	Thickness (mm)		ft ² / bag of 22.7 kg	m ² / bag of 22.7 kg
Boulevard TLI-200 mm	(multi-length)	200	46	4.3
Boulevard TLI-150 mm	UNITS			
	500 mm x 750 mm	150	93	8.6
	500 mm x 500 mm	150	77	7.2
	500 mm x 250 mm	150	52	4.8
	500 mm x 125 mm	150	31	2.8
Boulevard TLI 150 Crescendo 320	(multi-length)	150	47	4.4
Boulevard TLI-150 mm	200 mm x 200 mm	150	27	2.5
Boulevard TLI 150 Crescendo 125	(multi-length)	150	28	2.6
Boulevard TLI-100 mm	UNITS			
	300 mm x 300 mm	100	91	8.5
	150 mm x 300 mm	100	60	5.5
Boulevard TLI 100 Crescendo 300	(multi-length)	100	120	11.2
Boulevard TLI-100 mm	300 mm x 700 mm	100	172	16.0
Boulevard TLI 90 Crescendo 320	(multi-length)	90	70	6.6
Boulevard TLI-90 mm	160 mm x 240 mm	90	40	3.7
Boulevard TLI-90 mm	320 mm x 520 mm	90	83	7.7
Boulevard TLI-80 mm	120 mm x 240 mm	80	49	4.5
Boulevard 300	UNITS			
	600 mm x 600 mm	100	78	7.3
	200 mm x 600 mm	100	34	3.1
	300 mm x 600 mm	100	52	4.9
	300 mm x 300 mm	100	39	3.7
	150 mm x 150 mm	100	20	1.9
	150 mm x 300 mm	100	27	2.6
	150 mm x 450 mm	100	29	3.6
	100 mm x 300 mm	100	24	2.2
	100 mm x 450 mm	100	22	2.0
	100 mm x 600 mm	100	41	3.8
	Boulevard 500	500 mm x 500 mm	100	66
Agora 80	300 mm x variable	80	53	4.9
Agora 100	300 mm x variable	100	70	6.6
Paleo-Tec	140 mm x 220 mm	80	41	3.8
Vertex	100 x 150 mm and 300 x 600 mm	100	79	7.3

All **the tools** you need to design your project



VISUALIZATION TOOL

Create, dare, change, start again...
in complete freedom!



MAINTENANCE

Protect your investment



INSPIRATION

Let yourself be inspired by
our gallery of projects



permacon.ca

PERMACON

50-Year Warranty

Residential Landscape and Masonry



Permacon's 50-year warranty applies to landscape and masonry products including Suretouch intended for residential use¹. This warranty statement affirms that products manufactured by Permacon meet the requirements of CSA (Canadian Standard Association) and ASTM (American Society for Testing and Materials) standards.

For details regarding commercial applications, please refer to our institutional, commercial and industrial warranty.

Permacon guarantees that, as of the date of delivery, its concrete products are free from manufacturing defects. Provided that the conditions set forth below are met, Permacon guarantees the structural integrity of the concrete in its landscaping and masonry products for a period of 50 years from the date of the product's purchase. The warranty applies to normal, non-abusive use of the product. To preserve the original appearance of your products, we recommend that you consult our **Landscape Maintenance Guide** available on our website.

IN ALL CASES DETAILED BELOW, THE WARRANTY IS LIMITED TO THE PRODUCTS' MARKET VALUE.

How do I make a claim?



permacon.ca/en/warranty/



Proof of purchase is required to proceed with a claim request. No claims will be accepted without proof of purchase.²

All claims must be reported within 15 days of the discovery of a product's defect. To validate a claim, a Permacon representative will arrive to inspect the defective products in order to confirm whether the claim is eligible. Therefore, it is essential to provide Permacon with the necessary access to inspect and take photos of the affected products.

This warranty is the only one that is presently offered. Because Permacon continually improves and modifies its products, it may alter and discontinue products at any time, and therefore may replace warranty-covered products with products of similar quality or offer monetary compensation if the products under warranty have been discontinued or are no longer on the market while the warranty is active.

In the event that a product is found to be non-compliant by Permacon or an authorized representative of the company, and in order to proceed with compensation, Permacon will take into account the number of months during which the

landscape or masonry products were in the possession of the owner or their contractor, up to the date of the claim, and will prorate the amount of the payment or replacement to be made accordingly.

For example, if the purchaser makes a warranty claim in the last month of the 10th year of the warranty (i.e., the 120th month), the manufacturer, at its sole discretion, shall either:

- Provide a replacement for the product in question if still available (only the defective product will be replaced);
- Return 480/600 of the price paid for the products to the owner. No labour, transportation, or other compensation will be covered by Permacon.

Transferability

The warranty is transferable. Proof of warranty registration will still be required in the event of a claim. The prorated period will be based on the 50-year warranty period remaining as an assignee, if the purchaser transfers the warranty to a subsequent owner, as described above.

¹ The following locations are defined as residential: family dwelling of five units or less, single family homes, garden suites, or townhouses.

² The following documents are considered valid proof of purchase: invoices directly from an authorized Permacon distributor, or invoice from a landscape contractor, general contractor, mason, or home builder.

Exclusions

A landscape or masonry product installed on an area of more than **100 square feet** confirms the acceptance of the product received on the job site and that no claim can be made to Permacon regarding the colour, size, or texture of the product.

This warranty excludes all products not supplied by Permacon, as well as any defects, failures, or damages that may result from the actions listed below:

- Contact with chemicals or cleaning products;
- Damage caused by pressure washers;
- Improper installation or other construction activities that do not comply with the installation standards established by ICPI, NCMA or IMQ, the National Building Code or the installation methods and tips recommended by Permacon. The installation guides provided by Permacon represent certain installation situations and are not exhaustive. It is therefore strongly recommended that you consult a qualified professional to ensure the proper installation of Permacon products on a specific job site;
- Defective design or construction resulting in sagging, shifting, or failure;
- Breakage due to shock, impact, or excessive load during handling, use, or transportation;
- Natural disaster or other uncontrollable event;
- Breakage and damage to products caused by soil movement or building movement as well as misuse of construction, compaction, or snow removal equipment. The warranty does not cover surface deterioration caused by the misuse of sodium chloride (NaCl) to de-ice pavers, slabs, or steps;
- The use of sodium chloride (NaCl) on the following products:
 - Step Valentia;
 - Valentia Block;
- Be.OnStone and Mirage products sold by Permacon.

Installation

When installing masonry products, all work must be cleaned to remove any residues and contaminants left on the stone or brick. Permacon accepts no responsibility for stains and colour changes caused by installation residue or the consequences of cleaning these residues.

Colour

The presence of natural ingredients used in the manufacturing process varies from one product to another. Therefore, the product received on the job site will not be completely identical to the products displayed in our commercial presentations (catalogs, samples, displays). Any difference in colour will not be covered by the guarantee.

Photos of our products in landscape and masonry brochures, as well as in displays such as masonry panels and landscape racks at our distributors, are not an exact representation of the products that will be delivered to the job site. Permacon offers a variety of products with different colours to reproduce the appearance of natural stone. It is therefore strongly recommended that you view several products directly from your authorized Permacon distributor to see all available colours.

It is the purchaser's responsibility to approve the products (and their colour) delivered to the job site prior to installation to confirm satisfaction. It is also recommended to mix products from different pallets received on the job site. Since variations in colour shades are a natural phenomenon, Permacon does not guarantee colour uniformity between different pallets on the same job site. Product installation constitutes acceptance.

Polymeric film

A whitish polymeric film can be found on the surface of Permacon's products. This is the result of an inadequate use of polymeric sand. Improper cleaning of slabs and pavers prior to the application of water on the product surface can cause this whitish polymeric film. This film does not affect the structural integrity of the product. Permacon cannot be held responsible for this phenomenon, which is not covered by the warranty.

Efflorescence

White traces on the surface of the product are caused by a natural phenomenon called efflorescence. More visible on darker products, efflorescence affects neither the intrinsic technical qualities nor the structural integrity of Permacon's products. The possible appearance of efflorescence cannot be the subject of any guarantee. In most cases, efflorescence disappears by itself over time.

Our Preventive Maintenance Guide for Concrete Landscaping Products is available on our website permacon.ca

For more information on our institutional commercial and industrial warranty, please visit <https://permacon.ca/en/warranty/>



Revised 2024

1 888 PERMACON
PERMACON.CA



PERMACON
A CRH COMPANY