

# Mirage Porcelain Tiles

## CROSS-SECTION - CONCRETE BASE INSTALLATION

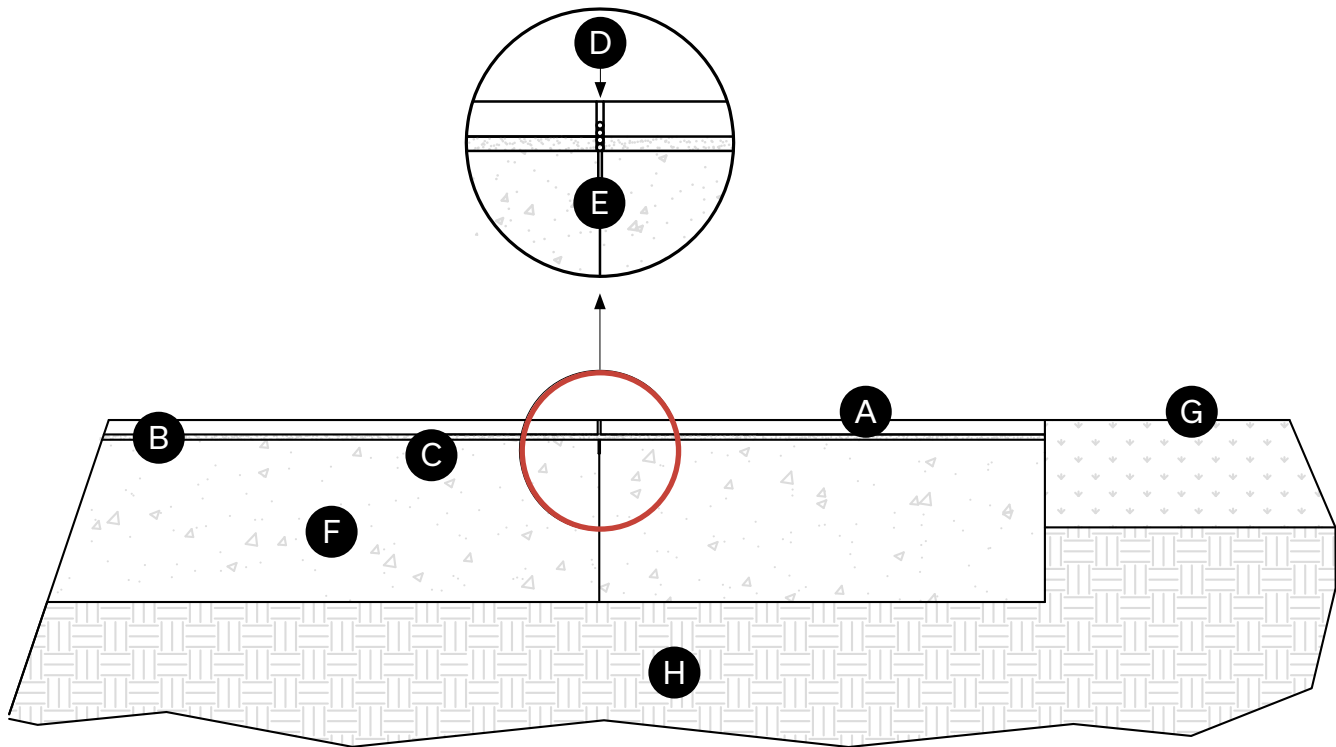

- Ⓐ Mirage porcelain tile (20 mm thickness)
- Ⓑ Joint grout for porcelain tile - 8 to 10 mm width (Ultracolor Plus or Keracolor S from Mapei or equivalent)
- Ⓒ Cementitious adhesive for porcelain tile (Kerabond T/Keralastic or Ultraflex LFT from Sika)
- Ⓓ Contraction/Control joint (architectural urethane sealant and sealant backer rod)
- Ⓔ Saw cut contraction joint. The depth of the saw cut must be a minimum of 1/4 of the thickness of the concrete slab (to induce crack beneath saw cut contraction joint).
- Ⓕ Structural concrete base 150 mm minimum thickness (design by others)
- Ⓖ Grass
- Ⓗ Existing soil with adequate bearing capacity (minimum of 100 kN/m<sup>2</sup>)

NOTES: The concrete slab must have a contraction/control joint (every 5 lin. m max). It is absolutely imperative that all contraction/control joints be located in the joint line of the installed porcelain tile and not beneath the tile. The concrete slab must be cured at least 28 days before the installation of any porcelain tiles.

Never compact porcelain tile with a plate compactor. Insure the pavement is constructed with a 2 degree slope and that it is pitched away from any building.

This installation is dedicated to a pedestrian application only. The actual structural design for light vehicular application must be performed by a qualified professional Engineer.

**GENERAL NOTE: THE MIRAGE PORCELAIN TILES CAN BE CUT BY USING A TABLE WATER SAW WITH A DIAMOND BLADE SPECIALLY DESIGNED FOR PORCELAIN.**

**CROSS-SECTION - GRANULAR BASE INSTALLATION**

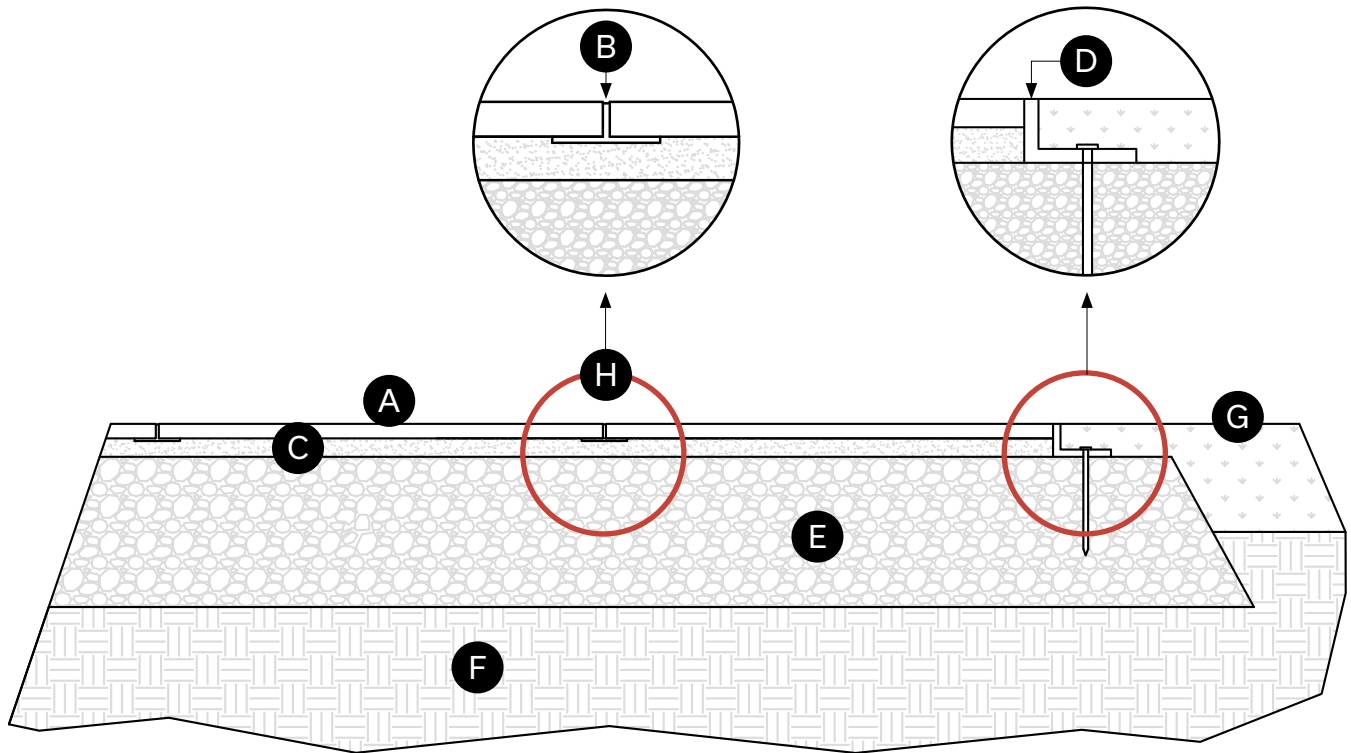

- Ⓐ Mirage porcelain tile (20 mm thickness)
- Ⓑ Joint grout for porcelain tile - 8 to 10 mm width (Ultracolor Plus or Keracolor S from Mapei or equivalent)
- Ⓒ Bedding sand 25 mm max: concrete sand (0-5 mm). Pre-compact the sand bedding course and screed to a 12 mm thickness with smooth surface
- Ⓓ Peripheral restraint system spiked into 150 to 200 mm over base area. Base material is to be over based 150 to 200 mm beyond the edge of the pavement.
- Ⓔ Crushed stone 200 to 300 mm - 0 to 20 mm compacted to 95% modified proctor
- Ⓕ Existing soil with adequate bearing capacity (minimum of 100 kN/m<sup>2</sup>)
- Ⓖ Grass
- Ⓗ Plastic spacers for Mirage porcelain tiles to insure 4 mm between tiles. 1 spacer is required at every corner.

NOTES: Never compact porcelain tile with a plate compactor. Insure the pavement is constructed with a 2 degree slope and that it is pitched away from any building.

This installation is dedicated to a pedestrian application only. The actual structural design for light vehicular application must be performed by a qualified professional Engineer.

**General note: The Mirage porcelain tiles can be cut by using a table water saw with a diamond blade specially designed for porcelain.**

# MIRAGE PROCELAIN TILES

## UNITS

### QUARZITI 2.0 LARGE RECTANGLE

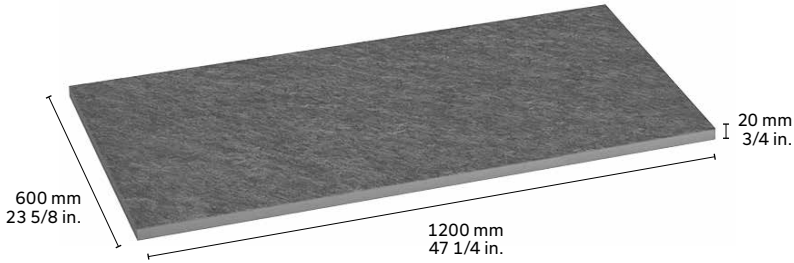

### QUARZITI 2.0 LARGE SQUARE

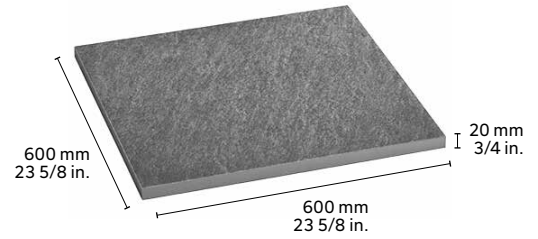

### NOON

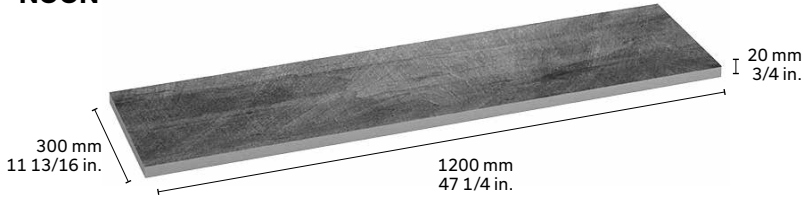

### QUARZITI 2.0 POOL CAPPING

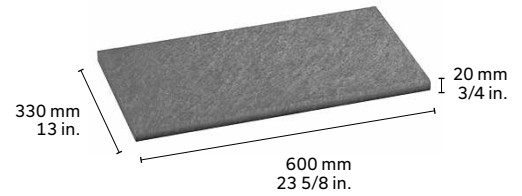

## INSTALLATION ON PEDESTALS

### POSITION OF THE PEDESTALS ACCORDING TO THE SIZE OF THE PORCELAIN TILES

#### 4 PEDESTALS PER UNIT

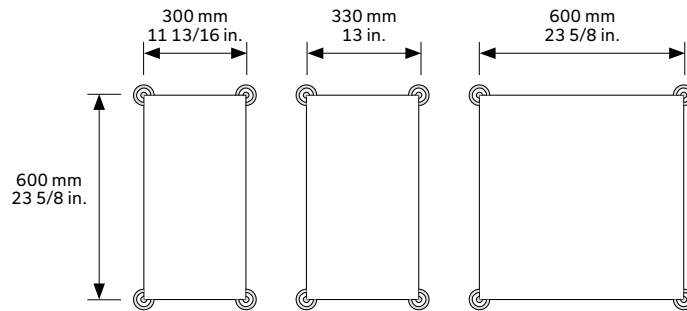

The porcelain tiles installed on a pedestal must have a galvanized steel sheet on the back.

#### 6 PEDESTALS PER UNIT

